



USER MANUAL

OFF-ROAD CRAWLER

NO.EX86150



ROCK CRAWLER



WARNING:
This product is only for 14 years old or above

Notes:

- ⇒ Read and understand the instructions carefully before operating or assembling your racing model.
- ⇒ Specifications are subject to change without prior notice, and actual received model may vary from the images and/or descriptions in this manual.

Remote control models are specialized and high-value products. If you identify any quality defects upon receipt, please do not use the product and contact the seller immediately to arrange a replacement or return. Please note that we cannot provide any after-sales guarantee for damages which are caused by improper use.

The product conforms to technical requirements of export safety regulations.



Please read and follow all the instructions in the manual before use.



MADE IN CHINA

Factory Address: Dong Guan City, Guang Dong Province, China

Production Date: refer to packing instruction

Introduction

We would like to welcome you to the world of remote control cars. What are RC cars? The simple answer is that they are radio controlled cars that respond precisely to your command. The more complete answer is that they can be a great addition to your lifestyle. RC car building and racing teach valuable mechanical and electrical skills, promote teamwork and encourage racers to test their skills with other racers from around the world. Whether you are just having fun racing your car in your backyard or racing at the world competition contest, radio controlled car racing is a great hobby.

We have been making RC products aimed at making our hobby fun and exciting with an affordable price. We are confident that your experience with our products will be positive. Of all the radio controlled models out there, no question about it, RC cars are the hardest to operate. This user manual covers a wide range of topics from nitro powered remote control cars to electrical powered remote control cars. We highly recommend that you read this user manual thoroughly and carefully before assembling and operating. Please follow all precautions and recommendations located within the manual. Be sure to retain the manual for future reference, routine maintenance, and tuning.



This product is not a toy. It is not recommended for children under 14 years old and any minor should be accompanied by an adult when operating. This product is a precision machine that requires proper assembly and setup to avoid accidents. Failure to take caution when operating this product may result in serious injury or property damage. It is the owner's responsibility to operate this product in a safe manner. Manufacturer and its distributors are not responsible in any way for any and all bodily injury(s) and/or property damage that may occur from the use of or caused by in any way or this product.



Warnings

- The product is not intended for those under 14 years of age without proper adult supervision. The product is not a toy. It is a precision machine requiring proper assembly and setup to avoid accidents and it is the responsibility of the owner to operate this product in a safe manner as it can cause serious personal injury and damage to property due to carelessness or misuse.
- Do not attempt to disassemble or modify any of the product components without the assistance of an experienced RC user.
- Only use the correct type of battery to operate. Using any wrong type of battery will damage the product and possibly make it dangerous to operate.
- The motor(s) may get hot during use. Always allow 10-15 minutes between each operation for the motor to cool down. This will prolong the life of your product.
- Choose an appropriate operating site consisting of flat, smooth ground, and clear open field. Do not operate near buildings, high voltage cable lines, or trees to ensure safety operation. Operate in safe area only, away from other people. RC models are prone to accidents, failures, and crashes due to a variety of reasons including, lack of maintenance, user error, and radio interference. Users are responsible for their actions and damage or injury occurring during the operation.
- Do not operate in inclement weather, such as rain, wind, snow or darkness.
- The product is composed of precision electrical components. It is critical to keep the product away from moisture and other contaminants. Do not allow them to get wet. Electrical damage may occur that could affect safe operation.
- You should complete a successful pre-run check of your radio equipment and model prior to each run.
- Use replacement parts from the original manufacturer to ensure safe operation.
- Operate this product within your ability. Do not operate under tired condition
- After each use, always allow the battery to cool down before recharging. When charging the battery pack, do not overcharge! If batteries get hot during charging, discontinue charging immediately and disconnect the battery from the charger. Never leave battery unattended while charging. If you are unsure of how to charge this battery, please seek the advice of experienced RC users. Never let children charge the battery without adult supervision.
- Always turn on the transmitter before connecting the battery on the model. When turning off the model, always disconnect the battery first, and then turn off the transmitter. If the order is reversed, the model may become uncontrollable and cause serious damage.
- If you are in doubt of your ability to operate the model, we strongly recommend that you seek assistance from experienced RC users or join your local modeling club to gain the required knowledge and skill. As the manufacturer and distributor, we assume no liability for the use of this product.
- Before turning on your model and transmitter, please check to make sure no one else is operating under the same frequency. Frequency interference can cause your model, or other's models to crash. The guidance provided by experienced RC users will be valuable for the assembly, tuning, trimming, and actual first flight.
- Never allow batteries to run low or you might lose control of the model.
- Plastic is very susceptible to damage or deformation due to extreme heat and cold climate. Do not store the model near any source of heat such as oven or heater. Store the model indoors, in a climate-controlled, room temperature environment.
- Never shorten the receiver antenna; or this might affect the transmitting range of the radio system.
- This product is a RC hobby model, do not use for other purpose.

Safety

Pay close attention to the following symbols and their meanings. Failure to follow these warnings could cause damage, injury or death.

 Danger	Not following these instructions may lead to serious injuries or death.
 Warning	Not following these instructions may lead to major injuries.
 Attention	Not following these instructions may lead to minor injuries.

 Prohibited	<ul style="list-style-type: none"> ■ Do not use the product at night or in bad weather like rain or thunderstorm. It can cause erratic operation or loss of control. ■ Do not use the product when visibility is limited. ■ Do not use the product on rain or snow days. Any exposure to moisture (water or snow) may cause erratic operation or loss of control. ■ Interference may cause loss of control. To ensure the safety of you and others, do not operate in the following places: <ul style="list-style-type: none"> ● Near any site where other radio control activity may occur ● Near power lines or communication broadcasting antennas ● Near people or roads ● On any body of water when passenger boats are present ■ Do not use this product when you are tired, uncomfortable, or under the influence of alcohol or drugs. Doing so may cause serious injury to yourself or others. ■ The 2.4GHz radio band is limited to line of sight. Always keep your model in sight as a large object can block the RF signal and lead to loss of control. ■ Do not touch any part of the model that may generate heat during operation, or immediately after use. The engine, motor or speed control, may be very hot and can cause serious burns.
 Mandatory	<ul style="list-style-type: none"> ■ Misuse of this product may lead to serious injury or death. To ensure the safety of you and your equipment, read this manual and follow the instructions. ■ Make sure the product is properly installed in your model. Failure to do so may result in serious injury. ■ Make sure to disconnect the receiver battery before turning of the transmitter. Failure to do so may lead to unintended operation and cause an accident. ■ Ensure that all motors operate in the correct direction. If not, adjust the direction first. ■ Make sure the model stays within the systems maximum range to prevent loss of control.

Thanks for purchasing our RC car. The power system for RC model can be very dangerous, so please read this manual carefully. In that we have no control over the correct use, installation, application, or maintenance of our products, no liability shall be assumed nor accepted for any damages, losses or costs resulting from the use of the product. Any claims arising from the operating, failure of malfunctioning etc. will be denied. We assume no liability for personal injury, consequential damages resulting from our product or our workmanship.



START GUIDE

1. Please read the manual carefully and prepare the following things before use.

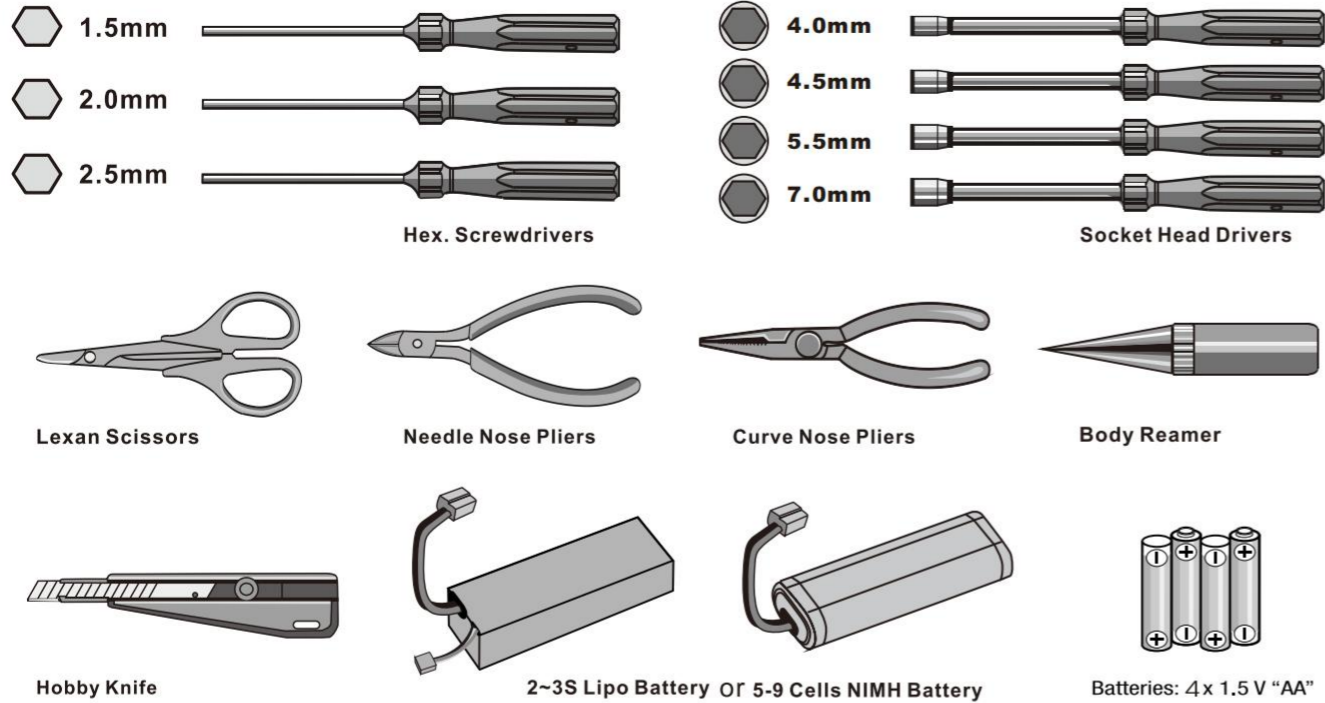

2. The items inside the box.

One car



3. Please check the whole product condition when open the package.

- 3-1. After each day of running, you should check your shocks for adequate fluid. If the fluid is low, or it is getting dirty, you should change the fluid in the shocks. To achieve better performance, you may also want to change the shock fluid and or the pistons.
- 3-2. Gear mesh is the clearance between the pinion and spur in an electric car or clutch bell and spur in a nitro car. It has impact on the vehicles performance. If the gear mesh is not set properly you may also damage the clutch bell and spur or the pinion gear and spur gear as soon as the vehicle starts running.
- 3-3. Please check if the screw is tight enough before use. Screw it tight (or apply the screw glue if necessary)
- 3-4. Regularly check and verify the tires are intact. No breach should be observed. Please apply the CA glue if needed.

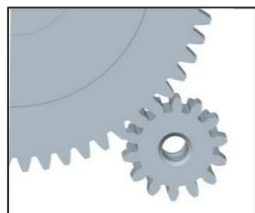

4-1. Install Charged Batteries In Car.

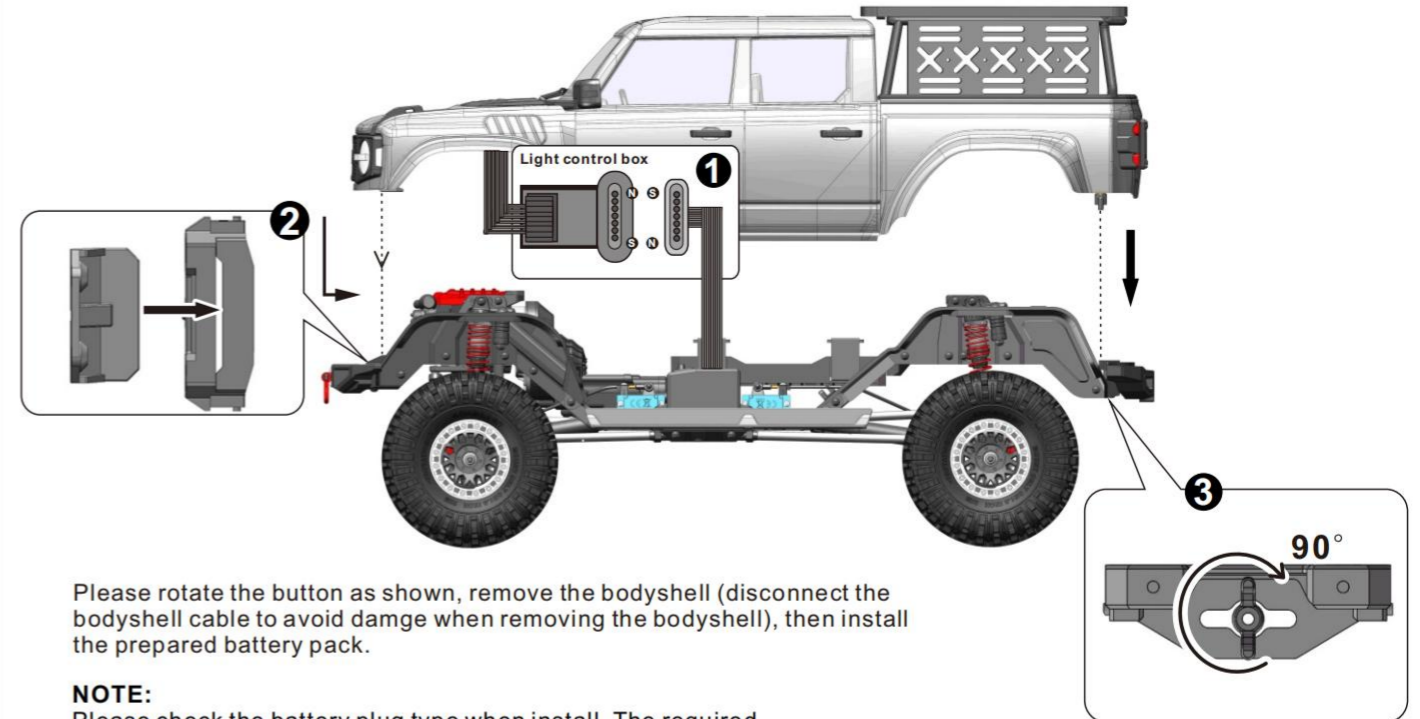

4-2. Scheme of installation

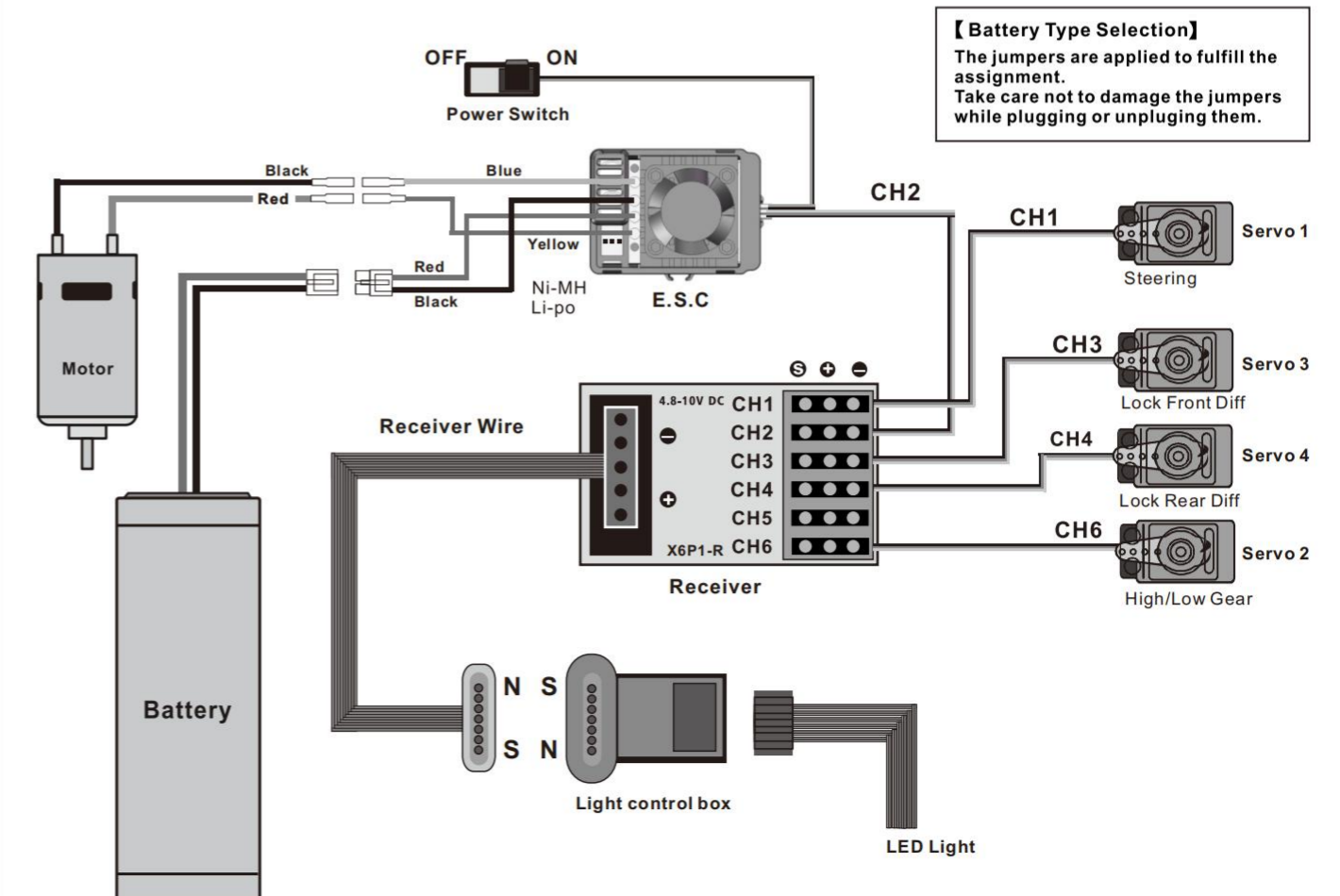

4-3. Battery Specifications for Product

WARNING:
NO battery includes in factory. Recommend battery: 2S~3S LIPO battery or 5-9 cells NIMH battery (please match the ESC mode with the corresponding battery type) Pay attention to the battery size and plug specification when purchasing. The maximum battery measurement is 142*48*55mm JLxWxH).

This product can use the 2S or 3S Li-Po battery.

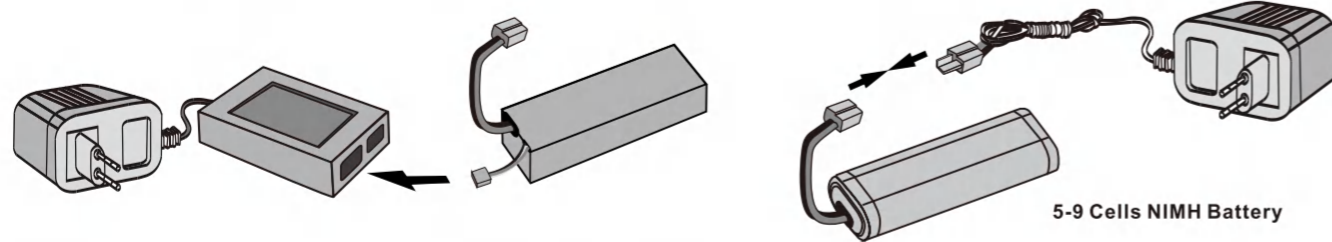

NOTICE
Please check the battery voltage before use. Please use a qualified charger to charge the newly purchased battery. (please read the charging steps in manual when necessary)

Charge the vehicle battery

- Connect charger plug with mains jack and then connect with connector of battery.
- Please be care of safety while charging, please remove charger plug from the mains jack once finish charging. Will be over heat if it is too long to be charging or incorrect charging way. must stop charging if over 45 degree for the battery temperature.
- Do not charge for battery at once when you take it away from your car. Please make sure battery in cool condition before recharge battery to keep battery performance running well and get a longer use life.

NiMH Battery Instructions

- Never dispose of NiMH batteries in a fire or store near sources of heat.
- Only use the supplied NiMH charger to charge the NiMH battery. Using another charger may permanently damage the battery and surrounding components and may also lead to injury.
- Batteries should only be charged on a fireproof surface, away from any flam-mable materials.
- Never leave the battery unattended when charging or discharging.
- Batteries must be discharged or fully exhausted before being disposed of. Cover exposed poles with adhesive tape to prevent short-circuiting!
- Never disassemble or alter the battery contacts. Do not damage or puncture battery cells. Doing so would result in an explosion hazard!
- Keep the NiMH battery away from children.

Lithium Polymer (LiPo) Battery Warnings

- Never charge a lithium polymer battery with a charger designed for NiCd, NiMH, or any other type of battery chemistry. Use ONLY charger designed for LiPo battery.
- Do not leave LiPo battery unattended during charging.
- Do not overcharge the battery.
- Always place the battery on a heat resistant surface alone when charging.
- Always put the LiPo battery inside a charging protection coatner while charging.
- Do not allow LiPo cells to overheat at any time. Cells which reach greater than 140 Fahrenheit (60C) will usually become damaged and will catch fire.
- Do not charge LiPo cells on or near combustible materials including paper, plastic, carpets, vinyl, leather, and wood inside an R/C modl or full size automobile.
- Do not discharge LiPo; doing so will damage the battery.
- Do not expose LiPo cell to water or moisture at any time.
- Do not store battery near open flame or heater.
- Do not assemble LiPo cells or pre-assembled packs together with other LiPo cells or packs.
- Always store LiPo battery in a secure location away from children.
- Always remove the LiPo battery if model is involved in any kind of crash. Carefully inspect the battery and connectors for even the smallest damage. CAUTION: cells may be hot!
- Do not allow the electrolyte to get into eyes or on skin. Wash affected areas immediately if they come into contact with electrolyte. Do not alter or modify connectors or wires of a LiPo battery pack.
- Always inspect the condition of the battery before charging and operating.
- Do not short circuit the LiPo battery.
- Do not have contact with a leaky/damaged battery directly.
- Do not charge battery out of recommended temperature range (0C - 45C).

5-1. 2.4GHZ Radio System

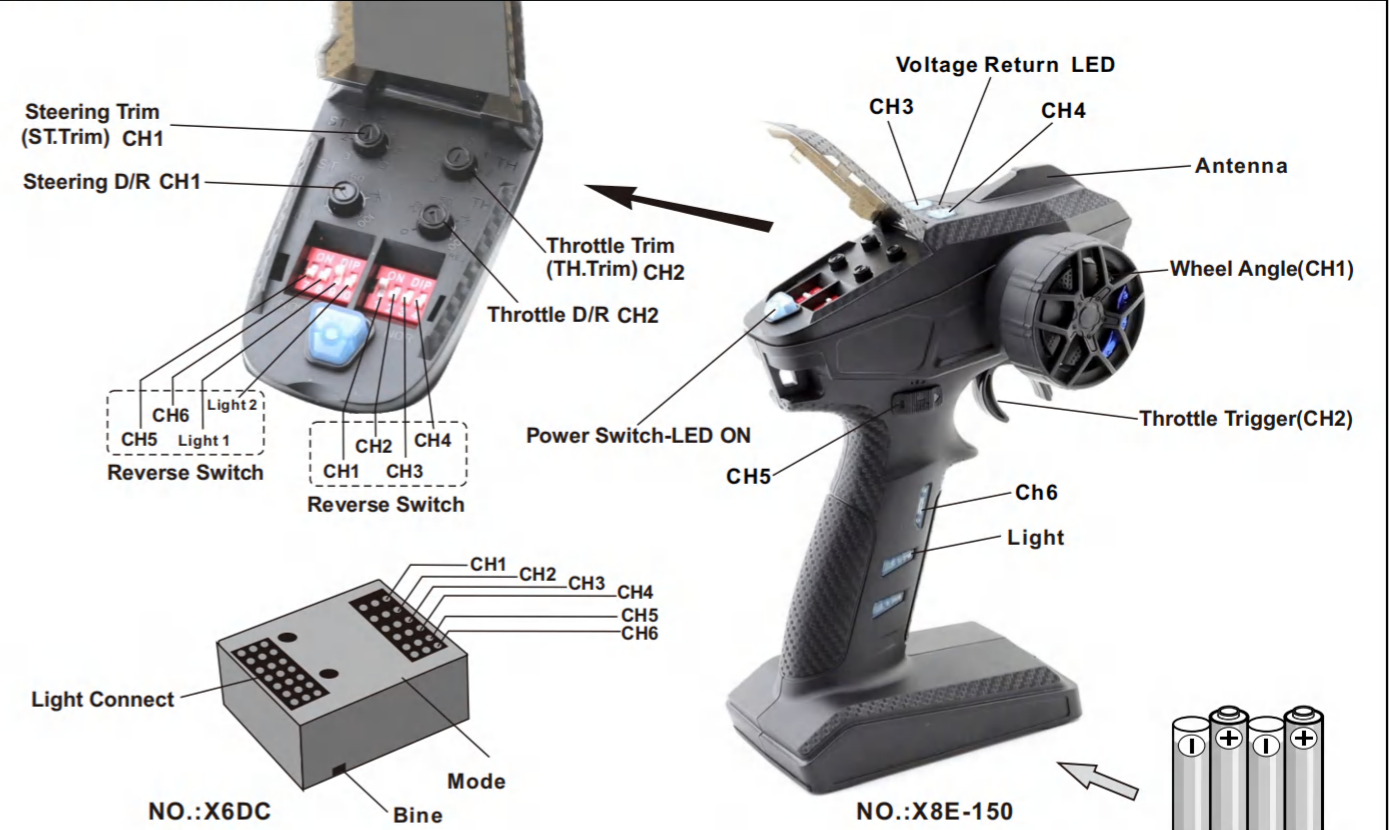

Install The Transmitter Batteries

- Battery Installation:**
1. Open the battery compartment cover.
 2. Insert 4 AA fully charged batteries or 2S Li-Po batteries in correct polarity. (No response if battery polarity reversed.)
 3. Close battery compartment cover.

Binding Process:

1. Press receiver button, LED indicator fast flashing means entering into binding mode, the receiver will automatically looking for the nearest transmitter signal.
2. The indicator will always ON after successful bond.

Batteries: 4 x 1.5 V "AA" (not included)

5-2. Transmitter Steering Trim and Throttle Trim

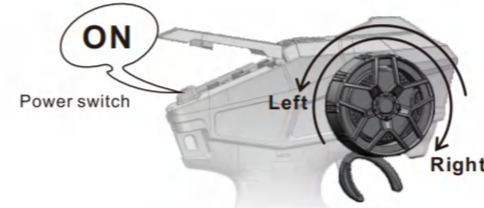

Wheel Angle
the maximum rotation of the Steering wheel is 35 degrees
From center to left or right
Throttle trigger,
has a total throw of 12 degrees,
12.5 degrees forward,
and 12.5 degrees backward
The heavier you pull or push the trigger,
the faster acceleration will be.
Note: Release the throttle trigger button,
activate the brake mode automatically.
(Only for Crawler)

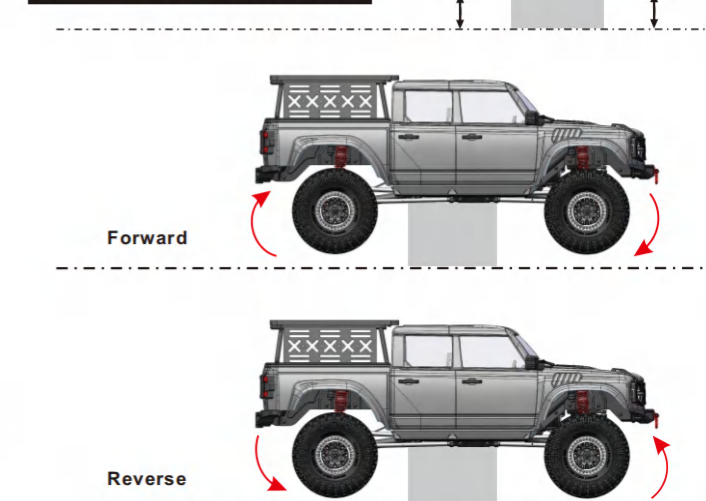
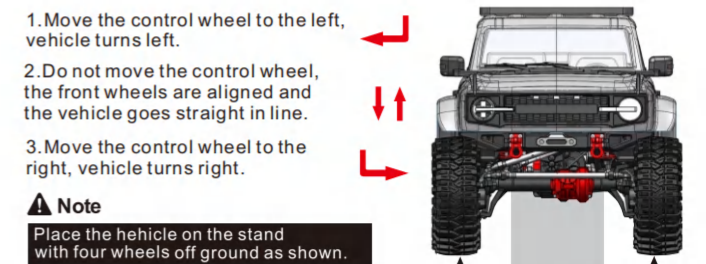
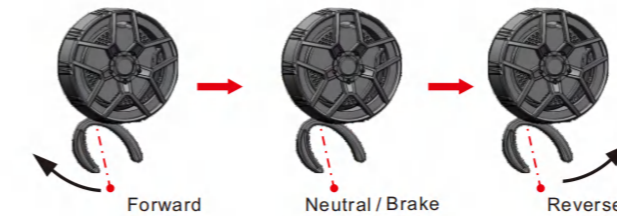

5-3. Transmitter Steering and Throttle Instruction

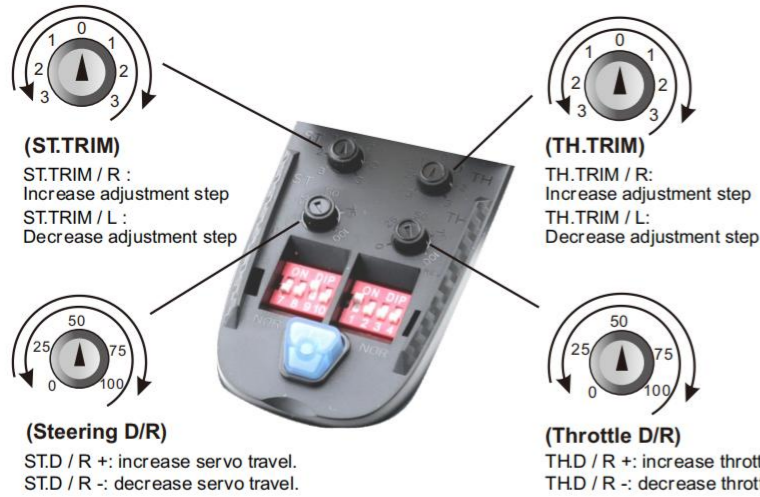

Note:

- Please trim the Throttle Trim (TH. Trim) until the vehicle stops in case the vehicle goes forwards or backwards itself just after it is turned on.
- If the front wheels are not aligned, please trim "steering trim" (ST.TRIM) until they are aligned.
- The ST.TRIM is the trims for Ch1(steering). You can trim the Steering Trim until it fulfills your desired steering angles.
- ST.D / R is for servo travel adjustment, which can be multiplexed as CH2 (throttle).

ST.REV

- Steering Trim(ST. Rev) is used to reverse the direction of servo movement.
- The ST.REV switches are the reverse buttons for Ch1. If the switch is up it indicates reverse, and the down indicates normal.

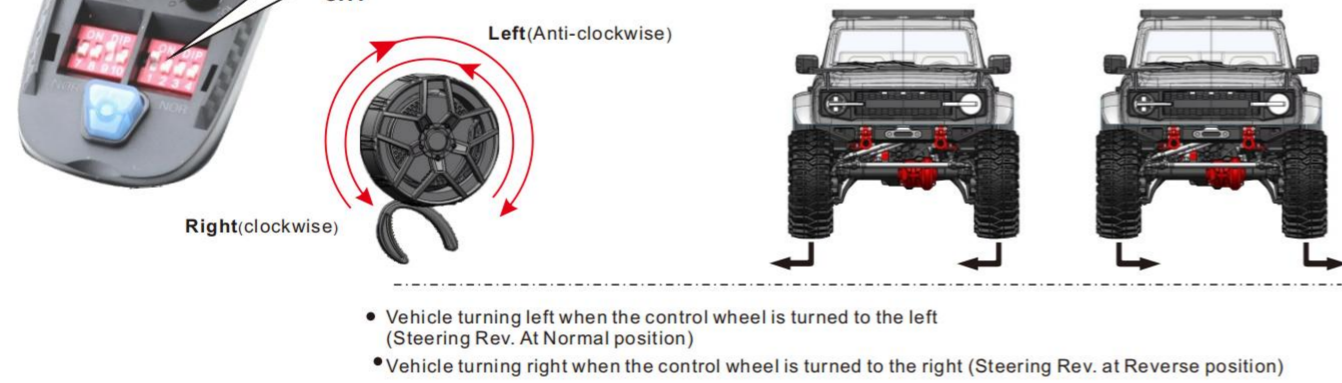

Channel Reverse TH.REV

- The Throttle Rev. is used to reverse the direction of motor rotation.
- The TH.REV switches are the reverse buttons for CH2. If the switch is up it indicates reverse, and the down indicates normal.

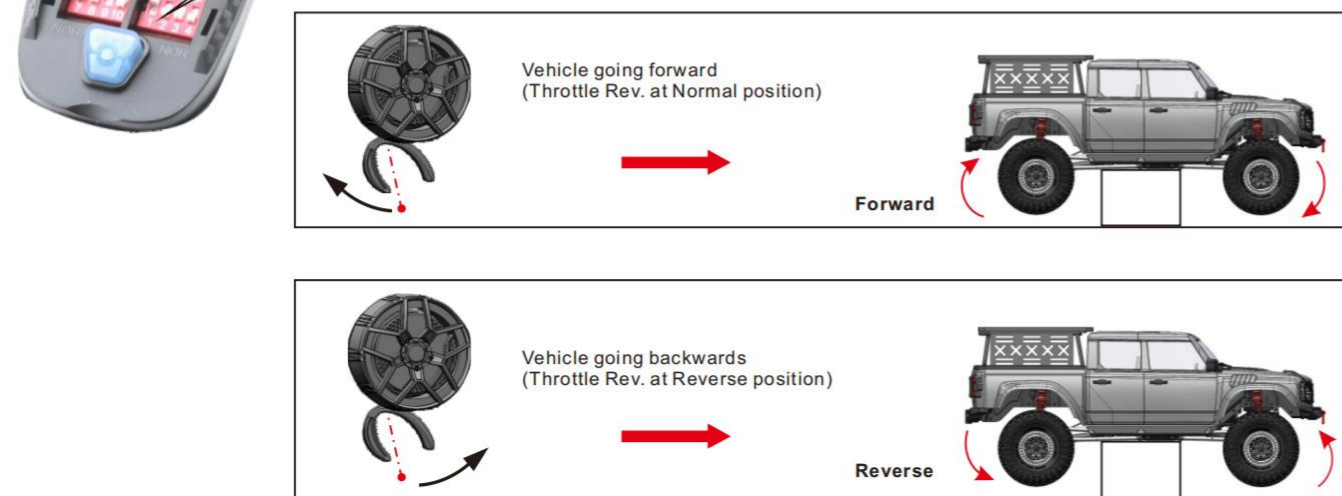

5-4. Operating the Lock Differentials

The switch on top of the transmitter operates CH3/CH4 the front and rear differential locking mechanism. The differentials can be locked or unlocked at any time during most driving conditions. If the model is stuck and there is wheelspin on a single wheel (one side of an unlocked differential is freewheeling), then release the throttle and allow the wheels to stop before locking the differential. Apply throttle slowly until the differentials fully engage or disengage.

! The front and rear diff lock is locked in factory. Ensure the vehicle in static or slow driving to avoid gear sweeping when conversion operation on the front and rear diff lock.

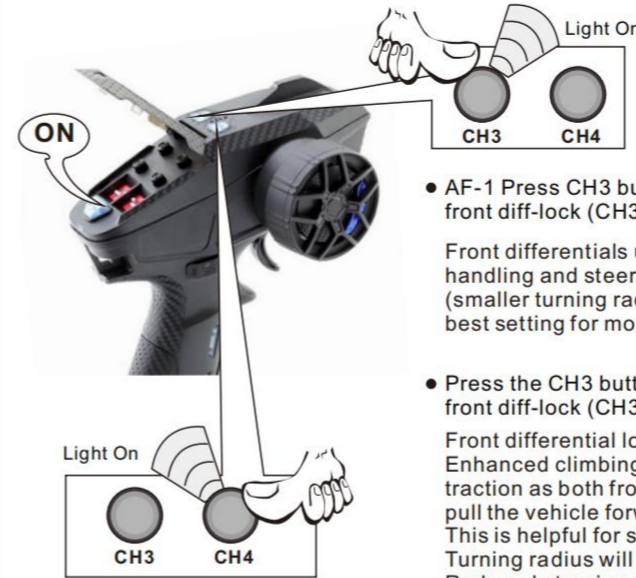

- AF-1 Press CH3 button, unlock the front diff-lock (CH3 button is on.)
Front differentials unlocked. Best handling and steering performance (smaller turning radius). This is the best setting for most of your driving.
- Press the CH3 button again, lock the front diff-lock (CH3 button is off.)
Front differential locked. Enhanced climbing ability and traction as both front tires work to pull the vehicle forward. This is helpful for steep inclines. Turning radius will be decreased. Reduced steering performance.

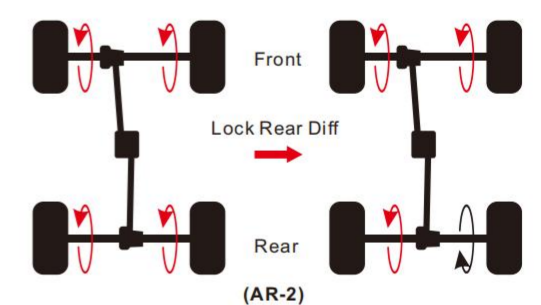
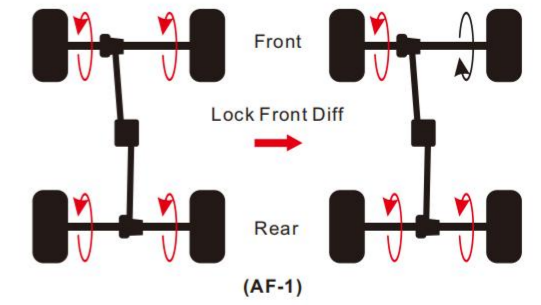

- AR-2 Press CH4 button, unlock the rear diff-lock (CH4 button is on.)
- Press the CH4 button again, lock the rear diff-lock (CH4 button is off.)
- AB-3 Press CH3 and CH4, unlock the front and rear diff-lock. (the button is on)
- Press CH3 and CH4 again, lock the front and rear diff-lock. (the button is off)

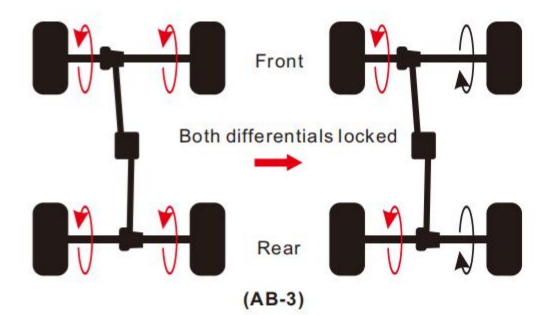

Both differentials locked. Maximum climbing ability and traction. Reduced steering performance. On surfaces with good traction, it is normal for the truck to appear to alternately bind and slip the tires when attempting tight turns with the differentials fully locked.

Locked differentials can be used at any time, but unlocking the differentials greatly improves vehicle handling during high-speed driving

5-5. Shifting the High-Low Transmission

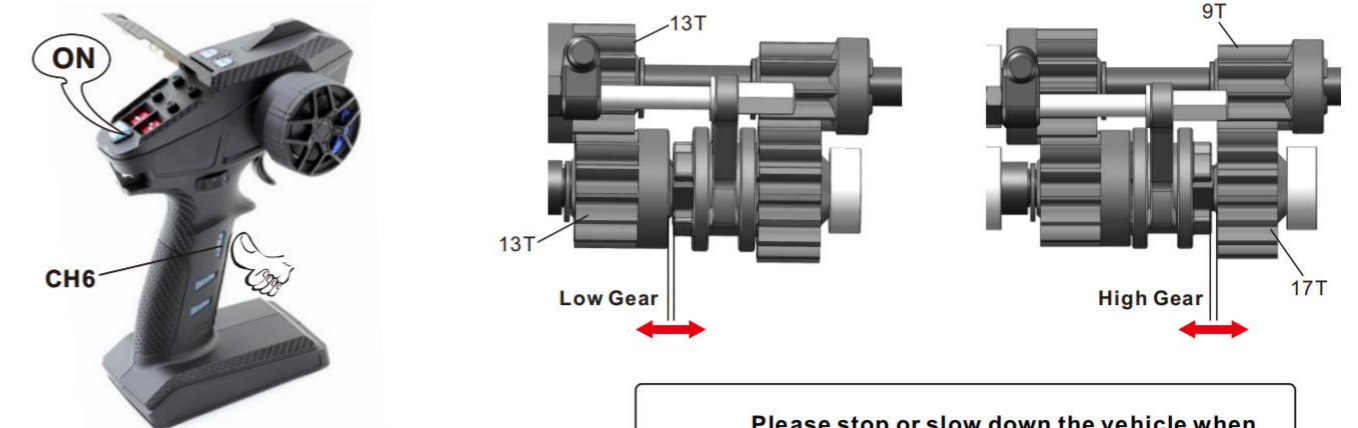

- Press CH6 button, the button light is on, switch to high-speed gear
- Press CH6 button again, the button light is off, switch to low-speed gear

! Please stop or slow down the vehicle when shifting gear, from low-speed to high-speed or from high-speed to low-speed, in order to make the shift operation more smoother and protect the gear.

5-6. Light Control Usage



(5-6A)

Model II :
As shown in image(5-6A), press the button, the front headlights are on; press the button again, the front headlights are flashing; press the button once again, the front headlights are off.



(5-6B)

Model III :
As shown in image(5-6B), press the button, DRLs are on; press the button again, DRLs are flashing; press the button once again, DRLs are off.



6. WP-880-Dual Brushed RTR

Model	WP-880-Dual Brushed RTR
Cont./Peak Current	80A/400A
Motor Type	Brushed Motor (540/550/775 size motors)
Applications	1/10th & 1/8th On-roads/ Buggies/Trucks/Monster Trucks/Rock Crawlers & Some Boats
Motor Limit	Brushed Motor Limit with 2S LiPo/6S NiMH: ≥12T or RPM<30000@7.4V (540/550 size motors) Brushed Motor Limit with 3S LiPo/9S NiMH: ≥18T or RPM<20000@7.4V (540/550 size motors) Brushed Motor Limit with 4S LiPo/12S NiMH: ≥24T or RPM<15000@7.4V (540/550 size motors)
LiPo/NiMH Cells	2-4S LiPo or 5-12S NiMH
BEC Output	7.4V@4A (Switch-mode)
Size/Weight (w./ Wires)	45.9mm(L)*34.7mm(W)*26.5mm(H)/ 75g
Programming Port	Separate Port

6-1. Programmable Items

Those "White text with Black background" options are the factory default settings

Programmable Items	Option 1	Option 2	Option 3	Option 4	Option 5	Option 6	Option 7	Option 8	Option 9
Running Mode	Fwd/Brk	Fwd/Rev /Brk	Fwd/Rev						
Battery Type	LiPo	NiMH							
Cutoff Voltage	Disabled	Auto(Low)	Auto (Medium)	Auto (High)					
Initial Start Force	0%	2%	4%	6%	8%	10%	12%	14%	16%
Max. Forward Force	25%	50%	75%	100%					
Max. Reverse Force	25%	50%	75%	100%					
Max. Brake Force	0%	12.5%	25%	37.5%	50%	62.5%	75%	87.5%	100%
Initial Brake Force	0%	6.25%	12.5%	18.75%	25%	31.25%	37.5%	43.75%	50%
Drag Brake	0%	5%	10%	50%	60%	70%	80%	90%	100%
Drag Brake Rate	Level 1	Level 2	Level 3	Level 4	Level 5	Level 6	Level 7	Level 8	Level 9
Neutral Range	0.02ms	0.03ms	0.04ms	0.05ms	0.06ms	0.07ms	0.08ms	0.10ms	0.12ms
Start Mode/Punch	Level 1	Level 2	Level 3	Level 4	Level 5	Level 6	Level 7	Level 8	Level 9
PWM Frequency	1K	2K	4K	8K	16K				
BEC Voltage	7.4V								
Freewheeling/ DEO	Enabled	Disabled							

1).Running Mode

Option 1: Forward with Brake

It's a racing mode. It has only forward and brake functions.

Option 2: Forward/ Reverse with Brake

This option is known to be the "training" mode with "Fwd/Rev/Brk" functions. We have adopted the "DOUBLE-CLICK" method, that is your vehicle only brakes on the 1st time you push the throttle trigger forward (brake) (1st push). The motor stops when you quickly release the throttle trigger and then re-push the trigger quickly (2nd push), only then the vehicle will reverse. The reverse function will not work if your car does not come to a complete stop. The vehicle only reverses after the motor stops. This method is for preventing vehicle from being accidentally reversed.

Option 3: Forward and Reverse

This mode is often used by special vehicles (rock crawler). It adopts the "SINGLE-CLICK" method. The vehicle will reverse immediately when you push the throttle trigger forward (brake).

2).Battery Type

This item provides two options: **LiPo & NiMH**, please select as per your battery and set the cutoff voltage accordingly.

3).Cutoff Voltage

This item is mainly for preventing the LiPo battery from irreversible damage due to over discharge. The ESC monitors the battery voltage all the time, it will immediately cut off the output when the voltage goes below the cutoff threshold. The Red LED will flash " , , " when the low-voltage cutoff protection is activated. When the "Battery Type" is set to "LiPo", the voltage corresponds to "Auto (Low)/Auto (Medium)/Auto (High)" is 3.0V/3.2V/3.4V per cell; when the "Battery Type" is set to "NiMH", the voltage corresponds to "Auto (Low)/Auto (Medium)/Auto (High)" is 4.5V/5.0V/5.5V (for the whole NiMH pack).

4).Initial Start Force

It's the initial force when you pull the throttle trigger from neutral position toward non-throttle throttle position. A suitable start force can effectively prevent vehicle from sliding when you apply a low throttle amount.

5).Max. Forward Force

It's the force when throttle trigger is at the full throttle position. It's adjustable among 25%, 50%, 75% and 100% (by default). You can lower down the value for better driving feel/control when you drive a crawler (simulation model) over difficult terrains (and don't have any requirement against the maximum speed).

6).Max. Reverse Force

Different reverse amount will bring different reversing speed. For the safety of your vehicle, we recommend using a low amount.

7).Max. Brake Force

The ESC provides proportional braking function; the braking effect is decided by the position of the throttle trigger. It sets what percentage of available braking power when full brake is applied. Large amount will shorten the braking time but it may damage your pinion and spur. Please select the most suitable brake amount as per your car condition and your preference.

8).Initial Brake Force

It's also known as "min. brake force". It's the force when pushing throttle trigger from neutral zone to the initial brake position.

9).Drag Brake

Drag brake is the braking power produced when releasing the throttle trigger from full speed to neutral zone. (Attention! Drag brake will consume much power, so apply it cautiously.)

10).Drag Brake Rate

It's the rate at which the drag brake increases from zero to the pre-set value when the throttle trigger enters the neutral range. A suitable rate can make the vehicle stop stably. You can choose the drag brake rate from level 1 (very soft) to level 9 (very aggressive) as per the track, tires' grip, and etc.

11).Neutral Range

As not all transmitters have the same stability at "neutral position", please adjust this parameter as per your preference. You can adjust to a bigger value when this happens.

12).Start Mode / Punch

You can choose the punch from level 1 (very soft) to level 9 (very aggressive) as per the track, tires, grip, your preference and etc. This feature is very useful for preventing tires from slipping during the starting-up process. In addition, "level 7/8/9" have strict requirement on battery's discharge capability. It may affect the starting-up if the battery discharges poorly and cannot provide large current in a short time. The car stutters or suddenly loses power in the starting-up process indicating the battery's discharge capability is not good, and then you need to reduce the punch or increase the FDR (Final Drive Ratio).

13).PWM Drive Frequency

The acceleration will be more aggressive at the initial stage when the drive frequency is low; a higher drive frequency is smoother but this will create more heat to the ESC.

14).BEC Voltage

This item is not programmable and fixed at 7.4V.

15).Freewheeling/DEO

For regular vehicles, we recommend disabling this function. With it disabled, your vehicle can have quick acceleration. For a crawler (simulation model), we suggest enabling it. With it enabled, you crawler can have better linearity during a low-speed running and also less heat.

6-2. ESC Programming

Program your ESC with a LED program card

The LED program card is an optional accessory for updating the firmware of car ESCs. Its friendly interface makes the ESC programming easy and quick. Before the programming, you need to connect your ESC to the program card via a White/Red/Black PVC cable with two JR male connectors (one end of the cable to the separate programming port on the ESC and the other end to the port marked with " " on the program card), and then turn on the ESC, all programmable items will show up a few seconds later. You can select the item by choosing via "ITEM" & "VALUE" buttons on the program card. Press the "OK" button to save all new settings to your ESC.

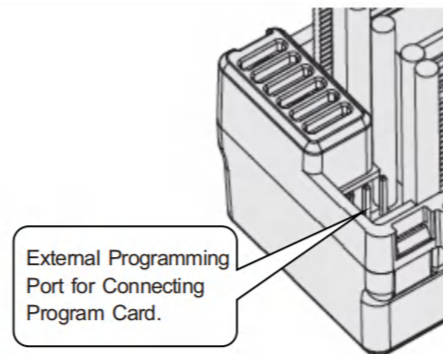

6-3. Factory Reset

Restore the default values with a LED program card

After connecting the LED program card to the ESC, press the "RESET" button and the "OK" button to factory reset your ESC.

6-4. Troubleshooting

Trouble	Possible Cause(s)	Solution(s)
The ESC was unable to start the status LED and the motor after it was powered on.	<ol style="list-style-type: none"> 1. No power was supplied to the ESC. 2. The ESC switch was damaged. 	<ol style="list-style-type: none"> 1. Check if all ESC & battery joints or connections have been well soldered or firmly connected, re-solder them if necessary. 2. Replace the broken switch.
The ESC was unable to start the motor (but the Red status LED flashed) after it was powered on.	The throttle control cable was reversely plugged in or in the wrong channel on the receiver, or the throttle stick/trigger was not moved to the neutral position.	Plug the throttle control cable in the TH channel on receiver, or fine-tune the neutral position, if the transmitter supports the "forward/reverse or backward" proportion setting, then you need to set the proportion to 5:5.
The vehicle ran backward when you pulled the throttle trigger towards you.	<ol style="list-style-type: none"> 1. The ESC-to-motor wiring order was incorrect. 2. Incorrectly set the direction of the throttle channel. 	<ol style="list-style-type: none"> 1. Swap the two motor wires. 2. Change the direction of the throttle channel from "NOR" to "REV" or "REV" to "NOR".
The motor suddenly stopped or significantly reduced its output in operation.	<ol style="list-style-type: none"> 1. The receiver was influenced by some foreign interference. 2. The LVC protection was activated. 3. The ESC thermal protection was activated. 	<ol style="list-style-type: none"> 1. Check all devices to find out all possible causes, and check the transmitter's battery voltage. 2. The Red LED keeps flashing indicating the LVC protection is activated, so please replace your battery pack. 3. The Red LED keeps flashing indicating the ESC thermal protection is activated, please let your ESC cool down before using it again.
The vehicle could run forward but could not reverse.	<ol style="list-style-type: none"> 1. The throttle neutral position on your transmitter was actually in the braking zone. 2. Set the "running mode" improperly. 3. The ESC was damaged. 	<ol style="list-style-type: none"> 1. Re-calibrate the throttle neutral position, no LED on the ESC will turn on when the throttle trigger /stick is at the neutral position. 2. Set the "running mode" to "Fwd /Rev/Br" or "Fwd/Rev". 3. Contact your dealer for repair service.
The vehicle moved forward or backward slowly when the throttle trigger was at the neutral position.	<ol style="list-style-type: none"> 1. The signals emitted by the transmitter were not stable. 2. The throttle range was not calibrated properly. 	<ol style="list-style-type: none"> 1. Replace the transmitter with another one that has stable signals. 2. Please fine-tune the neutral position on the transmitter.
The LED display kept displaying "---" after the LED program card was connected to the ESC.	Connected the LED program card to the wrong port on the ESC.	Connect the LED program card to the separate port marked with " ⊕ ⊖ ⊔ " on the ESC.

7. Specifications

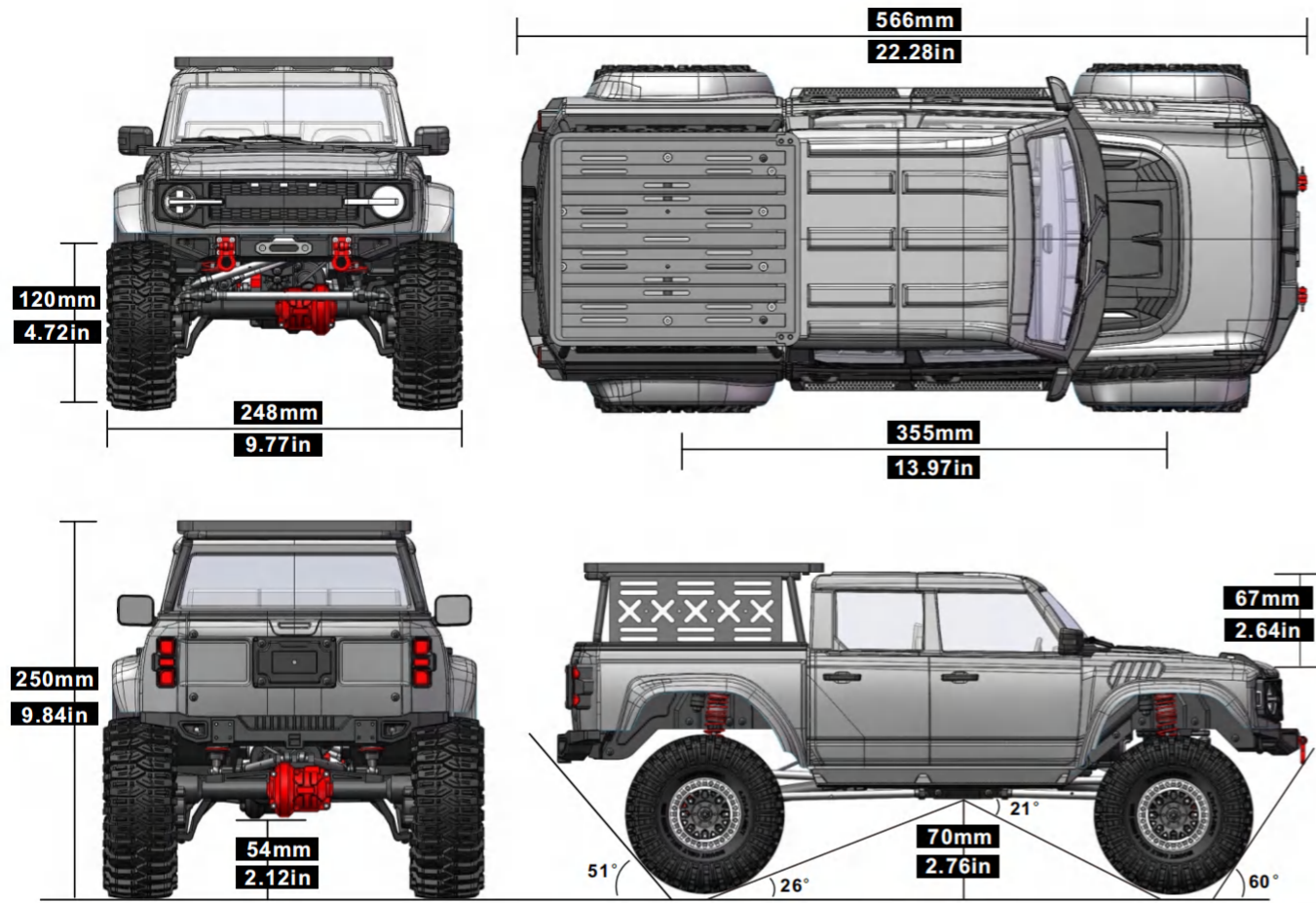

Item No	Ex86150	Wheel	120*45mm	Motor	550/8020
Item Name	PATHFINDER	Clearance	70mm(classis) 54mm (steel)	Servo	30kg*1p/ 9g*3p
Scale	1/10	Weight	3.68kg(No battery)	Gead Ratio	26.6:1(HS), 50.4:1(LS)
Desciption	RTR-Crawler	Radio/Rx	2.4G/6CH	Breakover	21°
Drive Type	4WD	R/C Distance	<120m>100m	Approach	60°
Length	566mm	Battery Recommendations	2S or 3S Lipo, 5-9 Cells NIMH Battery	Departue	51°
Width	248mm	Battery Size	<142*48*55mm(L*W*H)	Body Color	PC Red/Green /Gray
Height	250mm	Number Of Differentials	"Steel" 2P	Gift Box Size	630*285*325mm
Wheel Base	355mm	ESC	WP-880 / 80A	Piece per Carton	1P

8. All the ways done,your car is ready to run. Hope you enjoy the fun in driving it.

Tip: Always turn off the receiver and then the transmitter when not in use. Clean the car before storage.

Vehicle Maintenance:

- 1).Please remove the batteries from both the vehicle and the transmitter, when the car is out of use for a long time.
- 2). Before each use, please carefully check whether the circuit wires of the model are tight and free of loose connectors. Also, please carefully inspect if the wheels are securely fastened-loose wheels can cause excessive wear to parts such as the drive shaft, wheel cups, or wheel hubs.
- 3). Ensure the unused battery pack should be charged to 50-60% capacity before being stored in a dry and cool place, out of the reach of children.
- 4). After each use, please carefully check if all parts are intact, and repair or replace the worn parts. Use a fine brush to sweep the sand, marl and other dirt inside the model, then wipe it cleanly by a soft cloth.

9. Troubleshooting

Problem	Possible Cause	Solution
Car does not respond during operation	Electronic plugs loose or fall off	Switch off and reconnect
	Vehicle battery not charged, activating the ESC low voltage cut-off to protect the battery	Replace/recharge the vehicle battery
	Motor or ESC dirty or damaged	replace new Motor (recommend to purchase factory Motor)
	ESC failed	replace new ESC (recommend to purchase factory ESC)
	ESC power off by overheated Motor	Stop operation and cool the ESC or Motor
	Motor overheated, demagnetized or damaged	replace new Motor (recommend to purchase factory Motor)
	Transmitter batteries low or beyond the remote control distance	Replace the transmitter batteries, adjust the remote control distance
No Backward, forward normally	Transmitter damaged	Relace or contact seller
	ESC "operation mode" setting error	Refer to manual "ESC" , set "operation mode " into "forward and backward reverse with brake"
	ESC damaged	Relace or contact seller
Car operate automatically, with no control	Throttle damaged or transmitter throttle not centered	Refer to manual "Transmitter", and reset
	Throttle trim out of center on transmitter	Refer to manual "Transmitter", and reset
Normal operation, speed shift failure	Neutral throttle is in incorrect position	Adjust ESC in neutral point
	Error Operation	Ensure to operate in stop status, more refer to the Manual
Sluggish Action	Gear Cable damage or loose	Replace the accessory or Readjust
	Servo wire inserts in wrong Receiver slot	Refer to the manual, Readjust
	Drivetrain dirty / damaged	Check and clean
Light Function Failure after Battery properly installed	Battery damaged / not charged	Check, change or recharge
	Throttle trim out of center on transmitter	Adjust (refer to manual "transmitter")
	Motor dirty/ damaged	Clean/ replace
Lack of steering and throttle	Light Plug is not connected or in wrong postion	Check the plug connection
	Transmitter Set Error or Light Control Panel Damage	Reset the Transmitter. Otherwise, please check the light control panel is damaged or not.
	Light Cable in wrong installation and connection	Readjust the installation and Connection
Vehicle moves left / right without steering input	ESC power off by overheat	Stop operation, cool the ESC
	Transmitter too near interfere electronical objects	Check and rebind transmitter and receiver, refer to manual
Controls Reversed	Steering accessories damaged	Check and replace
	ST. REV or TH. REV	Change switch position, refer to manual
	Wheel loose	Check and replace
Clicking noise in operation	Drivetrain dirty / damaged	Check and replace
	Check the wires between ESC and Motor correct or not	Switch the motor black and red wire
Only steering, no forward and backward	Check the bodysell damaged or fall off	Retrim or replace
	Loose or tight between motor gear and main gear	Reset gear mesh
Only steering, no forward and backward	Gear damaged or rocked	Remove gear cover and inspect. If necessary, replace gear
	ESC failed or abnormal	Reset the neutral point or replace
Only steering, no forward and backward	Transmitter failed or abnormal	Relace or contact seller

Transmission Assembly-1

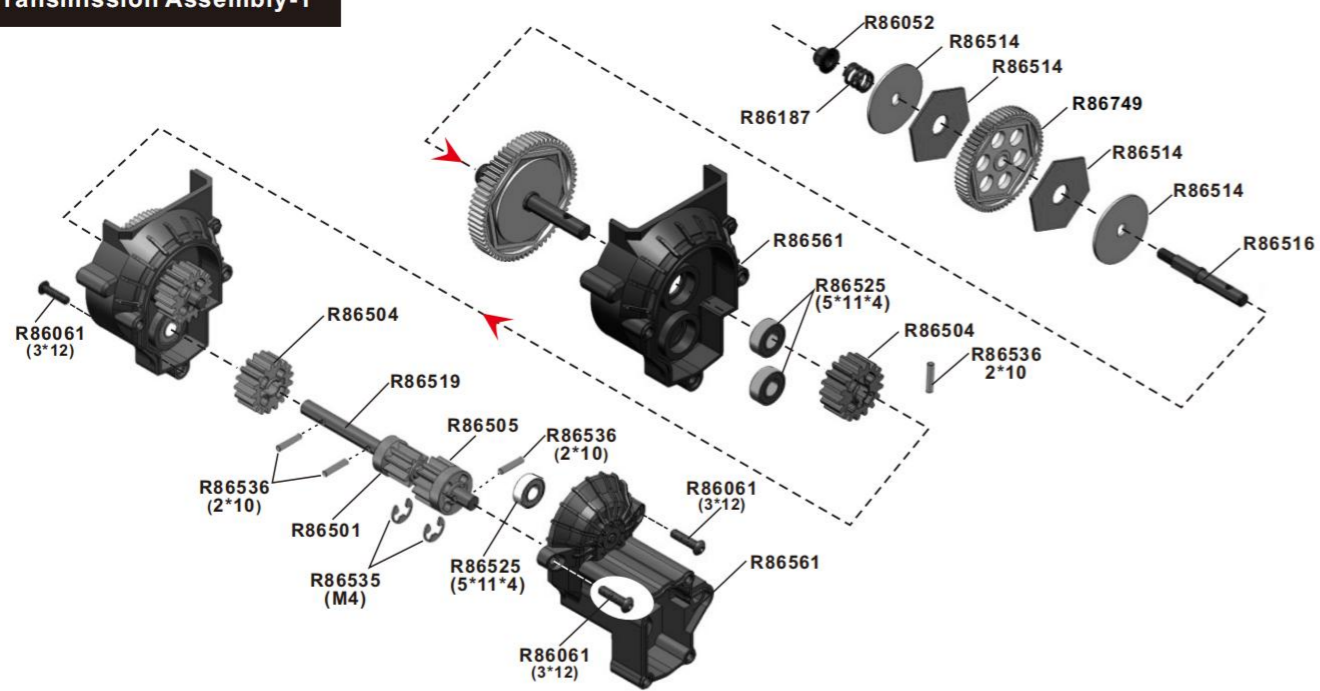

Transmission Assembly-2

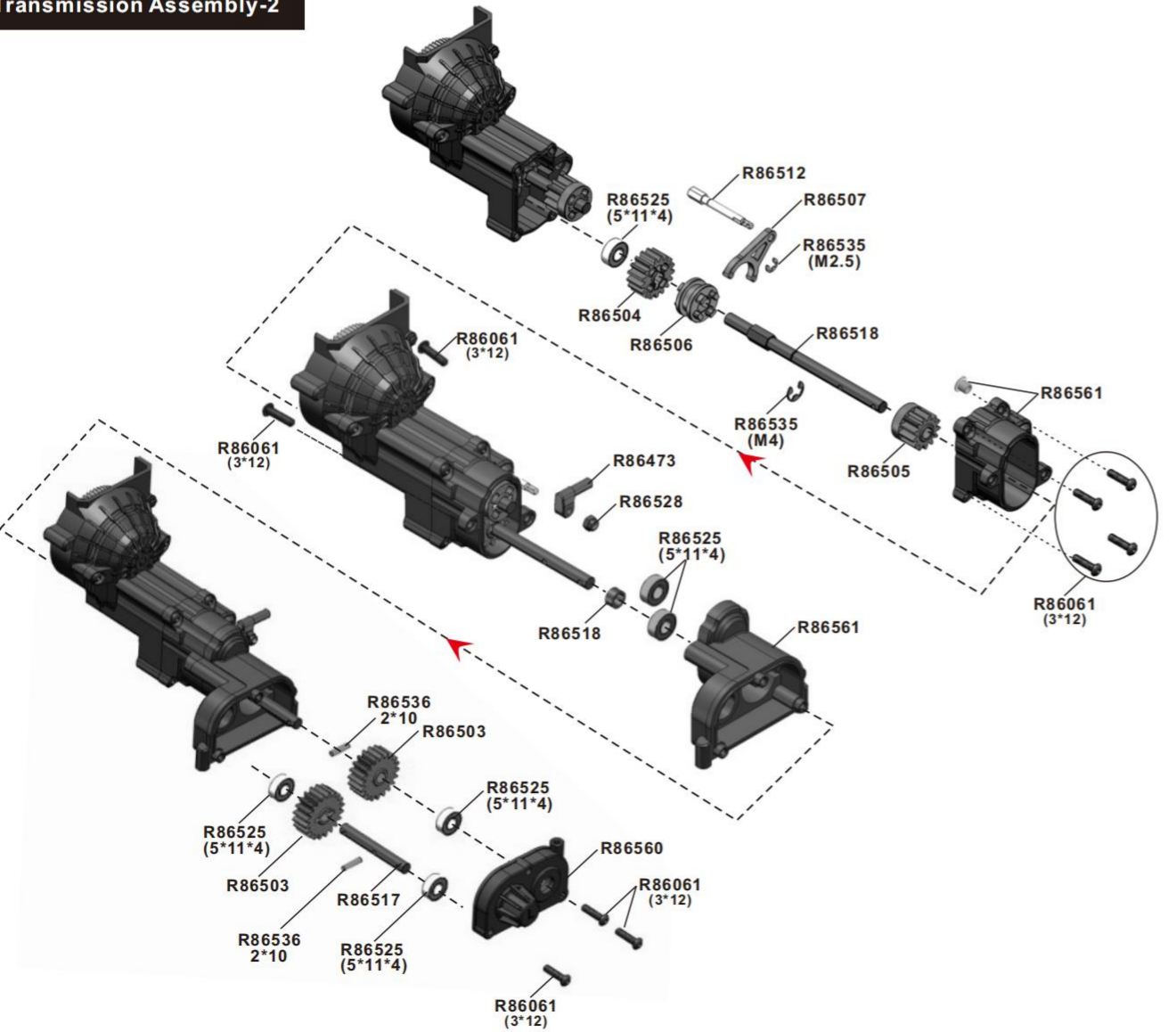

Motor/Transmission Assembly

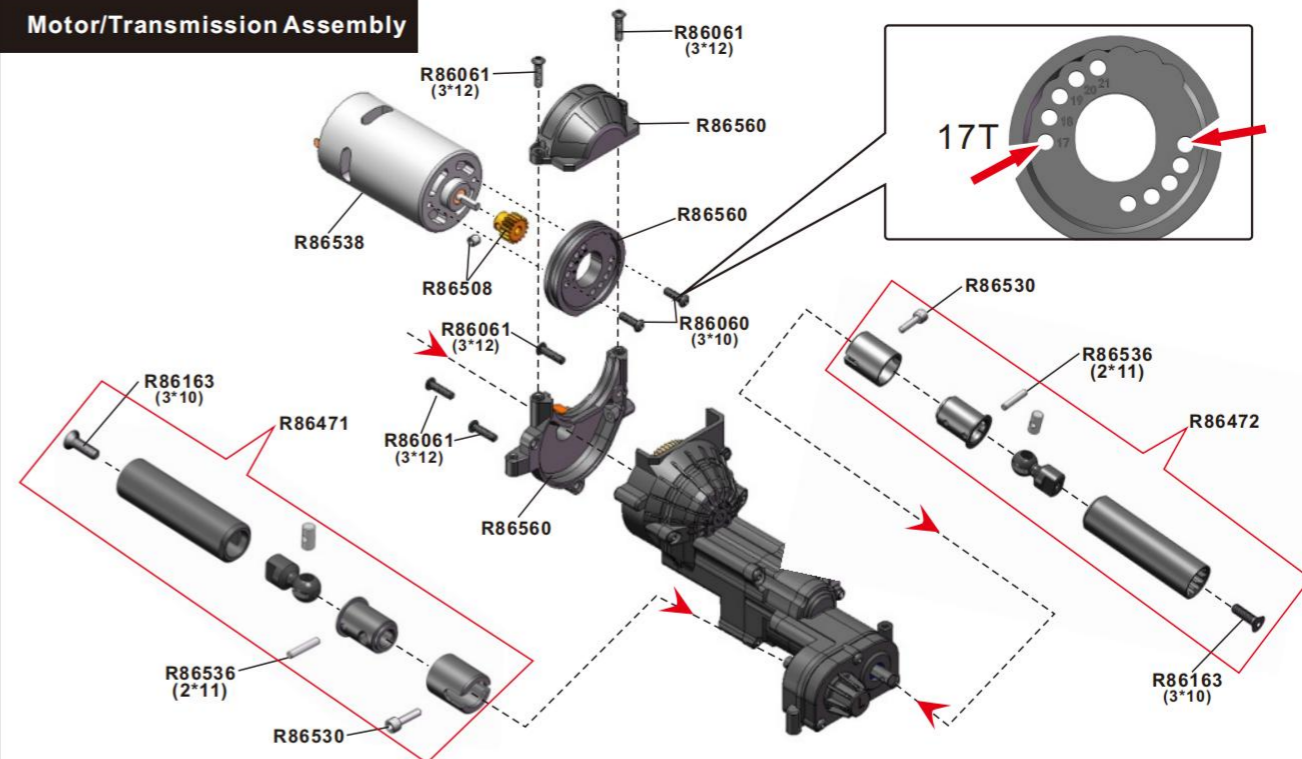

Diff.gear Assembly

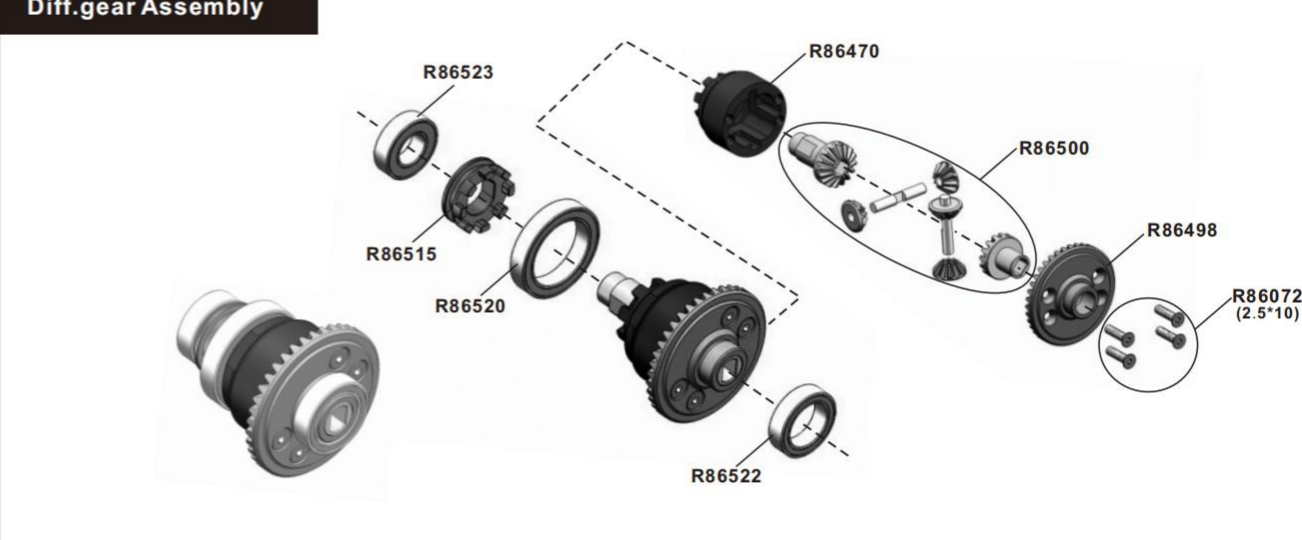

Front Axle Assembly

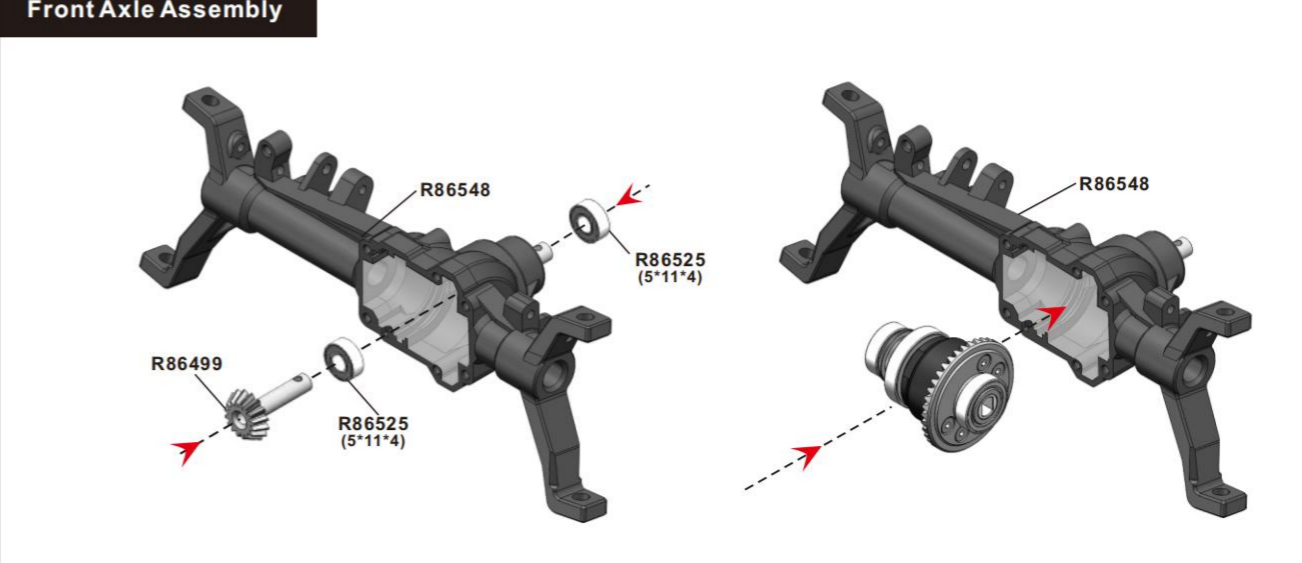

Rear Axle Assembly

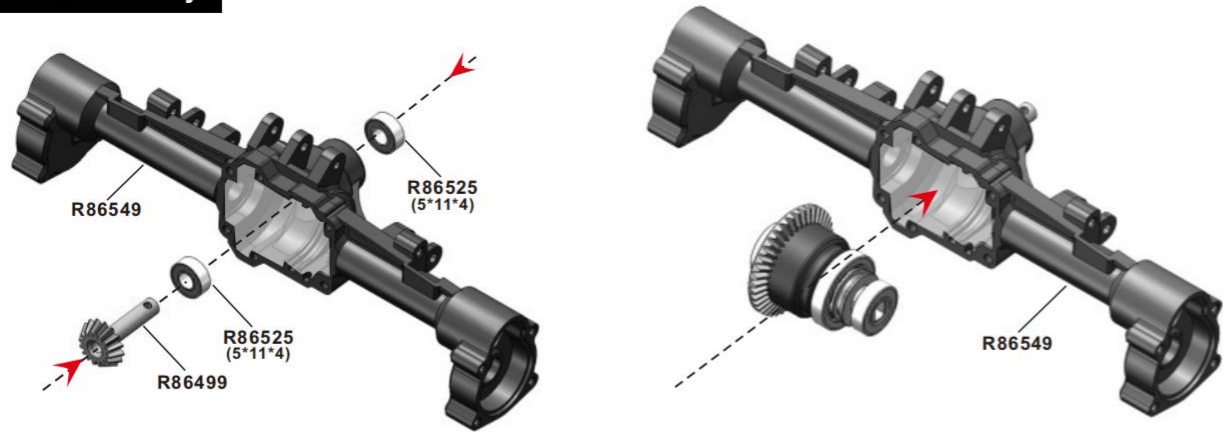

Diff.Lock Line Assembly (Front)

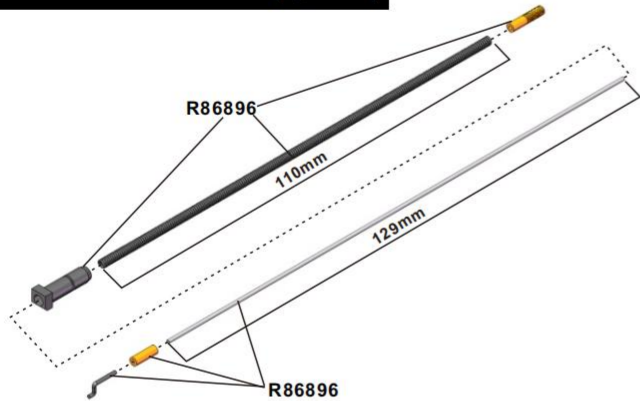

Diff.Lock Line Assembly (Rear)

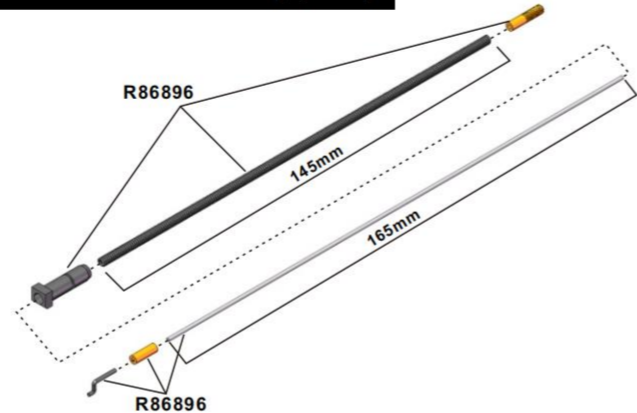

Diff. Lock Clasp (F-1)

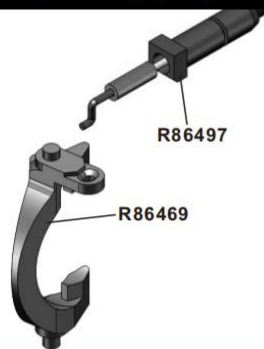

Diff. Lock Clasp (F-2)



Diff. Lock Clasp (R-1)



Diff. Lock Clasp (R-2)

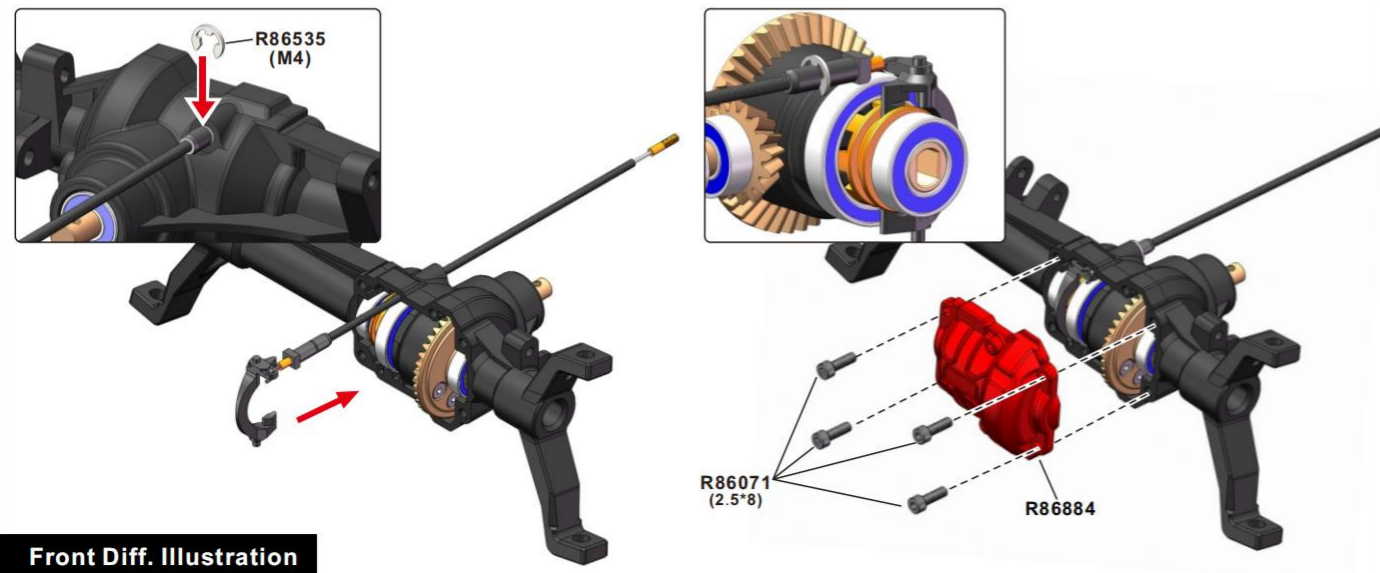

Front Diff. Illustration

Rear Diff. Illustration

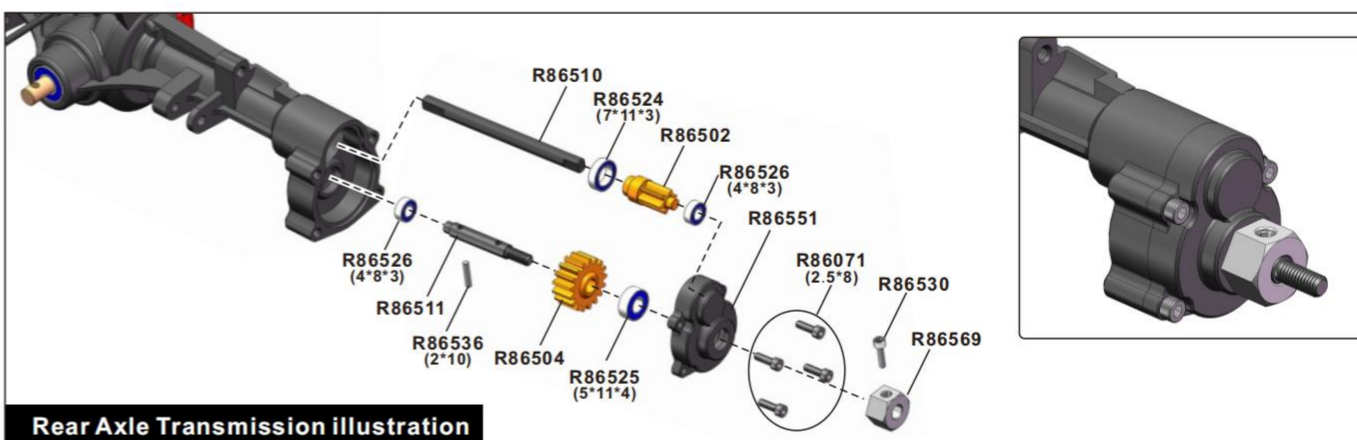
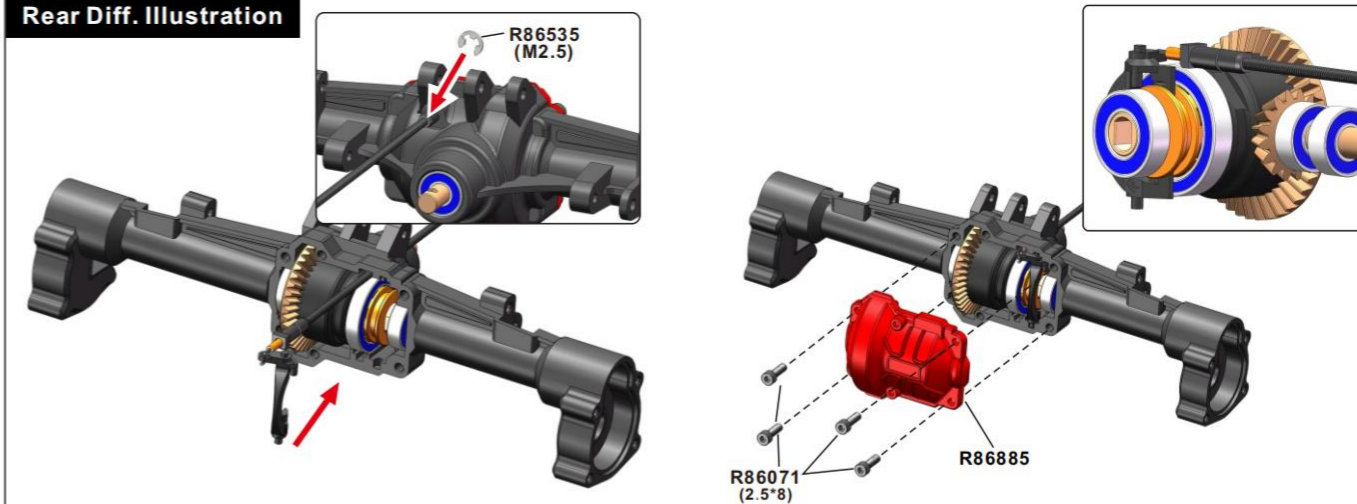

Rear Axle Transmission illustration

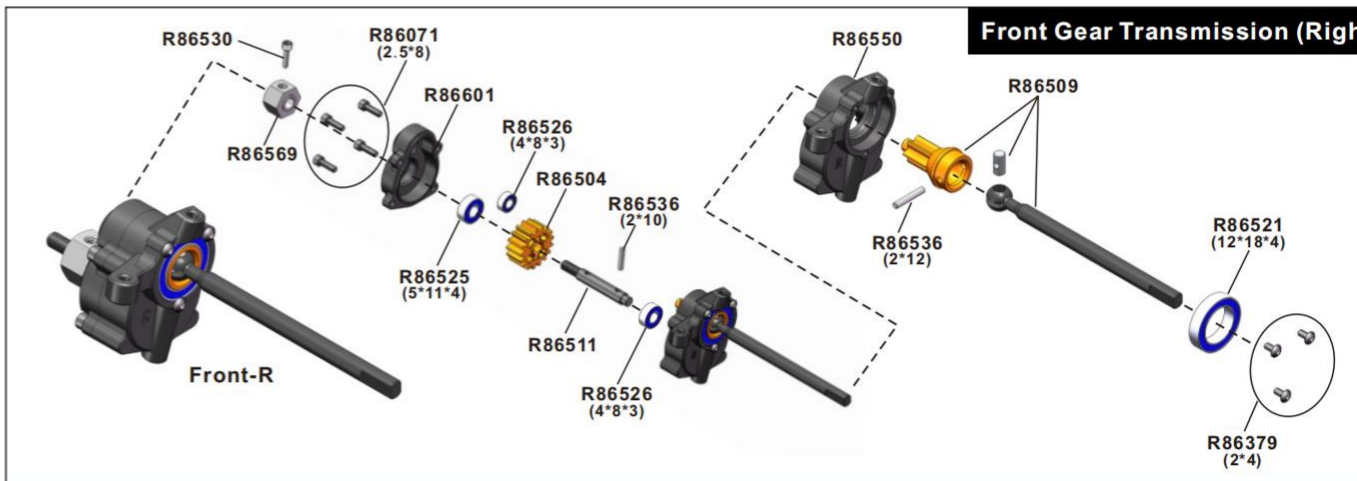

Front Gear Transmission (Right)

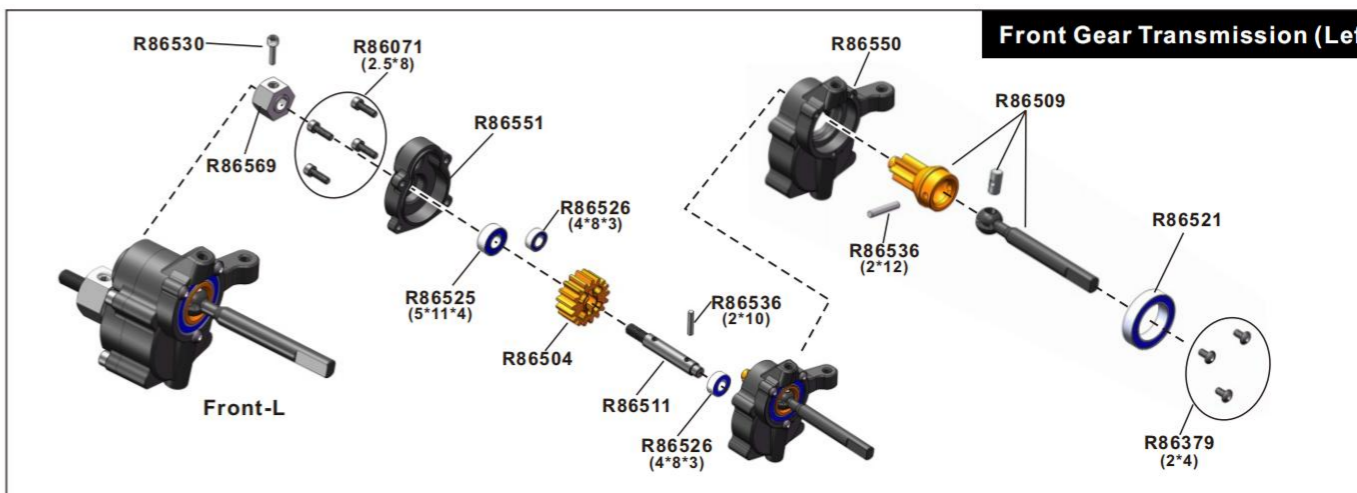

Front Gear Transmission (Left)

Shock Absorber Assembly

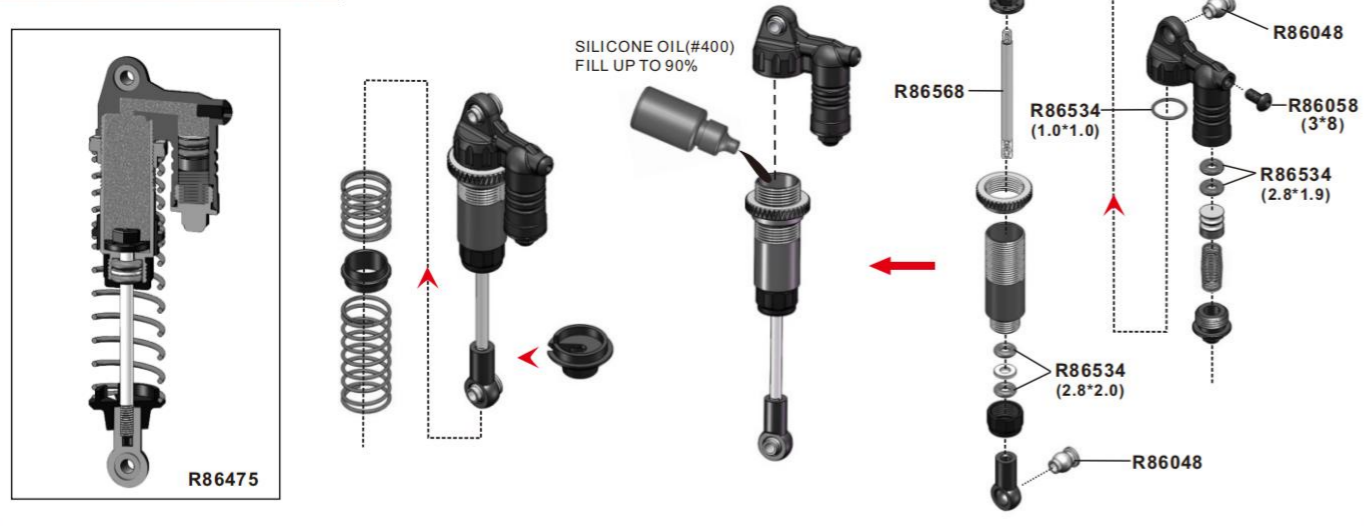

Front Axle Assembly

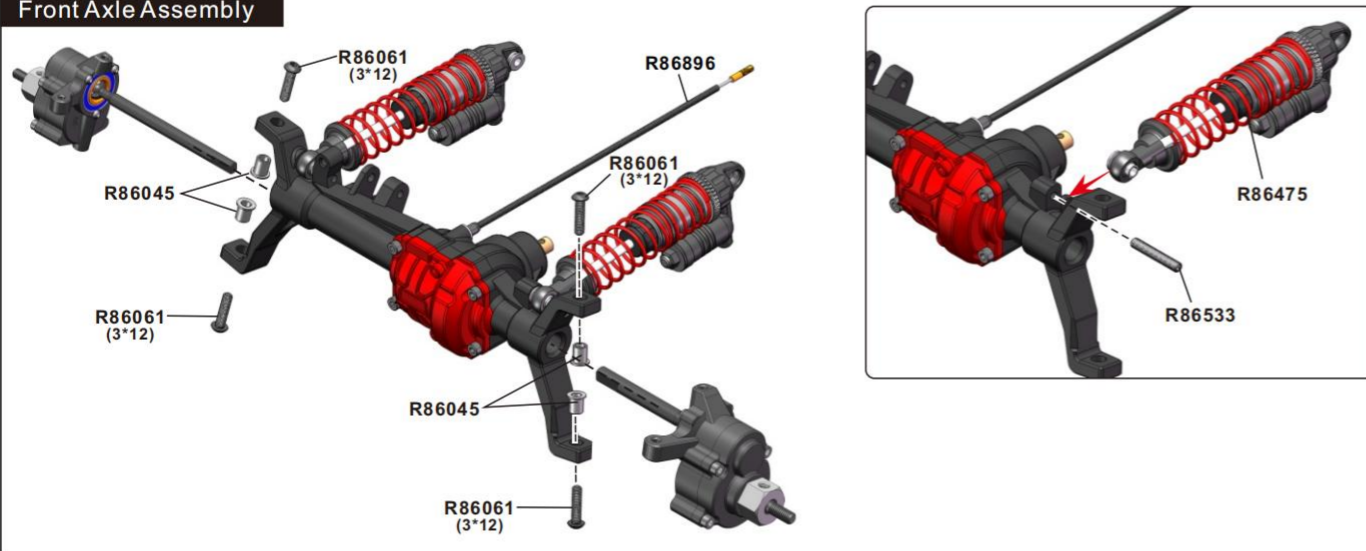

Linkage Bar Assembly

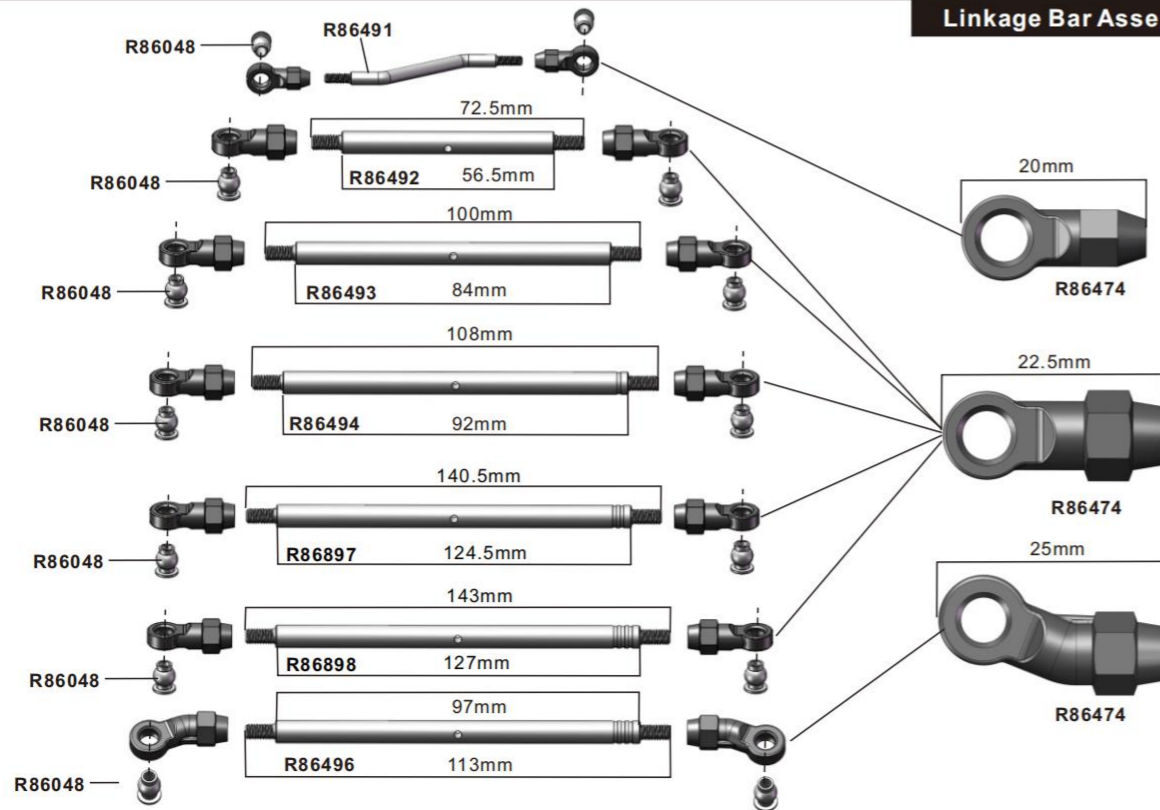

Front Steering Linkage Installation

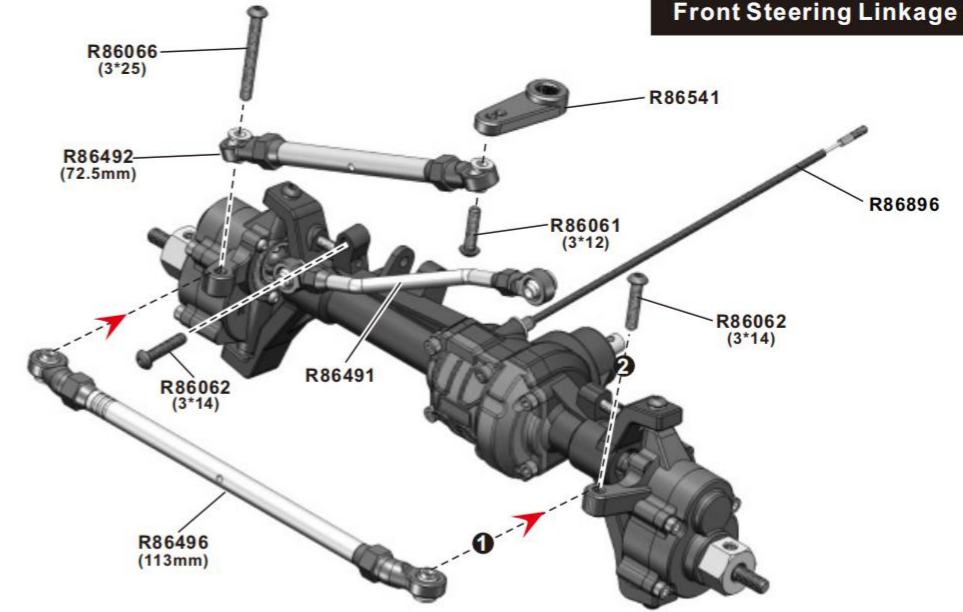

Front Suspension Linkage Installation

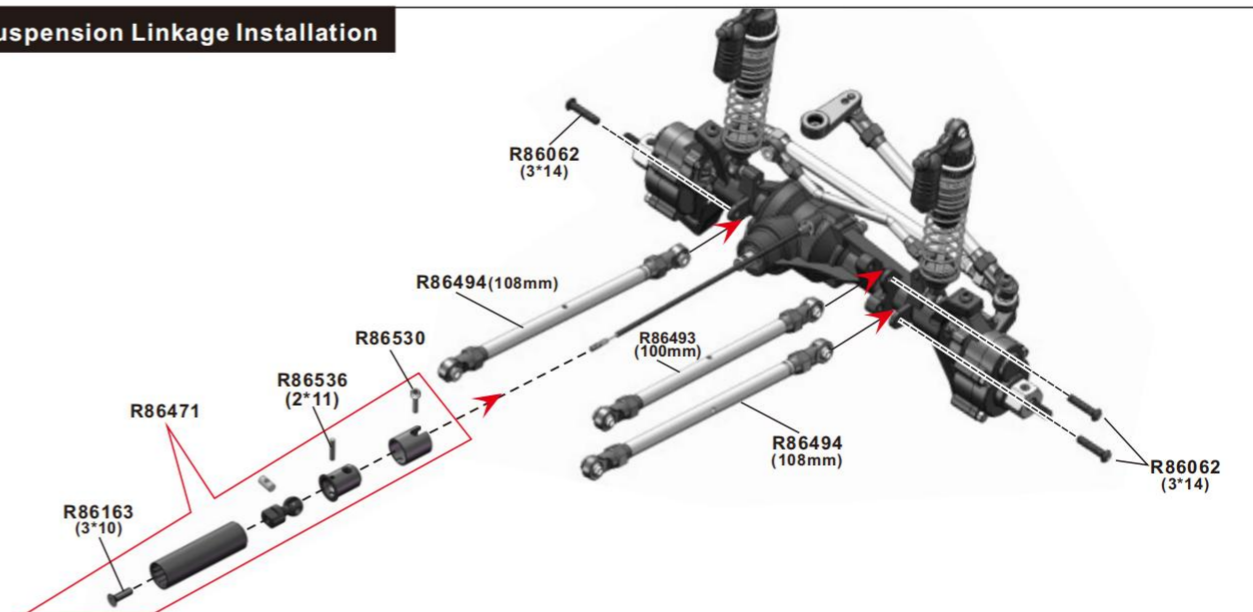

Rear Suspension Linkage Installation

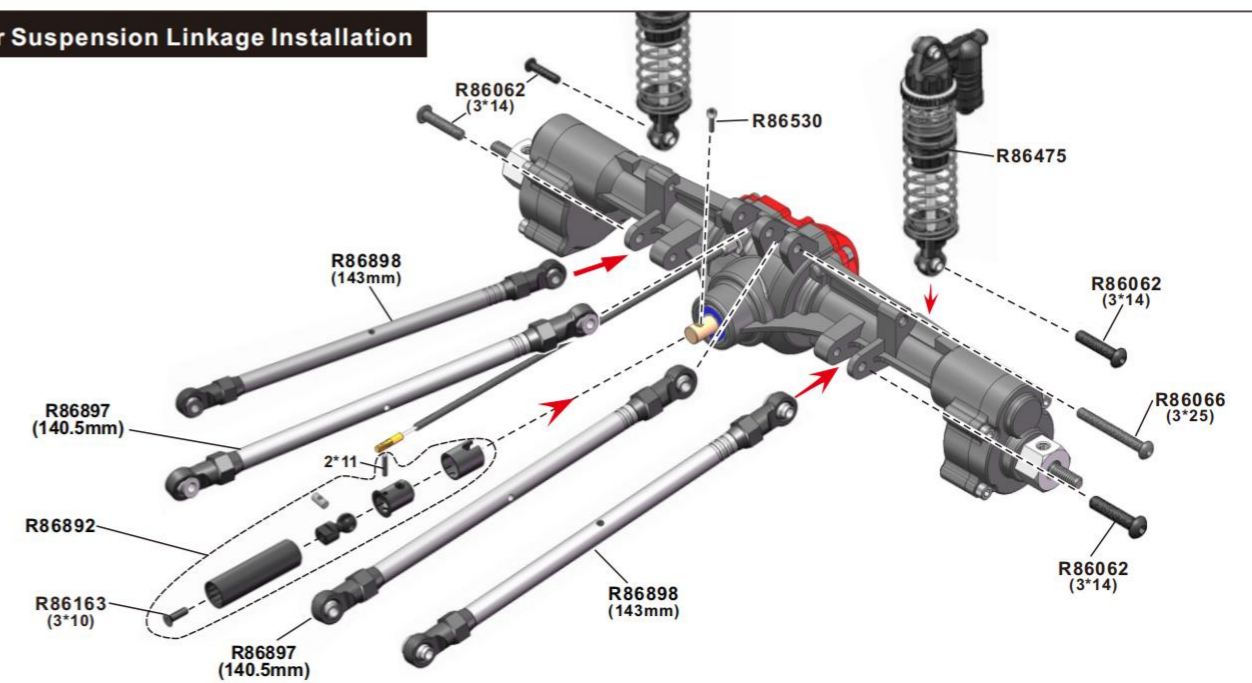

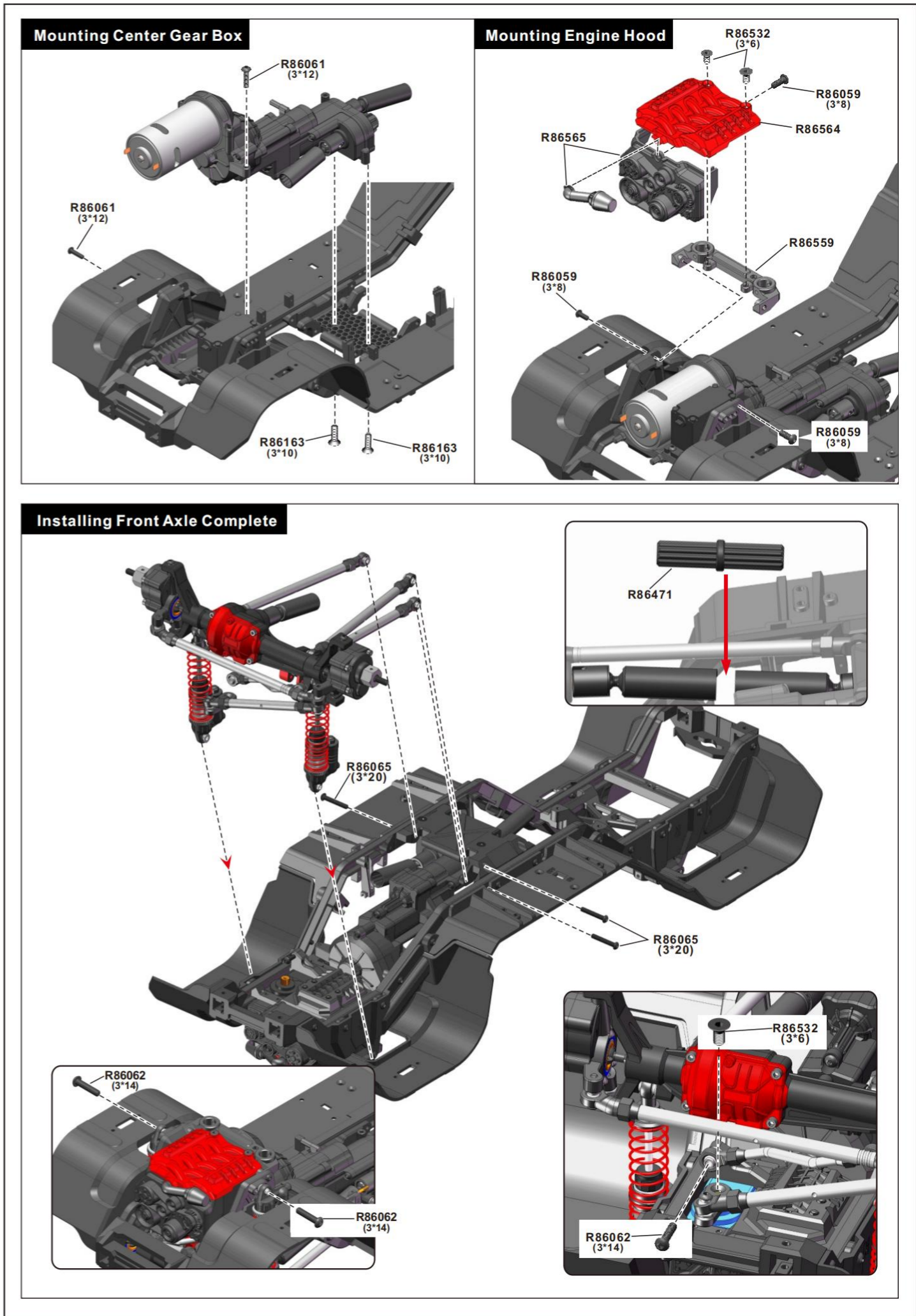
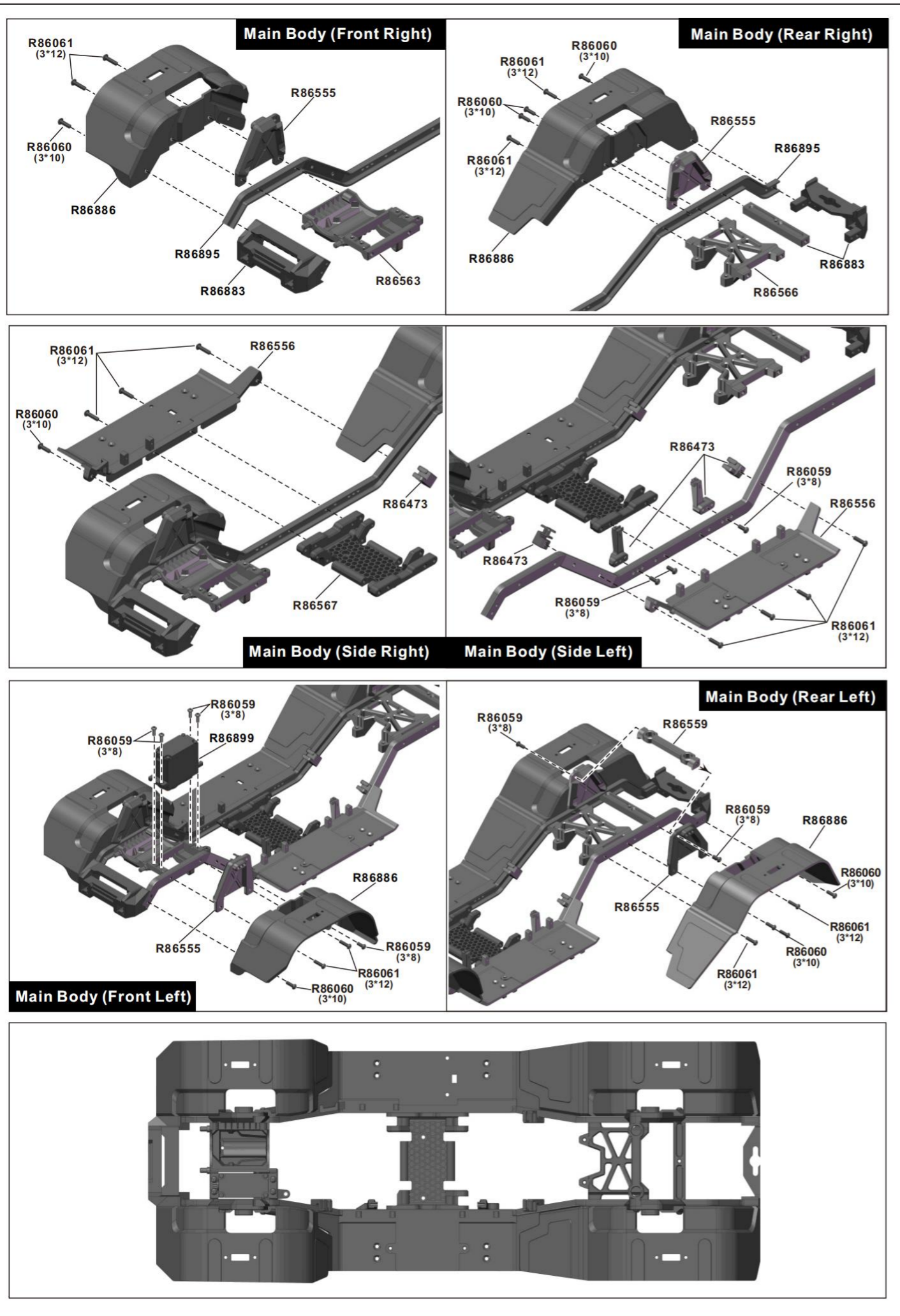

Installing Rear Axle Complete

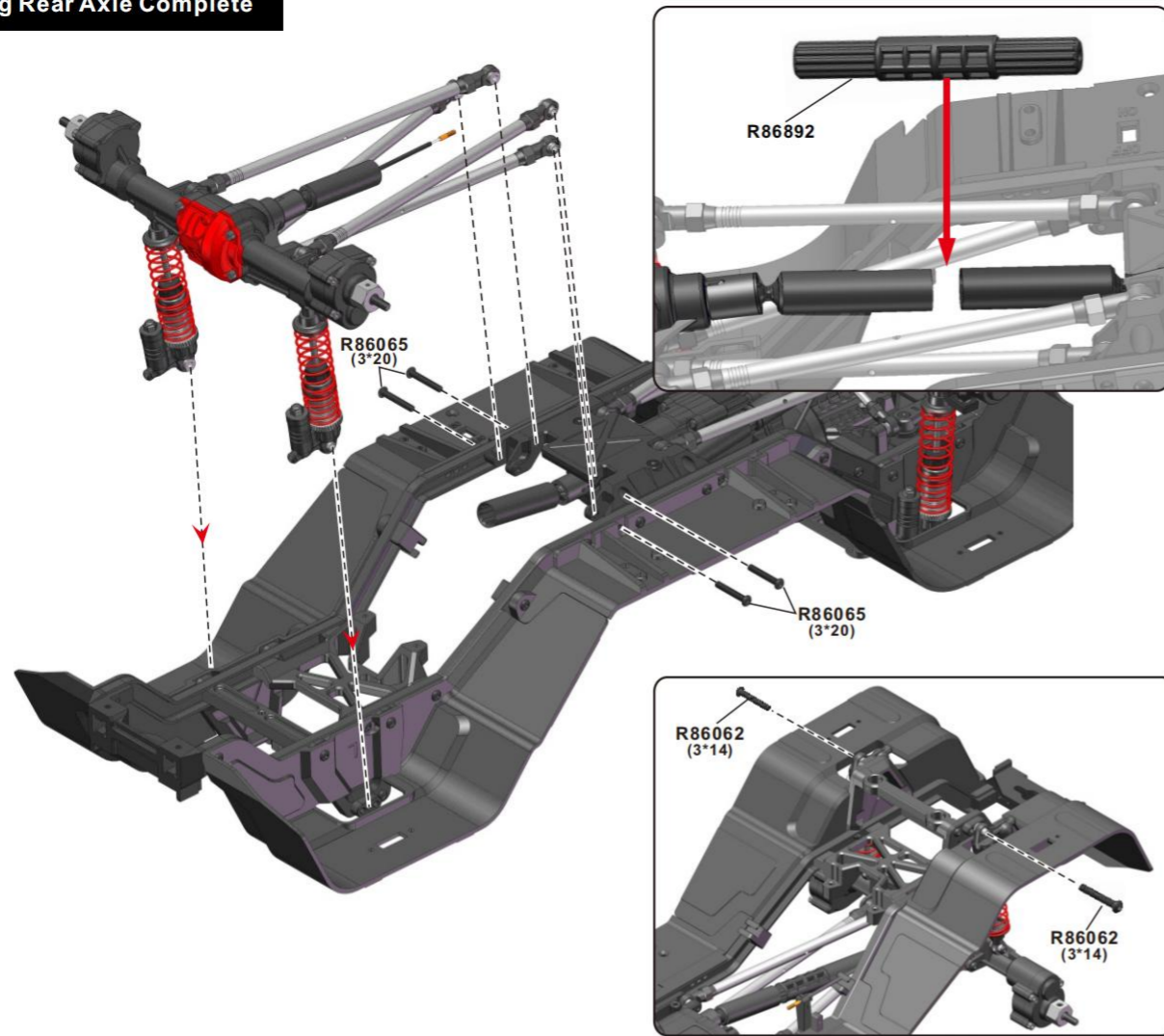

(Left)

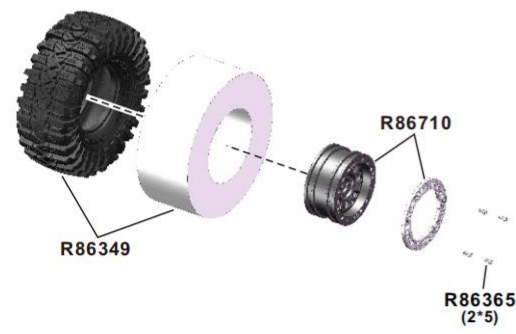

(Right)



Installing Wheel Complet To Vehicle

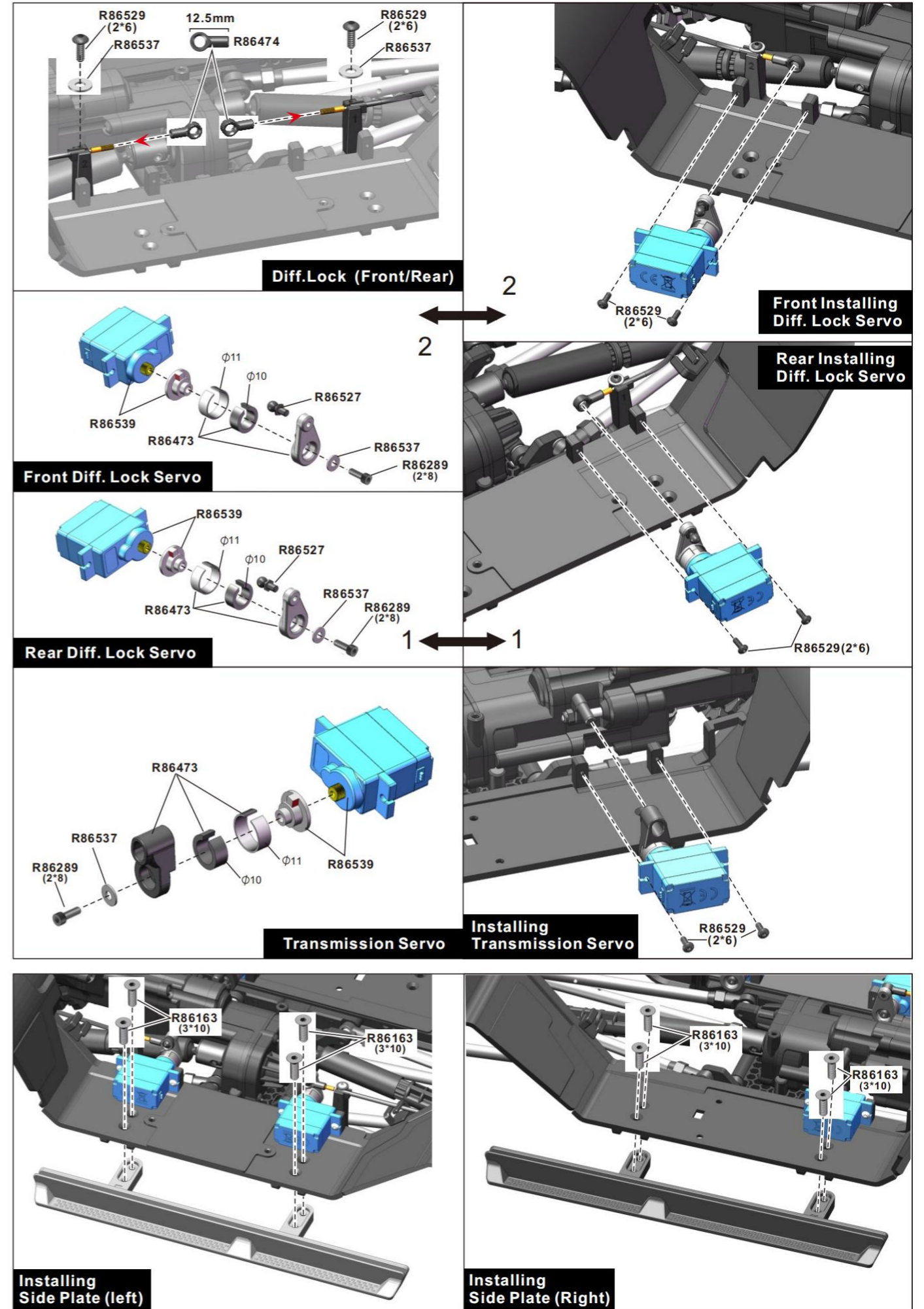
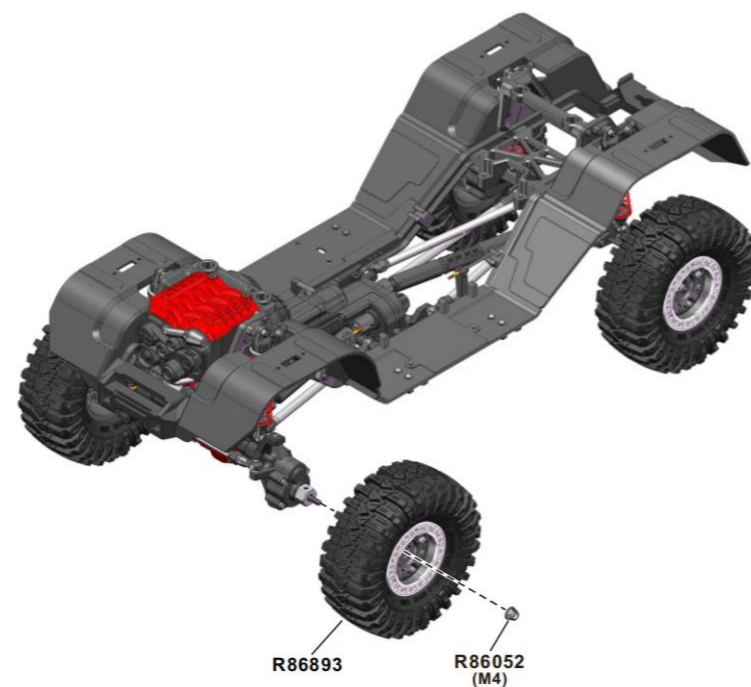

Front Bumper Assembly

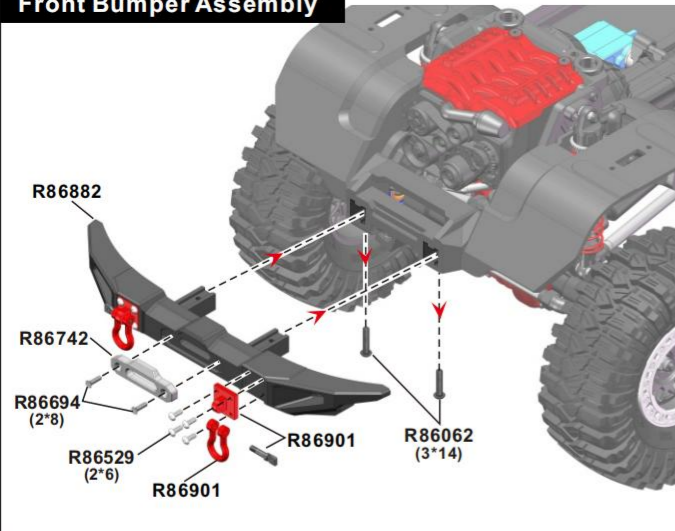

Rear Bumper Assembly

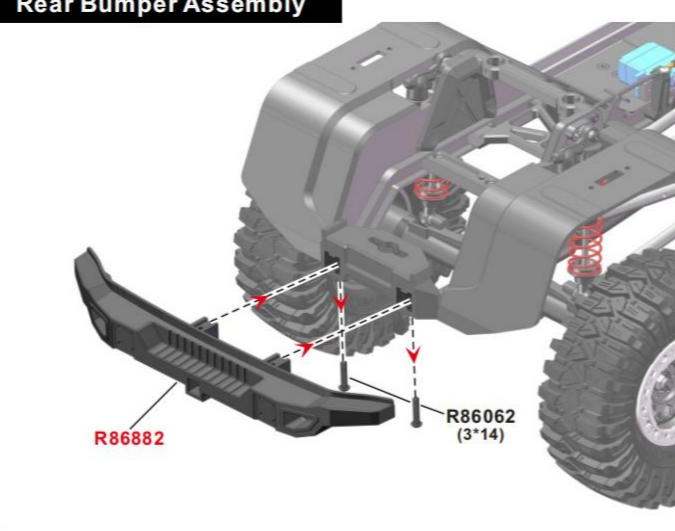

Installing Battery Holder

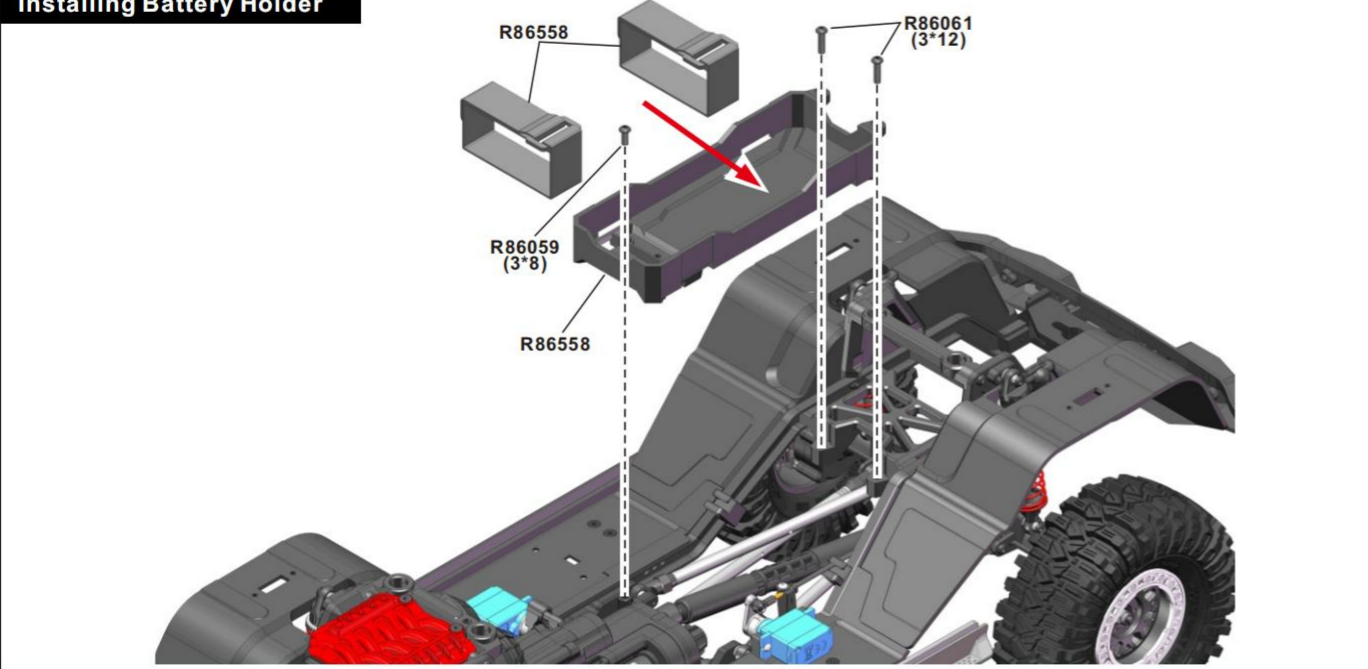

Installing ESC/Receiver

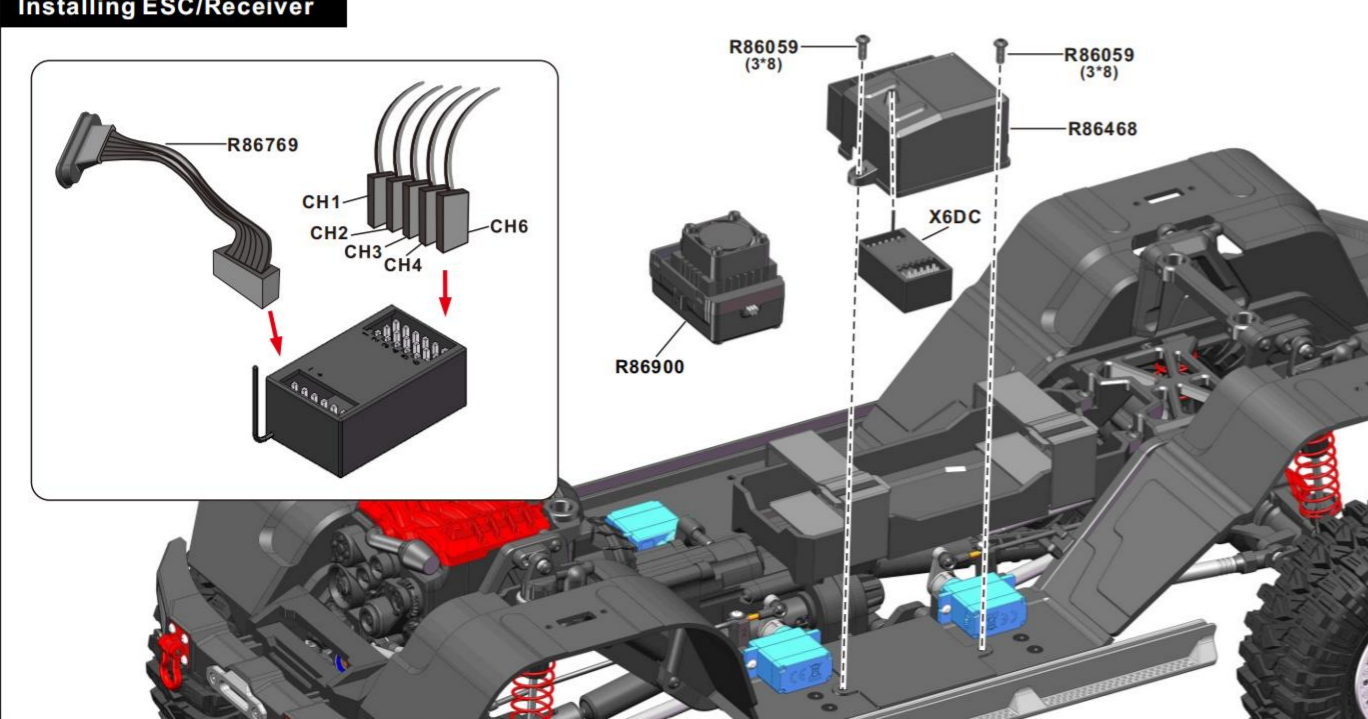

Body Assembly-1

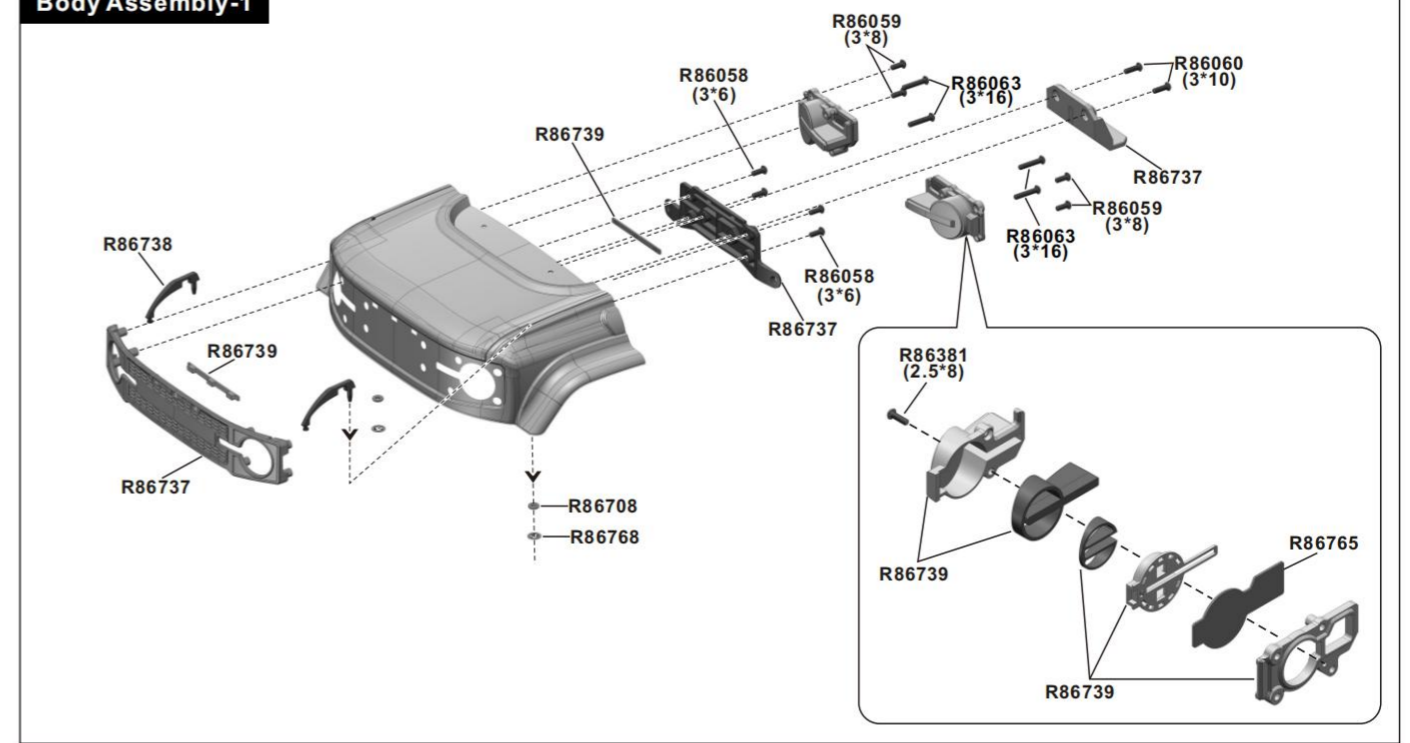

Body Assembly-2

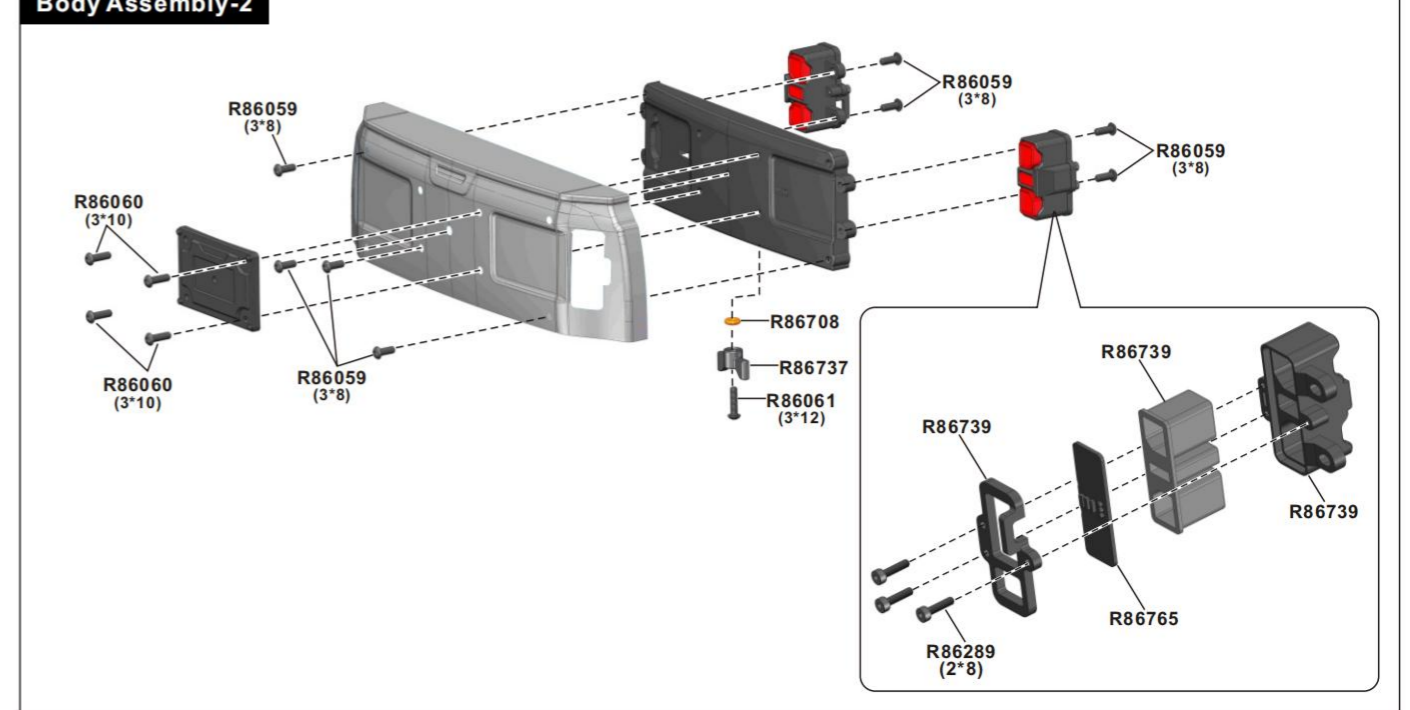

Body Assembly-3

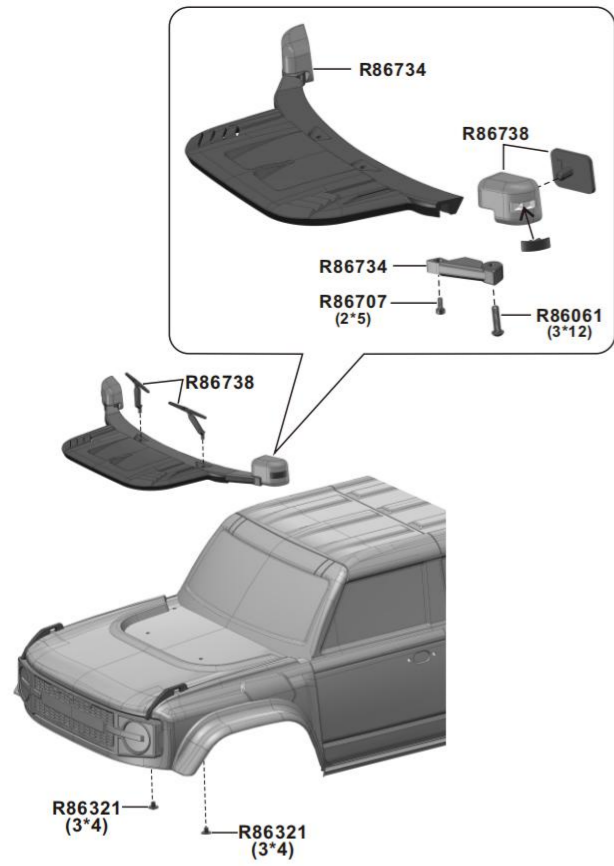

Body Assembly-4

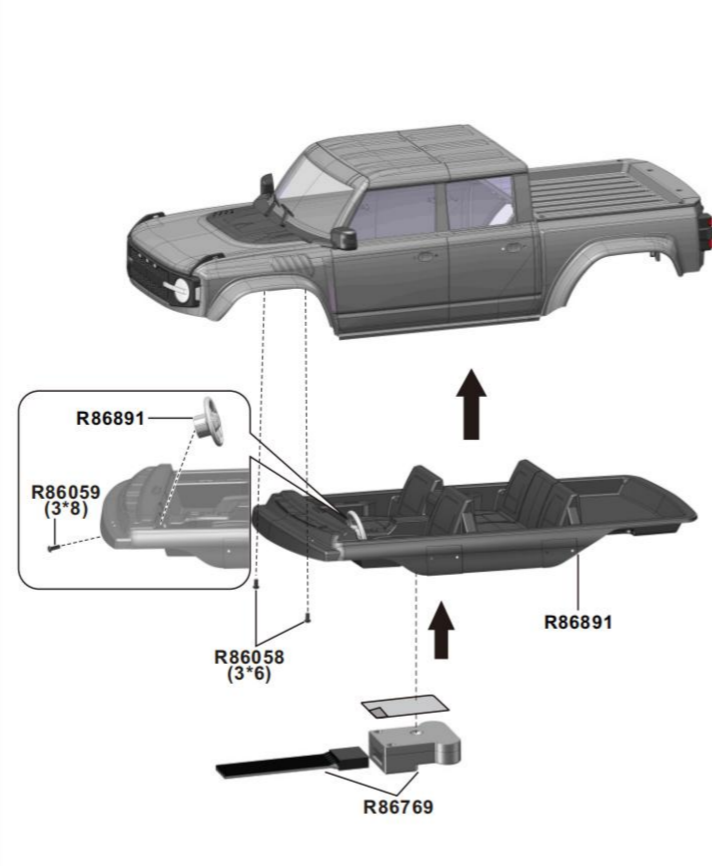

Body Assembly-5

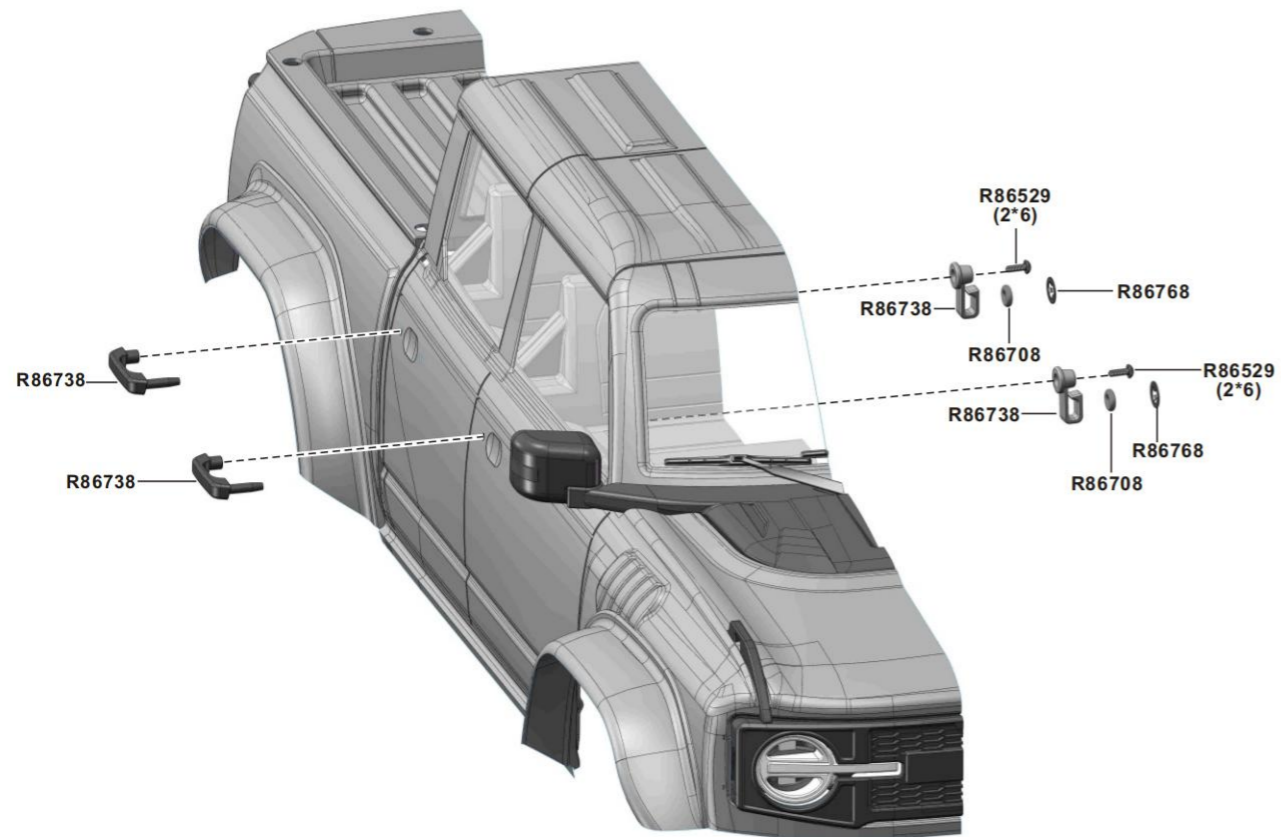



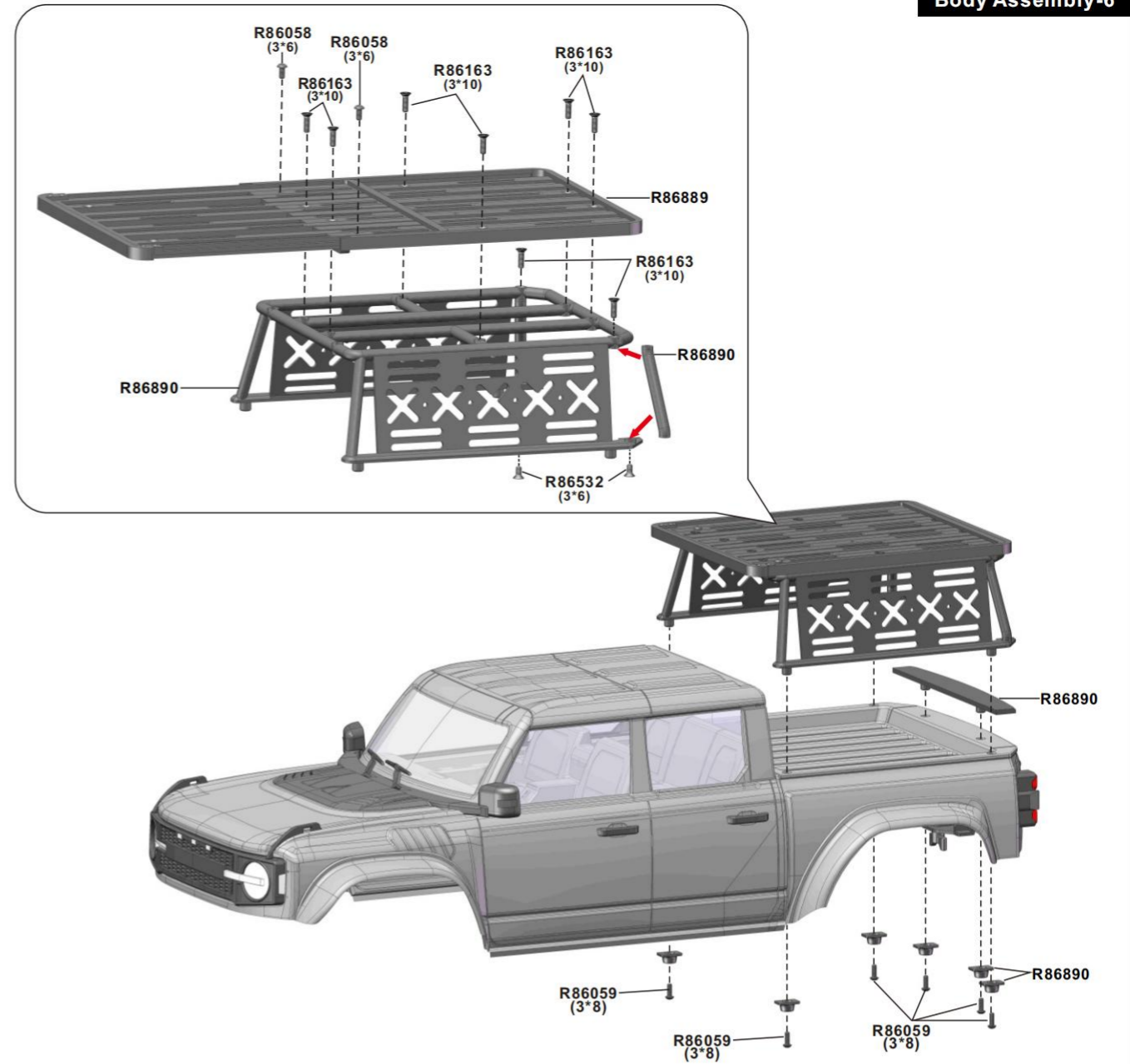



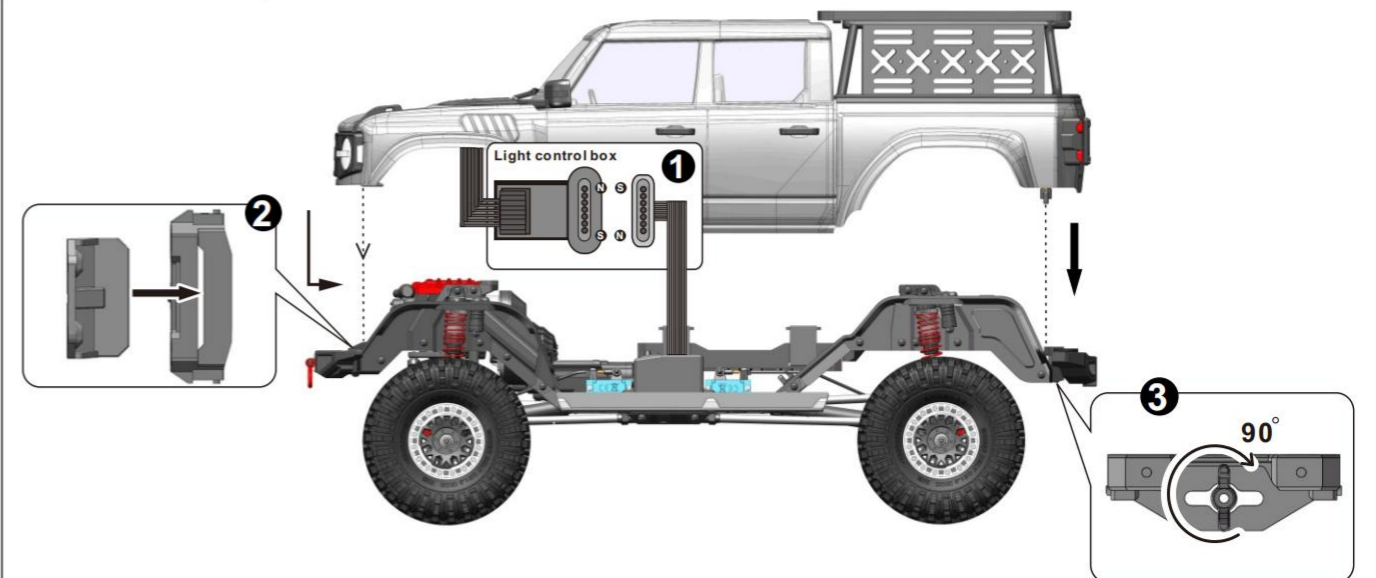







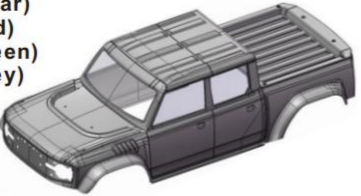

































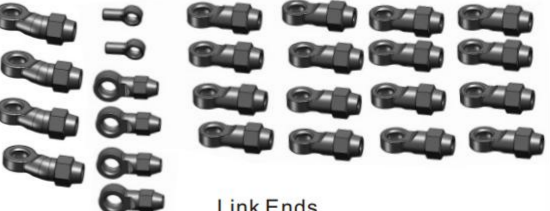







Body Assembly-6

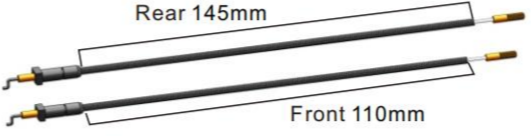

Body Assembly-7



Spare Part				
R86882  Front/Rear Bumper	R86883  Bumper Mount	R86884  (electroplate) Front Gear Box Lid	R86885  (electroplate) Rear Gear Box Lid	R86886  Baffle A(L/R)
R86887  Foot Pedal	PC Body+Sticker  R86888-0(Clear) R86888-1(Red) R86888-2(Green) R86888-3(Grey)		Pre-Assembled PC Body  P86489-1(Red) P86489-2(Green) P86489-3(Grey)	
R86889  Tail Plate	R86890  Roof Rack	R86891  PVC Cockpit+Sticker	R86892  Rear Driveshaft 41.5mm	R86893  Wheel Complete L/R
R86349  Tire W/Foam	R86710  Wheel Rim(Matte Silver)	R86548  Front Housing	R86549  Rear Housing	R86550  Steering HubCarriers L R
R86563  Servo Mount	R86564  Motor Cover Upper	R86565  Motor Cover Front	R86566  Caster Mount	R86567  Chassis Mount
R86551  Transmission Housing Lid	R86468  Receiver Box	R86469  Lock Diff Button	R86470  Differential Box	R86471  Front Driveshaft 35.5mm
R86555  Shock Plate(L/R)	R86556  Baffle B(L/R)	R86558  Battery Tray	R86559  Body Mount(F/R)	R86475  Shock Absorbers

Spare Part				
R86488  Tank	R86560  Transmission Box A Motor Mount R L	R86561  Transmission Box B		
R86734  Engine Cover Kit	R86473  Dig Servo Parts φ10 φ11	R86474  Link Ends		
R86742  Winch Mount	R86738  Body Assembled Part	R86739  Bodyshell Light Accessories Kit		
R86749  Crown Gear (64T)	R86737  Body Accessories	R86894  Light set		
R86895  Chassis Rails	R86491  Panhard Bar Link	R86492  Link 72.5mm	R86493  Link 100mm	
R86896  Front/Rear Lock Diff Line Rear 145mm Front 110mm	R86494  Link 108mm	R86496  Link 113mm	R86897  Link 140.5mm	
R86898  Link 143mm	R86498  Diff Main Gear (40T)	R86499  Drive Gear(16T)	R86500  Diff Bevel Gear Set	R86501  Transmission Gear(9T)

Spare Part				
R86502 Transmission Gear(6T)	R86503 Transmission Gear(20T)	R86504 Transmission Gear(17T)	R86505 Transmission Gear(13T)	R86506 Transmission Slider
R86507 Gear Stick	R86509 CVD Drive shaft	R86510 Rear shaft	R86511 Driveshaft	R86512 Gear Shaft 1
R86568 Shock Shaft	R86187 Sping	R86514 Slipper Spacer/Plate	R86515 Differential Lock	R86516 Gear Shaft 2
R86517 Gear Shaft 3	R86518 Gear Shaft 4	R86519 Gear Shaft 5	R86520 Ball Bearing Ø15*Ø21*4	R86521 Ball Bearing Ø12*Ø18*4
R86522 Ball Bearing Ø10*Ø15*4	R86523 Ball Bearing Ø7*Ø14*4	R86524 Ball Bearing Ø7*Ø11*3	R86525 Ball Bearing Ø5*Ø11*4	R86526 Ball Bearing Ø4*Ø8*3
R86045 King Pin Bushing	R86527 Ball Stand O4mm	R86048 Ball Stand O5.9mm	R86052 Flange M4 Lock Nut	R86528 Nylon Nut M2.5
R86379 Button Head 2*4mm	R86058 Button Head 3*6mm	R86059 Button Head 3*8mm	R86060 Button Head 3*10mm	R86061 Button Head 3*12mm

Spare Part				
R86062 Button Head 3*14mm	R86065 Button Head 3*20mm	R86066 Button Head 3*25mm	R86529 Button Head Self-tapping 2*6mm	R86530 Step Screws 4*11.5mm
R86365 Cap Head 2*5mm(Silver)	R86071 Cap Head 2.5*8mm	R86531 Cap Head Self-tapping 2*8mm	R86532 Flat Head 3*6mm	R86694 Flat Head 2*8mm
R86072 Flat Head 2.5*10mm	R86163 Flat Head 3*10mm	R86533 Crub Screw Bolt 3*18mm	R86537 Metal Washer(2.6*6*0.5)	R86534 O Ring 2.8*1.9mm*8P O Ring 2.8*2.0mm*8P O Ring 10*1mm*4P
R86535 E-Clips-Ø2.5mm*6P E-Clips-Ø4mm*6P	R86536 Pin -2*10mm*6P Pin -2*11mm*6P Pin -2*12mm*6P	R86321 Flange Head Screws 3*4	R86569 Wheel Hex	R86539 Dig Servo 9G /7.4V
R86899 Steering Servo 30KG	R86541 Servo Horn(25T)	R86538 Motor-550/8020	X8E(GS07)-150 Radio/Receiver	X6DC Rexiever
R86769 Magnetic Adapter Cable	R86900 ESC -80A	R86508 Pinion Gear(17T)	R86901 Hook Braket	

Upgradable Optionals

R86366		P860136		P860094	
Adjustable LED Lamp		Copper Wheel Weight Set 128g			
P860087	P860091	P860092	P860065	P860066	
(COPPER)	(COPPER)	(COPPER)			
Transmission Housing Lid	Front Gear Box Lid	Rear Gear Box Lid	Wheel (AL.)	Wheel (AL.)	
R86570	P860086	P860088	P860089	P860090	
	(AL.)	(AL.)	(AL.)	(AL.)	
Wheel Rim	Steering HubCarriers	Shock Plate(L/R)	Chassis Mount	Differential Box	
P860093	R86601	R86902	R86906		
(AL.)					
Motor Mount	Antenna Pole	Drive Axle	Branch-shaped Detach Line		
R86513	R86571	R86632	R86787	R86873	
Crown Gear(64T)	Crawler Battery (7.4V6200mAh/Plug:T)	Crawler Battery (11.1V4000mAh/Plug:T)	Fusion Brushless System 2-in-1(1800KV)	Steering Servo 35KG	
R86621					



PRODUCT QUALIFICATION CERTIFICATION

Remote control models are specialized and high-value products. If you identify any quality defects upon receipt, please do not use the product and contact the seller immediately to arrange a replacement or return. Please note that we cannot provide any after-sales guarantee for damages which are caused by improper use.

The product conforms to technical requirements of export safety regulations.

Factory Address: Huang Jiang Town, Dong Guan City, Guang Dong Province, China

Website: www.RGT-RACING.Com

Production Date: refer to packing instruction