



USER MANUAL

OFF-ROAD CRAWLER

NO.EX86190



ROCK CRAWLER



Notes:

- Read and understand the instructions carefully before operating or assembling your racing model.
- Specifications are subject to change without prior notice, and actual received model may vary from the images and/or descriptions in this manual.

Remote control models are specialized and high-value products. If you identify any quality defects upon receipt, please do not use the product and contact the seller immediately to arrange a replacement or return. Please note that we cannot provide any after-sales guarantee for damages which are caused by improper use.

The product conforms to technical requirements of export safety regulations.



Please read and follow all the instructions in the manual before use.

MADE IN CHINA

Factory Address: Huang Jiang Town, Dong Guan City, Guang Dong Province, China

Production Date: refer to packing instruction



Introduction

We would like to welcome you to the world of remote control cars. What are RC cars? The simple answer is that they are radio controlled cars that respond precisely to your command. The more complete answer is that they can be a great addition to your lifestyle. RC car building and racing teach valuable mechanical and electrical skills, promote teamwork and encourage racers to test their skills with other racers from around the world. Whether you are just having fun racing your car in your backyard or racing at the world competition contest, radio controlled car racing is a great hobby.

We have been making RC products aimed at making our hobby fun and exciting with an affordable price. We are confident that your experience with our products will be positive. Of all the radio controlled models out there, no question about it, RC cars are the hardest to operate. This user manual covers a wide range of topics from nitro powered remote control cars to electrical powered remote control cars. We highly recommend that you read this user manual thoroughly and carefully before assembling and operating. Please follow all precautions and recommendations located within the manual. Be sure to retain the manual for future reference, routine maintenance, and tuning.

This product is not a toy. It is not recommended for children under 14 years old and any minor should be accompanied by an adult when operating. This product is a precision machine that requires proper assembly and setup to avoid accidents. Failure to take caution when operating this product may result in serious injury or property damage. It is the owner's responsibility to operate this product in a safe manner. Manufacturer and its distributors are not responsible in any way for any and all bodily injury(s) and/or property damage that may occur from the use of or caused by in any way of this product.

Warnings

- The product is not intended for those under 14 years of age without proper adult supervision. The product is not a toy. It is a precision machine requiring proper assembly and setup to avoid accidents and it is the responsibility of the owner to operate this product in a safe manner as it can cause serious personal injury and damage to property due to carelessness or misuse.
- Do not attempt to disassemble or modify any of the product components without the assistance of an experienced RC user.
- Only use the correct type of battery to operate. Using any wrong type of battery will damage the product and possibly make it dangerous to operate.
- The motor(s) may get hot during use. Always allow the motor 10 - 15 minutes to cool down between each operation. This will prolong the life of your product.
- Choose an appropriate operating site consisting of flat, smooth ground, and clear open field. Do not operate near buildings, high voltage cable lines, or trees to ensure safety operation. Operate in safe area only, away from other people. RC models are prone to accidents, failures, and crashes due to a variety of reasons including, lack of maintenance, user error, and radio interference. Users are responsible for their actions and damage or injury occurring during the operation.
- Do not operate in inclement weather, such as rain, wind, snow or darkness.
- The product, composed of precision electrical components, must be kept away from moisture and other contaminants. Do not allow them to get wet. Electrical damage may occur that could affect safe operation.
- You should complete a successful pre-run check of your radio equipment and the model prior to each run.
- Use replacement parts from the original manufacturer to ensure safe product operation.
- Operate this product within your ability. Do not operate under tired condition.
- After each use, always allow the battery to cool down before recharging. When charging the battery pack, do not overcharge! If batteries get hot during charging, discontinue charging immediately and disconnect the battery from the charger. Never leave battery unattended while charging. If you are unsure of how to charge this battery, please seek the advice of experienced RC users. Never let children charge the battery without adult supervision.
- Always turn on the transmitter before connecting the battery on the model. When turning off the model, always disconnect the battery first, and then turn off the transmitter. If the order is reversed, the model may become uncontrollable and cause serious damage.
- If you are in doubt about your ability to operate the model, we strongly recommend that you seek assistance from experienced RC users or join your local modeling club to gain the required knowledge and skill. As the manufacturer and distributor, we assume no liability for the use of this product.
- Before turning on your model and transmitter, please check to make sure no one else is operating under the same frequency. Frequency interference can cause your model, or other's models to crash. The guidance provided by experienced RC users will be valuable for the assembly, tuning, trimming, and actual first flight.
- Never allow batteries to run low or you might lose control of the model.
- Plastic is very susceptible to damage or deformation due to extreme heat and cold climate. Do not store the model near any source of heat such as oven or heater. Store the model indoors, in a climate-controlled, room temperature environment.
- Never shorten the receiver antenna; or this might affect the transmitting range of the radio system.
- This product is a RC hobby model, do not use for other purpose.



Safety

Pay close attention to the following symbols and their meanings. Failure to follow these warnings could cause damage, injury or death.

 **Danger** Not following these instructions may lead to serious injuries or death.

 **Warning** Not following these instructions may lead to major injuries.

 **Attention** Not following these instructions may lead to minor injuries.

 <p>Prohibited</p>	<ul style="list-style-type: none"> ■ Do not use the product at night or in bad weather like rain or thunderstorm. It can cause erratic operation or loss of control. ■ Do not use the product when visibility is limited. ■ Do not use the product on rain or snow days. Any exposure to moisture (water or snow) may cause erratic operation or loss of control. ■ Interference may cause loss of control. To ensure the safety of you and others, do not operate in the following places: <ul style="list-style-type: none"> ● Near any site where other radio control activity may occur ● Near power lines or communication broadcasting antennas ● Near people or roads ● On any body of water when passenger boats are present ■ Do not use this product when you are tired, uncomfortable, or under the influence of alcohol or drugs. Doing so may cause serious injury to yourself or others. ■ The 2.4GHz radio band is limited to the line of sight. Always keep your model in sight as a large object can block the RF signal and lead to loss of control. ■ Do not touch any part of the model that may generate heat during operation, or immediately after use. The engine, motor or speed control, may be very hot and can cause serious burns.
 <p>Mandatory</p>	<ul style="list-style-type: none"> ■ Misuse of this product may lead to serious injury or death. To ensure the safety of you and your equipment, read this manual and follow the instructions. ■ Make sure the product is properly installed in your model. Failure to do so may result in serious injury. ■ Make sure to disconnect the receiver battery before turning of the transmitter. Failure to do so may lead to unintended battery issues or an accident. ■ Ensure that all motors operate in the correct direction. If not, adjust the direction first. ■ Make sure the model stays within the radio maximum signal range to prevent loss of control during operation.

Thanks for purchasing our RC car. Since the power system of the RC model can be very dangerous, please read this manual carefully. Since we have no control over the correct use, installation, application, or maintenance of our products, we shall assume no liability for any damages, losses or costs resulting from the use of this product. Any claims arising from the operating, failure of malfunctioning etc. will be denied. We assume no liability for personal injury, consequential damages resulting from our product or our workmanship.



START GUIDE

1. Please read the manual carefully and prepare the following things before use.

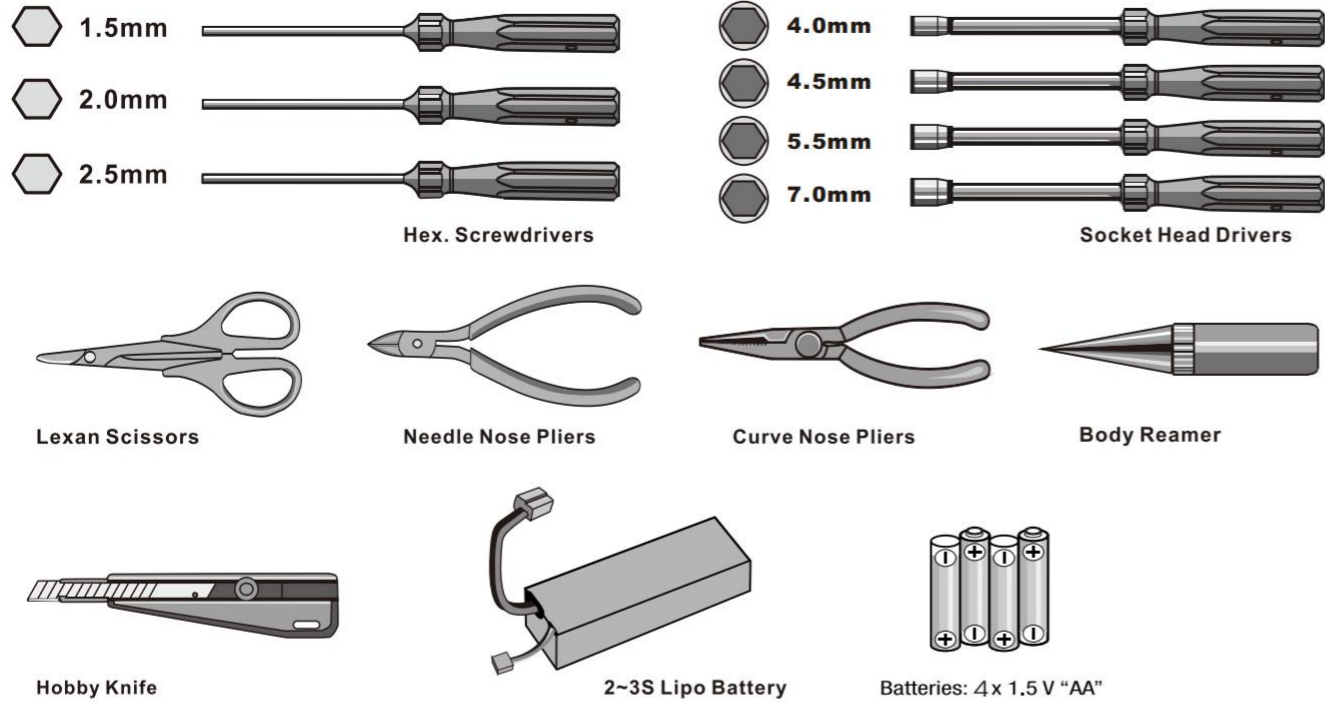

2. The items inside the box.

One car



Transmitter



3. Please check the whole product condition when open the package.

Take out the body clips from vehicle bottom, Unplug the light connector, and take out the car body.

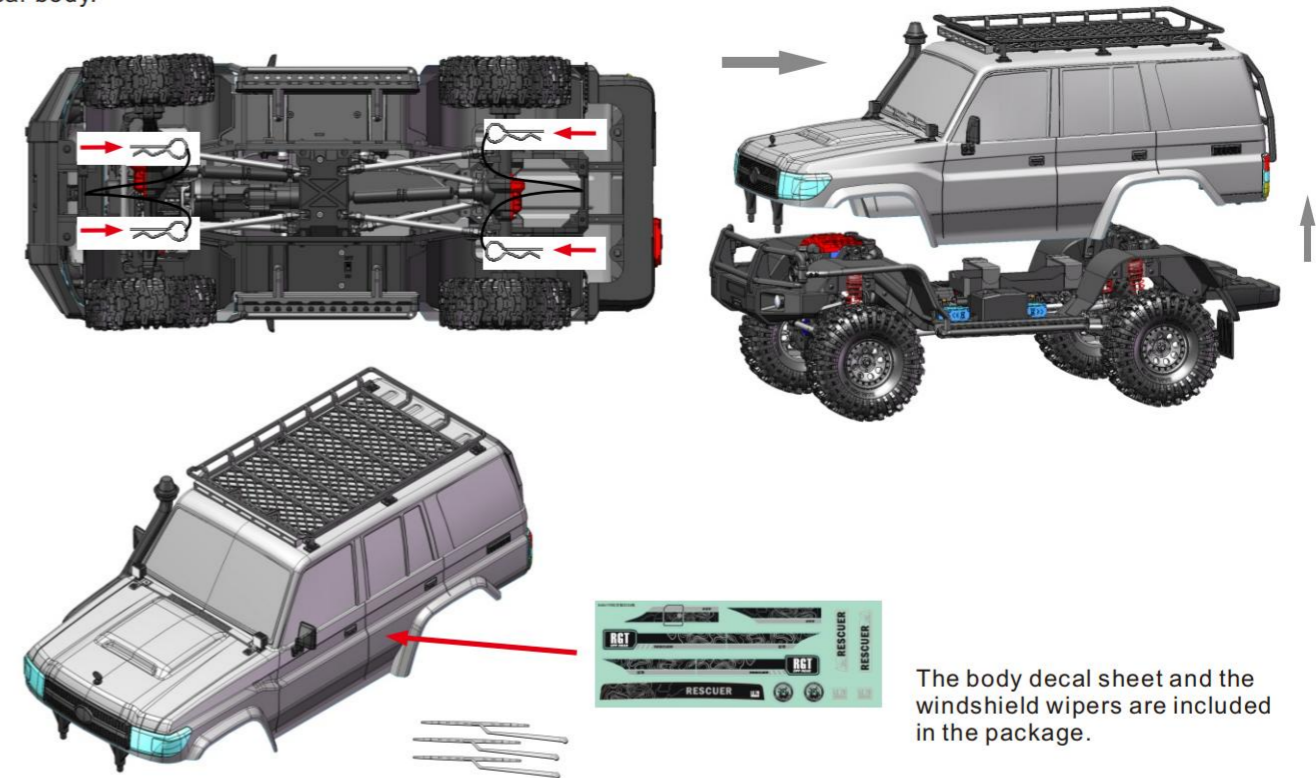

- 3-1. After each day of running, you should check your shocks for adequate fluid. If the fluid is low, or it is getting dirty, you should change the fluid in the shocks. To achieve better performance, you may also want to change the shock fluid and or the pistons.
- 3-2. Gear mesh is the clearance between the pinion and spur in an electric car or clutch bell and spur in a nitro car. It has impact on the vehicles performance. If the gear mesh is not set properly you may also damage the clutch bell and spur or the pinion gear and spur gear as soon as the vehicle starts running.
- 3-3. Please check if the screw is tight enough before use. Screw it tight (or apply the screw glue if necessary)
- 3-4. Regularly check and verify the tires are intact. No breach should be observed. Please apply the CA glue if needed.

4-1. Install Charged Batteries In Car.

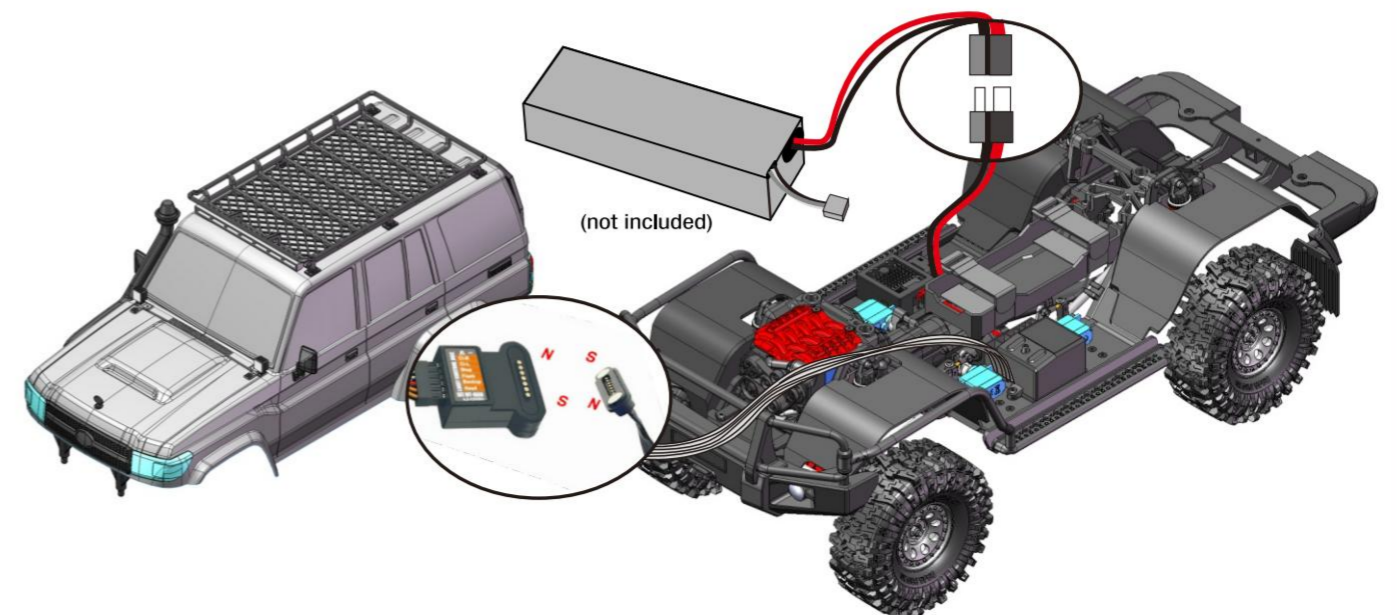

4-2. Battery Specifications for Product

WARNING:

NO battery includes in factory. Recommend?battery: 2S~3S LIPO battery or 5-9 cells NIMH battery (please match the ESC mode with the corresponding battery type)Pay attention to the battery size and plug specification when purchasing.The maximum battery measurement is 142*48*55mmJLxWxH).

This product can use the 2S or 3S Li-Po battery.

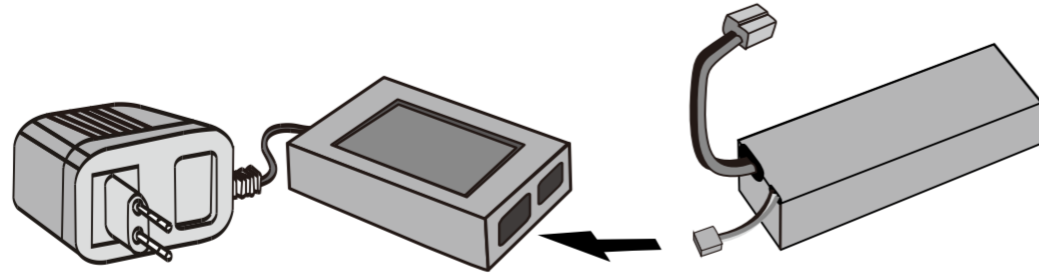

NOTICE

Please check the battery voltage before use. Please use a qualified charger to charge the newly purchased battery. (please read the charging steps in manual when necessary)

Charge the vehicle battery

- Connect charger plug with mains jack and then connect with connector of battery.
- Please be care of safety while charging, please remove charger plug from the mains jack once finish charging. will be over heat if it is too long to be charging or incorrect charging way. must stop charging if over 45 degree for the battery temperature.
- Do not charge for battery at once when you take it away from your car. Please make sure battery in cool condition before recharge battery to keep battery performance running well and get a longer use life.

Lithium Polymer (LiPo) Battery Warnings

- Never charge a lithium polymer battery with a charger designed for NiCd, NiMH, or any other type of battery chemistry. Use ONLY charger designed for LiPo battery.
- Do not leave LiPo battery unattended during charging.
- Do not overcharge the battery.
- Always place the battery on a heat resistant surface alone when charging.
- Always put the LiPo battery inside a charging protection conatiner while charging.
- Do not allow LiPo cells to overheat at any time. Cells which reach greater than 140 Fahrenheit (60°C) will usually become damaged and will catch fire.
- Do not charge LiPo cells on or near combustibile materials including paper, plastic, carpets, vinyl, leather, and wood. inside an R/C model or full size automobile.
- Do not discharge LiPo; doing so will damage the battery.
- Do not expose LiPo cell to water or moisture at any time.
- Do not store battery near open flame or heater.
- Do not assemble LiPo cells or pre-assembled packs together with other LiPo cells or packs.
- Always store LiPo battery in a secure location away from children.
- Always remove the LiPo battery if model is involved in any kind of crash. Carefully inspect the battery and connectors for even the smallest damage. **CAUTION: cells may be hot!**
- Do not allow the electrolyte to get into eyes or on skin. Wash affected areas immediately if they come into contact with electrolyte. Do not alter or modify connectors or wires of a LiPo battery pack.
- Always inspect the condition of the battery before charging and operating.
- Do not short circuit the LiPo battery.
- Do not have contact with a leaky/damaged battery directly.
- Do not charge battery out of recommended temperature range(0°C -45°C)

4-3. Scheme of installation

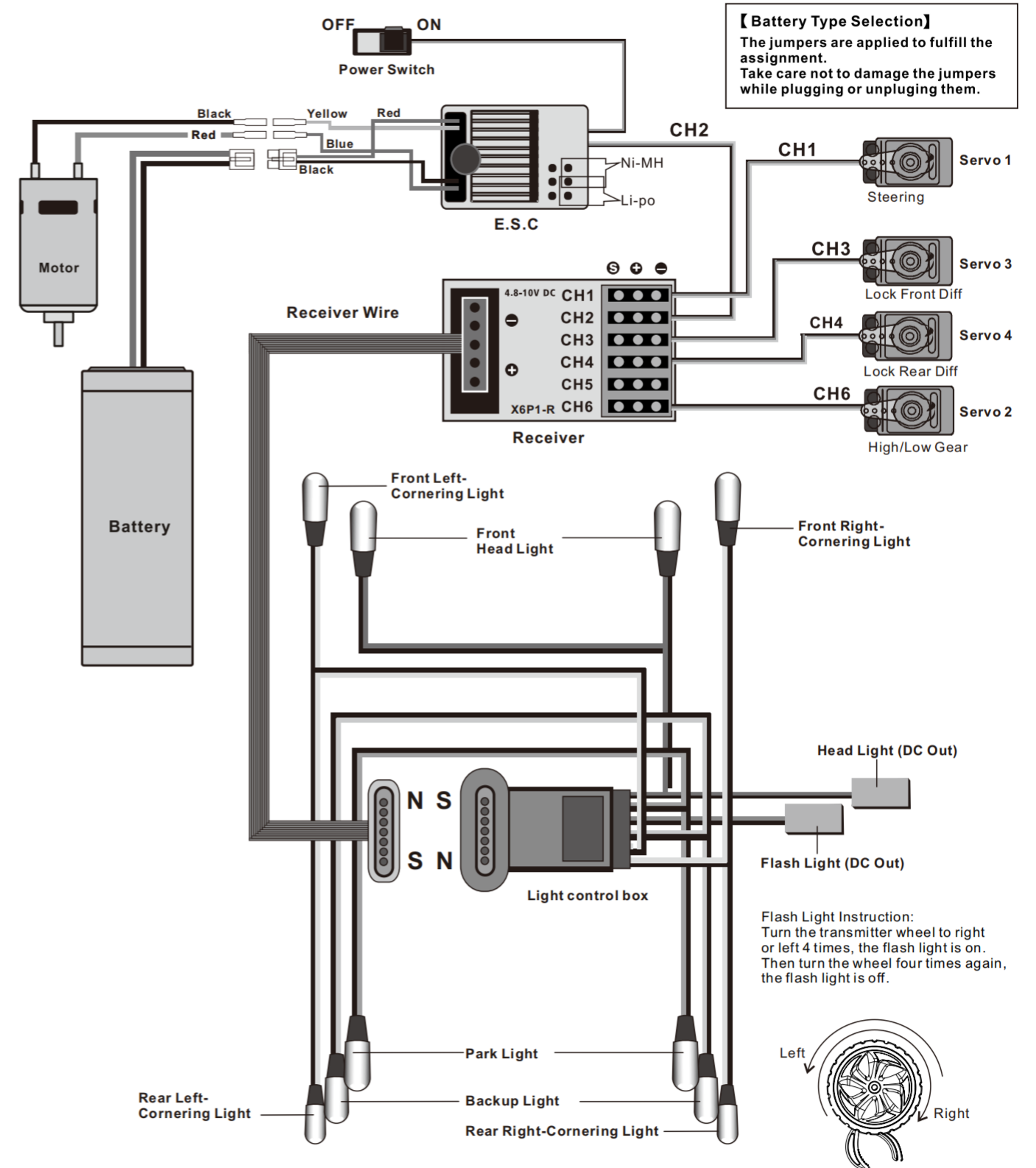

5-1. 2.4GHZ Radio System

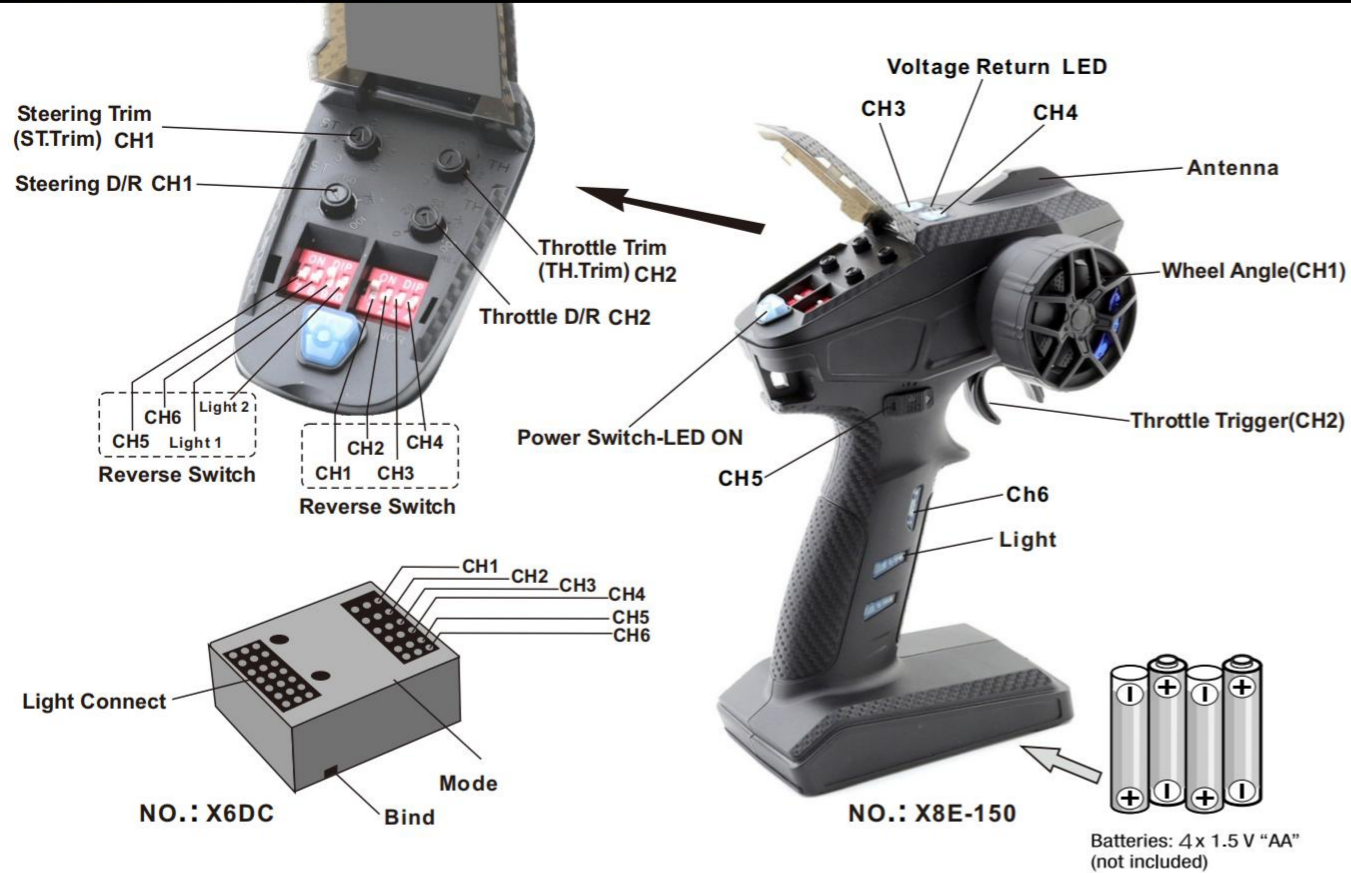

Install The Transmitter Batteries:

1. Open the battery compartment cover.
2. Insert 4 AA fully charged batteries or 2S Li-Po batteries in correct polarity.
(No response if battery polarity reversed.)
3. Close battery compartment cover.

Binding Process:

1. Press receiver button, LED indicator fast flashing means entering into binding mode, the receiver will automatically looking for the nearest transmitter signal.
2. The indicator will always ON after successful bond.

5-2. Transmitter Steering Trim and Throttle Trim

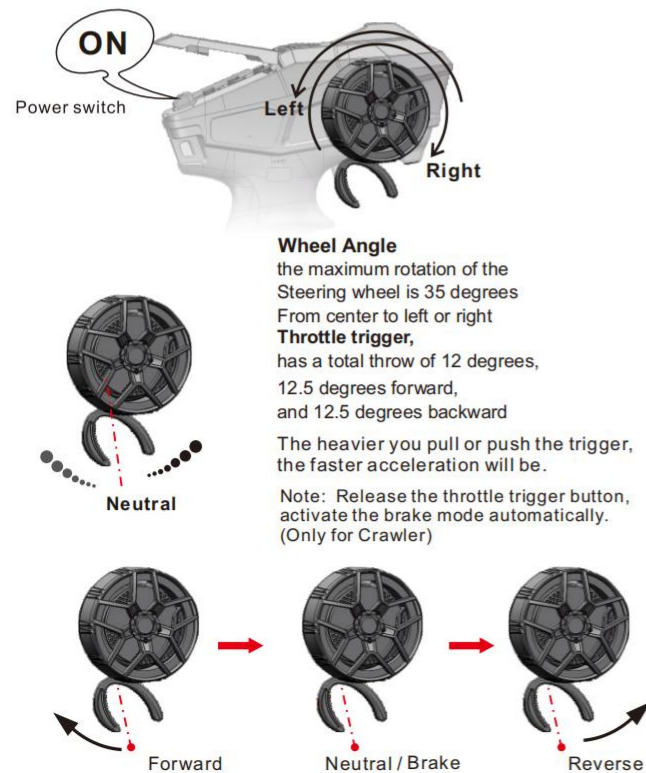

1. Move the control wheel to the left, vehicle turns left.
2. Do not move the control wheel, the front wheels are aligned and the vehicle goes straight in line.
3. Move the control wheel to the right, vehicle turns right.

Note

Place the Vehicle on the stand with four wheels off ground as shown.

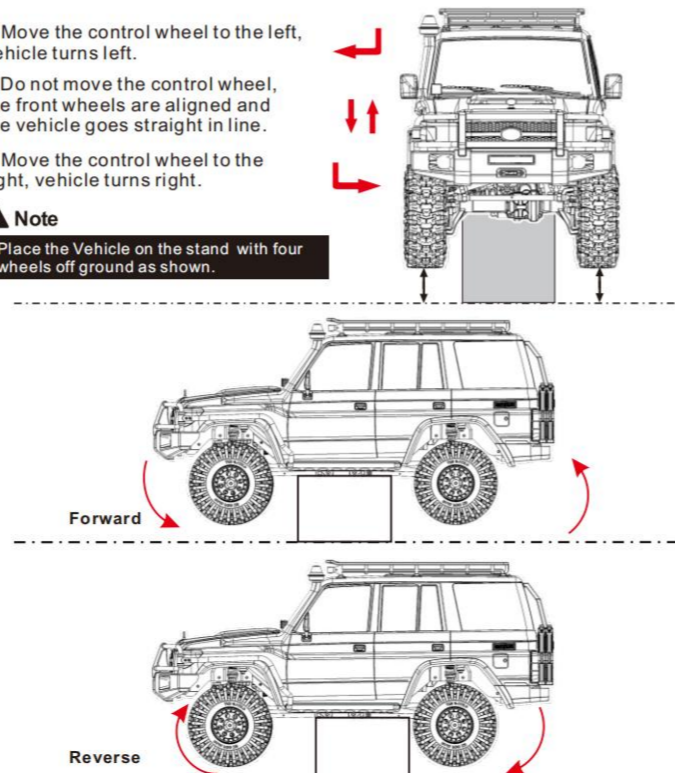

5-3. Transmitter Steering and Throttle Instruction

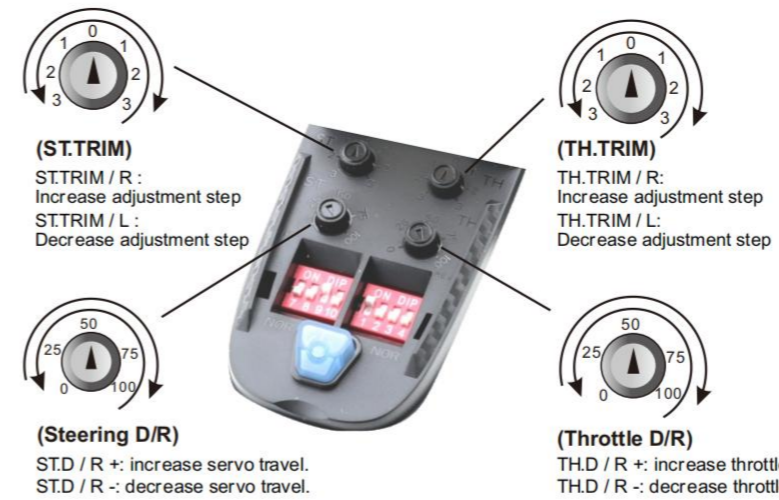

Note:

- Please trim the Throttle Trim (TH. Trim) until the vehicle stops in case the vehicle goes forwards or backwards itself just after it is turned on.
- If the front wheels are not aligned, please trim "steering trim" (ST.TRIM) until they are aligned.
- The ST.TRIM is the trims for Ch1 (steering), You can trim the Steering Trim until it fulfills your desired steering angles.
- ST.D / R is for servo travel adjustment, which can be multiplexed as CH2 (throttle).

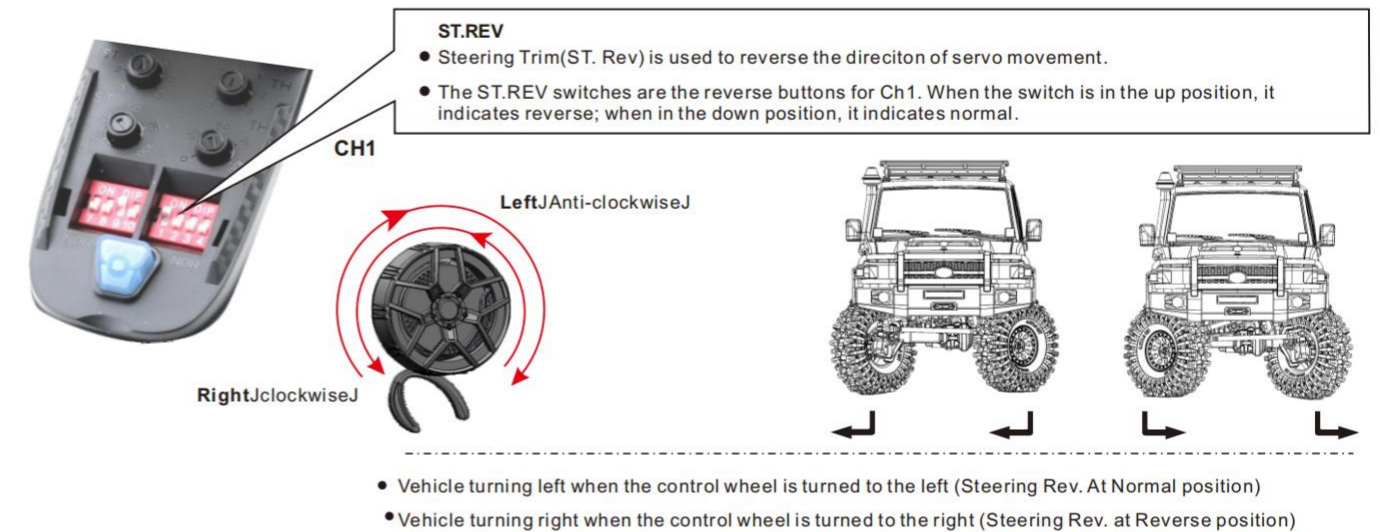

ST.REV

- Steering Trim (ST. Rev) is used to reverse the direction of servo movement.
- The ST.REV switches are the reverse buttons for Ch1. When the switch is in the up position, it indicates reverse; when in the down position, it indicates normal.

Channel Reverse

TH.REV

- The Throttle Rev. is used to reverse the direction of motor rotation.
- The TH.REV switches are the reverse buttons for CH2. When the switch is in the up position, it indicates reverse; when in the down position, it indicates normal.

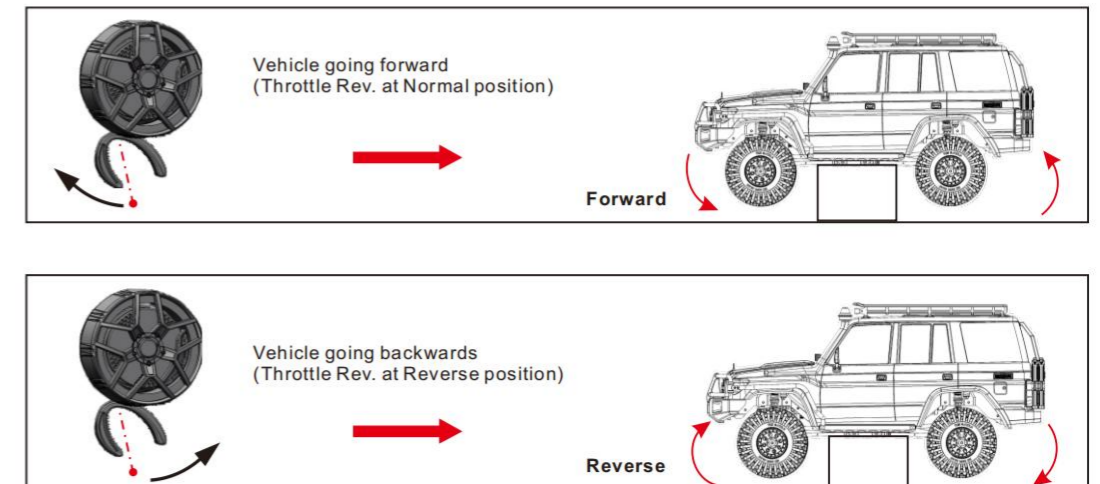

5-4. Light Control Usage



As shown in the picture: press the button, press one time, the light is on; press two times, the light flashes; press it again, the light is off.

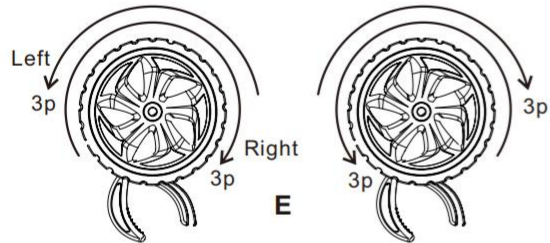
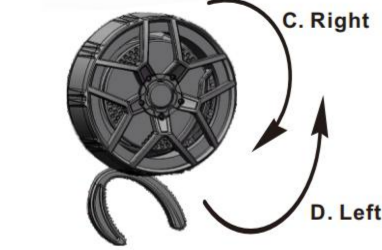
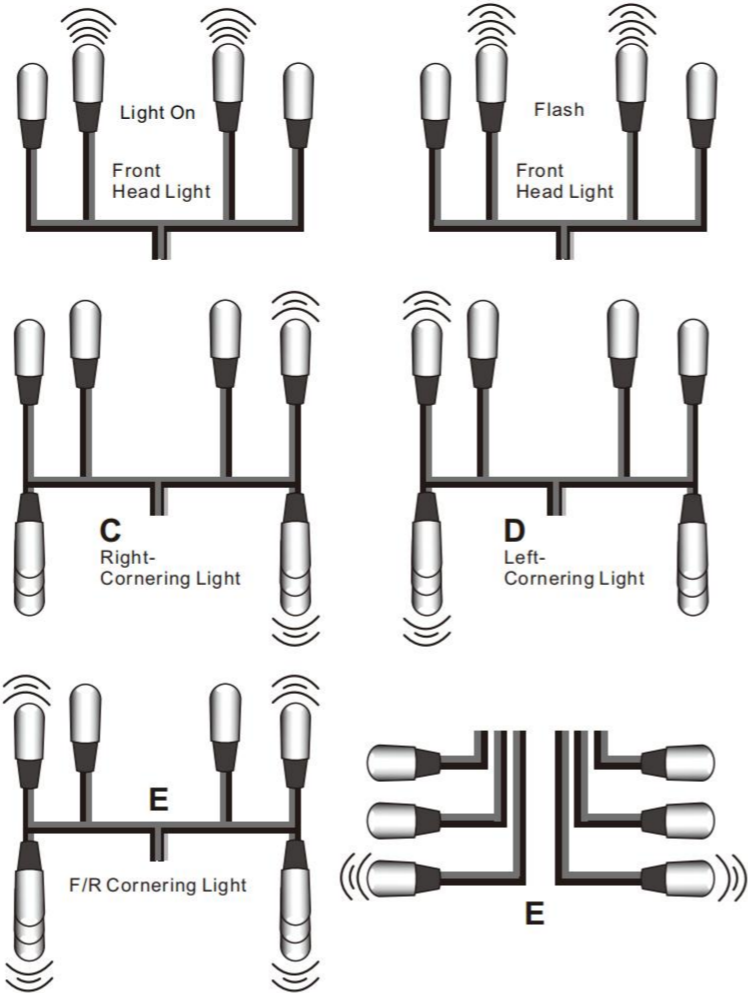

E. Turn the transmitter wheel left or right for three times, the emergency light flash is on. Turn three times again, the flash function is off.

F. Power Switch (OFF/ON)

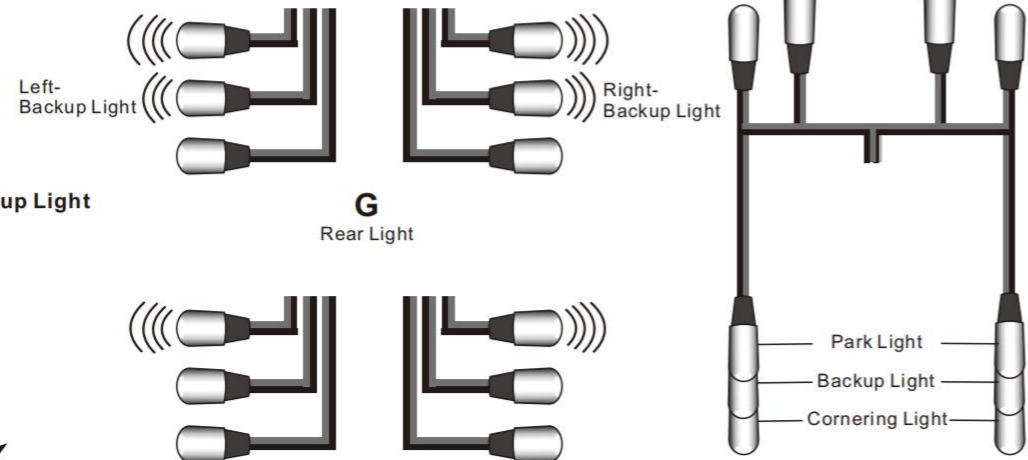
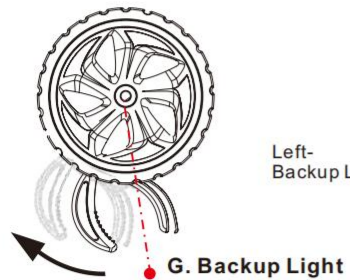
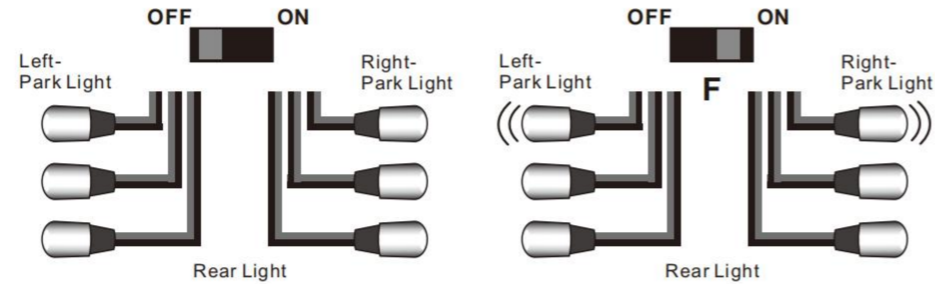
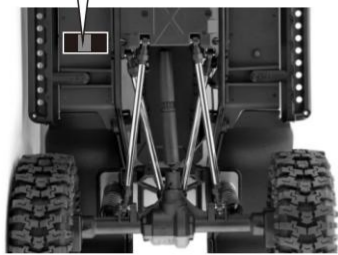

5-5. Operating the Lock Differentials

The switch on top of the transmitter operates CH3/CH4 the front and rear differential locking mechanism. The differentials can be locked or unlocked at any time during most driving conditions. If the model is stuck and there is wheelspin on a single wheel (one side of an unlocked differential is freewheeling), then release the throttle and allow the wheels to stop before locking the differential. Apply throttle slowly until the differentials fully engage or disengage.

! The front and rear diff lock is locked in factory. Ensure the vehicle in static or slow driving to avoid gear sweeping when conversion operation on the front and rear diff lock.

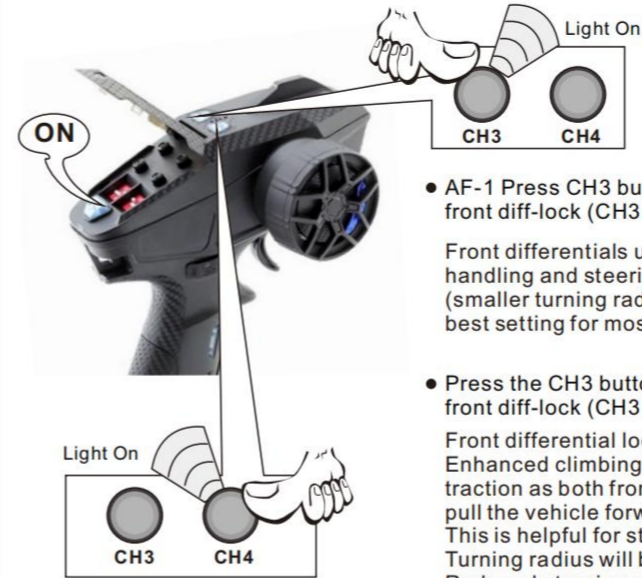

• AF-1 Press CH3 button, unlock the front diff-lock (CH3 button is on.)
Front differentials unlocked. Best handling and steering performance (smaller turning radius). This is the best setting for most of your driving.

• Press the CH3 button again, lock the front diff-lock (CH3 button is off.)
Front differential locked. Enhanced climbing ability and traction as both front tires work to pull the vehicle forward. This is helpful for steep inclines. Turning radius will be decreased. Reduced steering performance.

- AR-2 Press CH4 button, unlock the rear diff-lock (CH4 button is on.)
- Press the CH4 button again, lock the rear diff-lock (CH4 button is off.)
- AB-3 Press CH3 and CH4, unlock the front and rear diff-lock. (the button is on)
- Press CH3 and CH4 again, lock the front and rear diff-lock. (the button is off)

Both differentials locked. Maximum climbing ability and traction. Reduced steering performance. On surfaces with good traction, it is normal for the truck to appear to alternately bind and slip the tires when attempting tight turns with the differentials fully locked.

Locked differentials can be used at any time, but unlocking the differentials greatly improves vehicle handling during high-speed driving

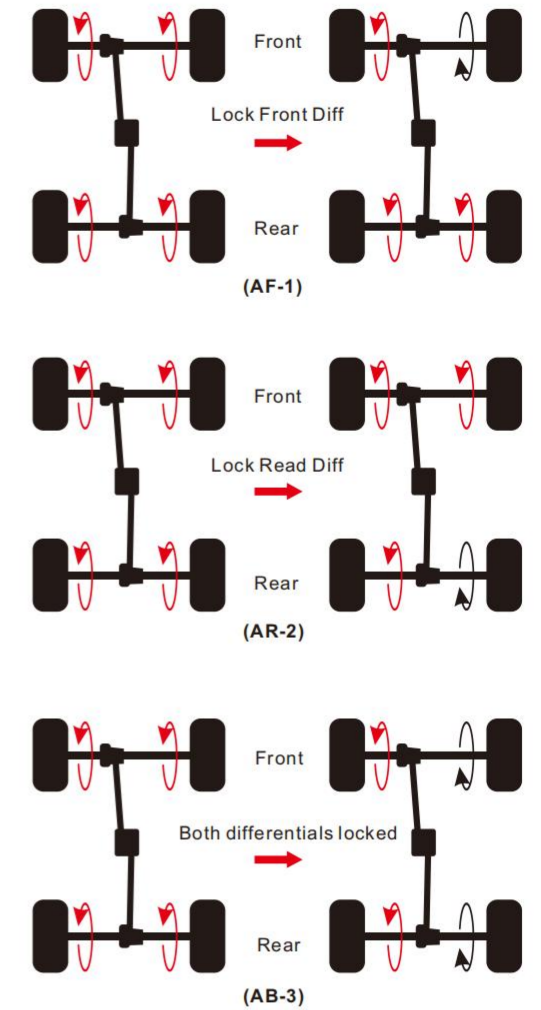

5-6. Shifting the High-Low Transmission

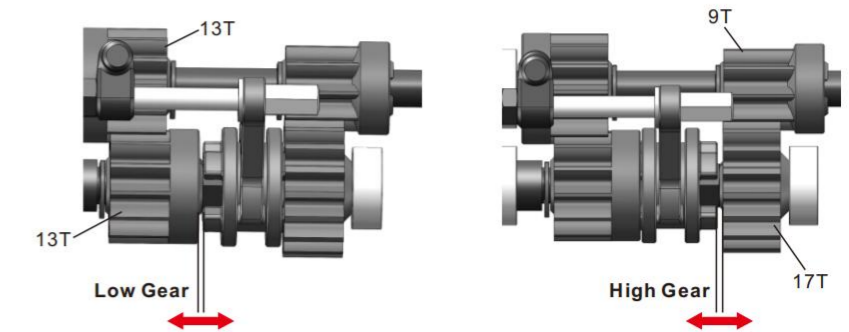

- Press CH6 button, the button light is on, switch to high-speed gear
- Press CH6 button again, the button light is off, switch to low-speed gear

! Please stop or slow down the vehicle when shifting gear, from low-speed to high-speed or from high-speed to low-speed, in order to make the shift operation more smoother and protect the gear.

6. WP-880-Dual Brushed RTR

Model	WP-880-Dual Brushed RTR
Cont./Peak Current	80A/400A
Motor Type	Brushed Motor (540/550/775 size motors)
Applications	1/10th & 1/8th On-roads/ Buggies/Trucks/Monster Trucks/Rock Crawlers & Some Boats
Motor Limit	Brushed Motor Limit with 2S LiPo/6S NiMH: $\geq 12T$ or $RPM < 30000@7.4V$ (540/550 size motors) Brushed Motor Limit with 3S LiPo/9S NiMH: $\geq 18T$ or $RPM < 20000@7.4V$ (540/550 size motors) Brushed Motor Limit with 4S LiPo/12S NiMH: $\geq 24T$ or $RPM < 15000@7.4V$ (540/550 size motors)
LiPo/NiMH Cells	2-4S LiPo or 5-12S NiMH
BEC Output	7.4V@4A (Switch-mode)
Size/Weight (w./ Wires)	45.9mm(L)*34.7mm(W)*26.5mm(H)/ 75g
Programming Port	Separate Port

6-1. Programmable Items

Those "White text with Black background" options are the factory default settings

Programmable Items	Option 1	Option 2	Option 3	Option 4	Option 5	Option 6	Option 7	Option 8	Option 9
Running Mode	Fwd/Brk	Fwd/Rev /Brk	Fwd/Rev						
Battery Type	LiPo	NiMH							
Cutoff Voltage	Disabled	Auto(Low)	Auto (Medium)	Auto (High)					
Initial Start Force	0%	2%	4%	6%	8%	10%	12%	14%	16%
Max. Forward Force	25%	50%	75%	100%					
Max. Reverse Force	25%	50%	75%	100%					
Max. Brake Force	0%	12.5%	25%	37.5%	50%	62.5%	75%	87.5%	100%
Initial Brake Force	0%	6.25%	12.5%	18.75%	25%	31.25%	37.5%	43.75%	50%
Drag Brake	0%	5%	10%	50%	60%	70%	80%	90%	100%
Drag Brake Rate	Level 1	Level 2	Level 3	Level 4	Level 5	Level 6	Level 7	Level 8	Level 9
Neutral Range	0.02ms	0.03ms	0.04ms	0.05ms	0.06ms	0.07ms	0.08ms	0.10ms	0.12ms
Start Mode/Punch	Level 1	Level 2	Level 3	Level 4	Level 5	Level 6	Level 7	Level 8	Level 9
PWM Frequency	1K	2K	4K	8K	16K				
BEC Voltage	7.4V								
Freewheeling/ DEO	Enabled	Disabled							

1).Running Mode

Option 1: Forward with Brake

It's a racing mode. It has only forward and brake functions.

Option 2: Forward/ Reverse with Brake

This option is known to be the "training" mode with "Fwd/Rev/Brk" functions. We have adopted the "DOUBLE-CLICK" method, that is your vehicle only brakes on the 1st time you push the throttle trigger forward (brake) (1st push). The motor stops when you quickly release the throttle trigger and then re-push the trigger quickly (2nd push), only then the vehicle will reverse. The reverse function will not work if your car does not come to a complete stop. The vehicle only reverses after the motor stops. This method is for preventing vehicle from being accidentally reversed.

Option 3: Forward and Reverse

This mode is often used by special vehicles (rock crawler). It adopts the "SINGLE-CLICK" method. The vehicle will reverse immediately when you push the throttle trigger forward (brake).

2).Battery Type

This item provides two options: **LiPo & NiMH**, please select as per your battery and set the cutoff voltage accordingly.

3).Cutoff Voltage

This item is mainly for preventing the LiPo battery from irreversible damage due to over discharge. The ESC monitors the battery voltage all the time, it will immediately cut off the output when the voltage goes below the cutoff threshold. The Red LED will flash " , , " when the low-voltage cutoff protection is activated. When the "Battery Type" is set to "LiPo", the voltage corresponds to "Auto (Low)/Auto (Medium)/Auto (High) is 3.0V/3.2V/3.4V per cell; when the "Battery Type" is set to "NiMH", the voltage corresponds to "Auto (Low)/Auto (Medium)/Auto (High) is 4.5V/5.0V/5.5V (for the whole NiMH pack).

4).Initial Start Force

It's the initial force when you pull the throttle trigger from neutral position toward non-throttle throttle position. A suitable start force can effectively prevent vehicle from sliding when you apply a low throttle amount.

5).Max. Forward Force

It's the force when throttle trigger is at the full throttle position. It's adjustable among 25%, 50%, 75% and 100% (by default). You can lower down the value for better driving feel/control when you drive a crawler (simulation model) over difficult terrains (and don't have any requirement against the maximum speed).

6).Max. Reverse Force

Different reverse amount will bring different reversing speed. For the safety of your vehicle, we recommend using a low amount.

7).Max. Brake Force

The ESC provides proportional braking function; the braking effect is decided by the position of the throttle trigger. It sets what percentage of available braking power when full brake is applied. Large amount will shorten the braking time but it may damage your pinion and spur. Please select the most suitable brake amount as per your car condition and your preference.

8).Initial Brake Force

It's also known as "min. brake force". It's the force when pushing throttle trigger from neutral zone to the initial brake position.

9).Drag Brake

Drag brake is the braking power produced when releasing the throttle trigger from full speed to neutral zone. (Attention! Drag brake will consume much power, so apply it cautiously.)

10).Drag Brake Rate

It's the rate at which the drag brake increases from zero to the pre-set value when the throttle trigger enters the neutral range. A suitable rate can make the vehicle stop stably. You can choose the drag brake rate from level 1 (very soft) to level 9 (very aggressive) as per the track, tires' grip, and etc.

11).Neutral Range

As not all transmitters have the same stability at "neutral position", please adjust this parameter as per your preference. You can adjust to a bigger value when this happens.

12).Start Mode / Punch

You can choose the punch from level 1 (very soft) to level 9 (very aggressive) as per the track, tires, grip, your preference and etc. This feature is very useful for preventing tires from slipping during the starting-up process. In addition, "level 7/8/9" have strict requirement on battery's discharge capability. It may affect the starting-up if the battery discharges poorly and cannot provide large current in a short time. The car stutters or suddenly loses power in the starting-up process indicating the battery's discharge capability is not good, and then you need to reduce the punch or increase the FDR (Final Drive Ratio).

13).PWM Drive Frequency

The acceleration will be more aggressive at the initial stage when the drive frequency is low; a higher drive frequency is smoother but this will create more heat to the ESC.

14).BEC Voltage

This item is not programmable and fixed at 7.4V.

15).Freewheeling/DEO

For regular vehicles, we recommend disabling this function. With it disabled, your vehicle can have quick acceleration. For a crawler (simulation model), we suggest enabling it. With it enabled, you crawler can have better linearity during a low-speed running and also less heat.

6-2. ESC Programming

Program your ESC with a LED program card

The LED program card is an optional accessory for updating the firmware of car ESCs. Its friendly interface makes the ESC programming easy and quick. Before the programming, you need to connect your ESC to the program card via a White/Red/Black PVC cable with two JR male connectors (one end of the cable to the separate programming port on the ESC and the other end to the port marked with " " on the program card), and then turn on the ESC, all programmable items will show up a few seconds later. You can select the item by choosing via "ITEM" & "VALUE" buttons on the program card. Press the "OK" button to save all new settings to your ESC.

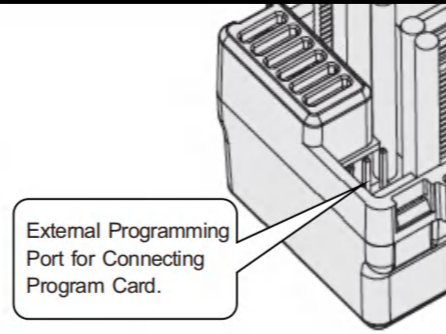

6-3. Factory Reset

Restore the default values with a LED program card

After connecting the LED program card to the ESC, press the "RESET" button and the "OK" button to factory reset your ESC.

6-4. Troubleshooting

Trouble	Possible Cause(s)	Solution(s)
The ESC was unable to start the status LED and the motor after it was powered on.	<ol style="list-style-type: none"> 1. No power was supplied to the ESC. 2. The ESC switch was damaged. 	<ol style="list-style-type: none"> 1. Check if all ESC & battery joints or connections have been well soldered or firmly connected, re-solder them if necessary. 2. Replace the broken switch.
The ESC was unable to start the motor (but the Red status LED flashed) after it was powered on.	The throttle control cable was reversely plugged in or in the wrong channel on the receiver, or the throttle stick/trigger was not moved to the neutral position.	Plug the throttle control cable in the TH channel on receiver, or fine-tune the neutral position, if the transmitter supports the "forward/reverse or backward" proportion setting, then you need to set the proportion to 5:5.
The vehicle ran backward when you pulled the throttle trigger towards you.	<ol style="list-style-type: none"> 1. The ESC-to-motor wiring order was incorrect. 2. Incorrectly set the direction of the throttle channel. 	<ol style="list-style-type: none"> 1. Swap the two motor wires. 2. Change the direction of the throttle channel from "NOR" to "REV" or "REV" to "NOR".
The motor suddenly stopped or significantly reduced its output in operation.	<ol style="list-style-type: none"> 1. The receiver was influenced by some foreign interference. 2. The LVC protection was activated. 3. The ESC thermal protection was activated. 	<ol style="list-style-type: none"> 1. Check all devices to find out all possible causes, and check the transmitter's battery voltage. 2. The Red LED keeps flashing indicating the LVC protection is activated, so please replace your battery pack. 3. The Red LED keeps flashing indicating the ESC thermal protection is activated, please let your ESC cool down before using it again.
The vehicle could run forward but could not reverse.	<ol style="list-style-type: none"> 1. The throttle neutral position on your transmitter was actually in the braking zone. 2. Set the "running mode" improperly. 3. The ESC was damaged. 	<ol style="list-style-type: none"> 1. Re-calibrate the throttle neutral position, no LED on the ESC will turn on when the throttle trigger/stick is at the neutral position. 2. Set the "running mode" to "Fwd/Rev/Br" or "Fwd/Rev". 3. Contact your dealer for repair service.
The vehicle moved forward or backward slowly when the throttle trigger was at the neutral position.	<ol style="list-style-type: none"> 1. The signals emitted by the transmitter were not stable. 2. The throttle range was not calibrated properly. 	<ol style="list-style-type: none"> 1. Replace the transmitter with another one that has stable signals. 2. Please fine-tune the neutral position on the transmitter.
The LED display kept displaying "----" after the LED program card was connected to the ESC.	Connected the LED program card to the wrong port on the ESC.	Connect the LED program card to the separate port marked with " ⊖ ⊕ ⊔ " on the ESC.

7. RESCUER Specifications

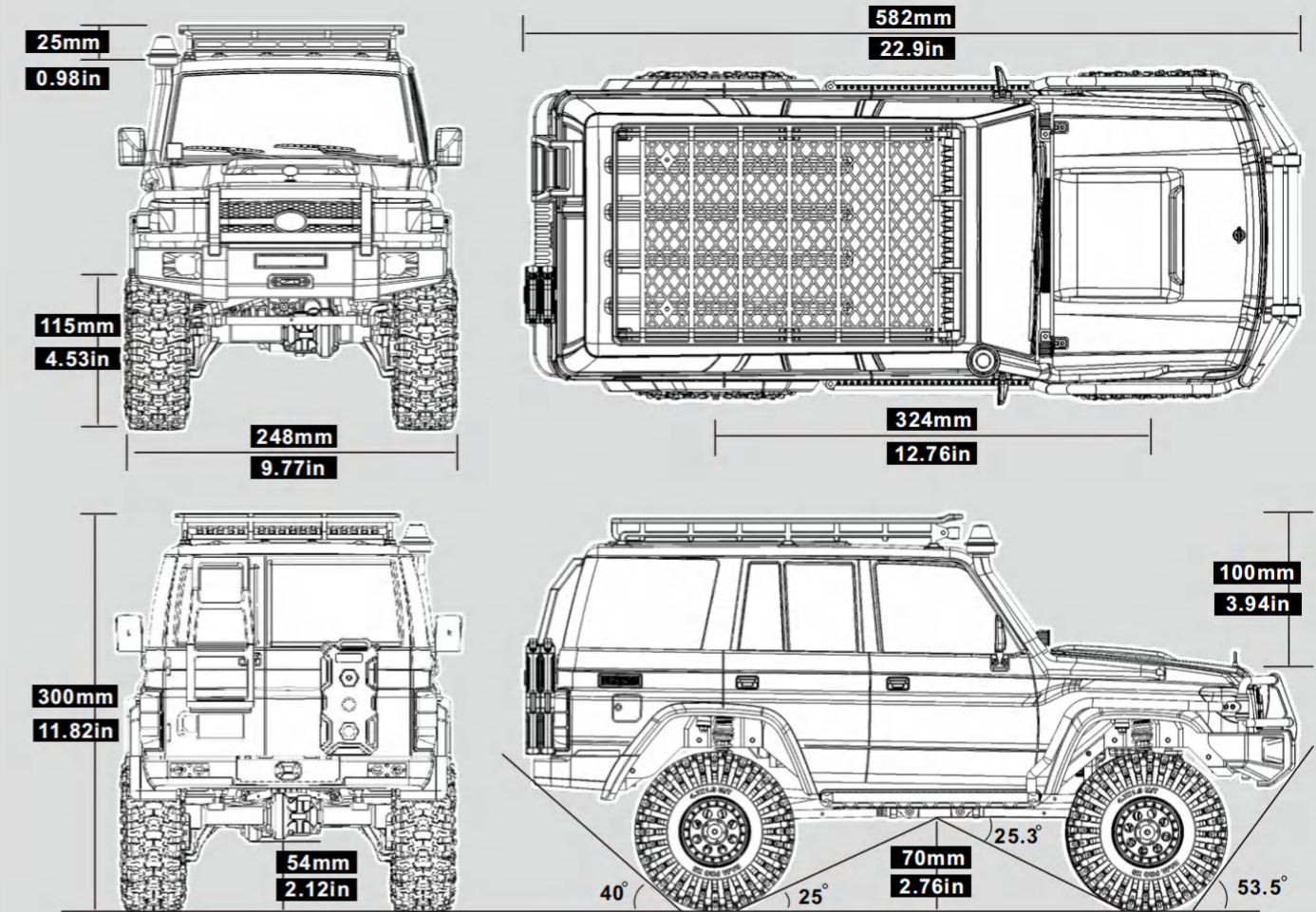

Item No	EX86190	Wheel	115*42mm	Motor	550/8020
Item Name	RESCUER	Clearance	70mm(classis) 54mm (steel)	Steering Servo	Digit Metal Gear-30KG
Scale	1/10	Weight	3.56kg(No battery)	Geard Ratio	26.6:1(H),50.4:1(L)
Description	RTR-Crawler	Radio/Rx	2.4G/8CH	Breakover	25.3°
Drive Type	4WD	R/C Distance	<120m>100m	Approach	53.5°
Length	582mm	Battery	2S or 3S Lipo Recommendations	Departue	40°
Width	248mm	Battery Size	<142*48*55mm(L*W*H)	Body Color	PC Black/Silver Grey /Royal Blue
Height	300mm	Number Of Differentials	"Steel" 2P	Gift Box Size	630*285*325mm
Wheel Base	324mm	ESC	WP-880 / 80A	Piece per Carton	1P

8. All the ways done, your car is ready to run. Hope you enjoy the fun in driving it.

Tip: Always turn off the receiver and then the transmitter when not in use. Clean the car before storage.

Vehicle Maintenance:

- 1). Please remove the batteries from both the vehicle and the transmitter, when the car is out of use for a long time,
- 2). Before each use, please carefully check whether the circuit wires of the model are tight and free of loose connectors. Also, please carefully inspect if the wheels are securely fastened—loose wheels can cause excessive wear to parts such as the drive shaft, wheel cups, or wheel hubs.
- 3). Ensure the unused battery pack should be charged to 50-60% capacity before being stored in a dry and cool place, out of the reach of children.
- 4). After each use, please carefully check if all parts are intact, and repair or replace the worn parts. Use a fine brush to sweep the sand, marl and other dirt inside the model, then wipe it cleanly by a soft cloth.

9. Vehicle parts

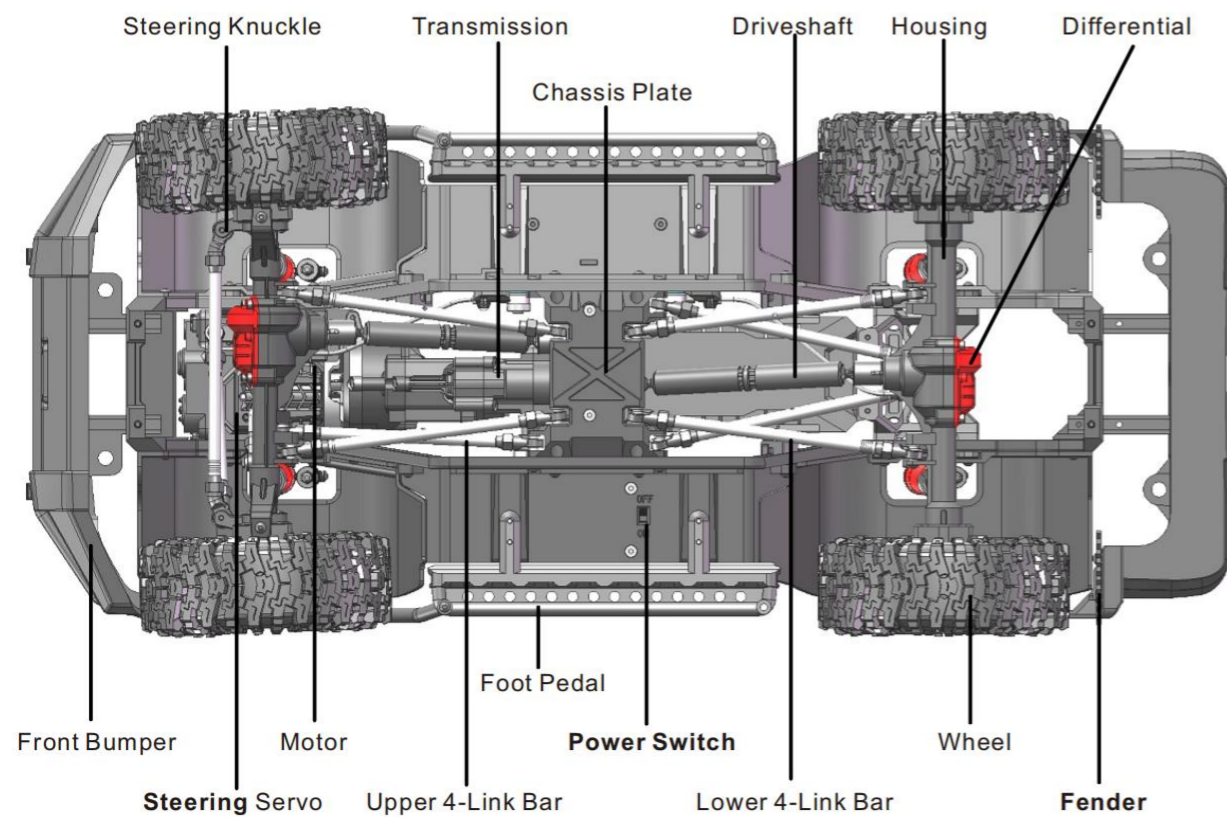
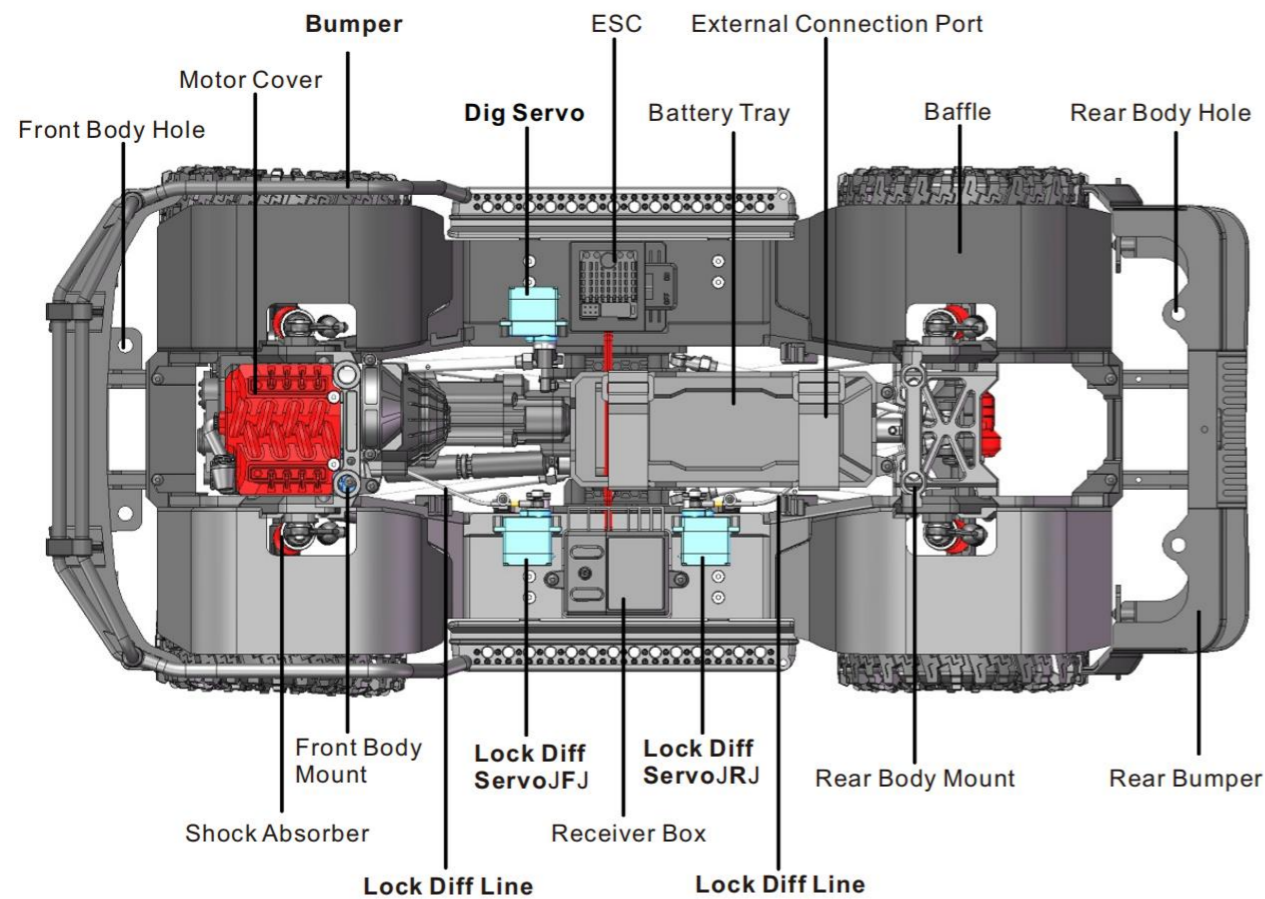

10. Troubleshooting

Problem	Possible Cause	Solution
Car does not respond during operation	Electronic plugs loose or fall off	Switch off and reconnect
	Vehicle battery not charged, activating the ESC low voltage cut-off to protect the battery	Replace/recharge the vehicle battery
	Motor or ESC dirty or damaged	replace new Motor (recommend to purchase factory Motor)
	ESC failed	replace new ESC (recommend to purchase factory ESC)
	ESC power off by overheated Motor	Stop operation and cool the ESC or Motor
	Motor overheated, demagnetized or damaged	replace new Motor (recommend to purchase factory Motor)
	Transmitter batteries low or beyond the remote control distance	Replace the transmitter batteries, adjust the remote control distance
	Transmitter damaged	Relace or contact seller
No Backward, forward normally	ESC "operation mode" setting error	Refer to manual "ESC", set "operation mode" into "forward and backward reverse with brake"
	ESC damaged	Relace or contact seller
	Throttle damaged or transmitter throttle not centered	Refer to manual "Transmitter", and reset
Car operate automatically, with no control	Throttle trim out of center on transmitter	Refer to manual "Transmitter", and reset
	Neutral throttle is in incorrect position	Adjust ESC in neutral point
Normal operation, speed shift failure	Error Operation	Ensure to operate in stop status, more refer to the Manual
	Gear Cable damage or loose	Replace the accessory or Readjust
	Servo wire inserts in wrong Receiver slot	Refer to the manual, Readjust
Sluggish Action	Battery damaged / not charged	Check, change or recharge
	Throttle trim out of center on transmitter	Adjust (refer to manual "transmitter")
	Motor dirty/ damaged	Clean/ replace
Light Function Failure after Battery properly installed	Drivetrain dirty / damaged	Check and clean
	Light Plug is not connected or in wrong position	Check the plug connection
	Transmitter Set Error or Light Control Panel Damage	Reset the Transmitter. Otherwise, please check the light control panel is damaged or not.
Lack of steering and throttle	Light Cable in wrong installation and connection	Readjust the installation and Connection
	ESC power off by overheat	Stop operation, cool the ESC
Vehicle moves left / right without steering input	Transmitter too near interfere electronical objects	Check and rebind transmitter and receiver, refer to manual
	Steering accessories damaged	Check and replace
	Wheel loose	Check and replace
Controls Reversed	Drivetrain dirty / damaged	Check and replace
	ST. REV or TH. REV	Change switch position, refer to manual
Clicking noise in operation	Check the wires between ESC and Motor correct or not	Switch the motor black and red wire
	Check the bodyshell damaged or fall off	Retrim or replace
	Loose or tight between motor gear and main gear	Reset gear mesh
Only steering, no forward and backward	Gear damaged or rocked	Remove gear cover and inspect. If necessary, replace gear
	ESC failed or abnormal	Reset the neutral point or replace
	Transmitter failed or abnormal	Relace or contact seller

Transmission Assembly-1

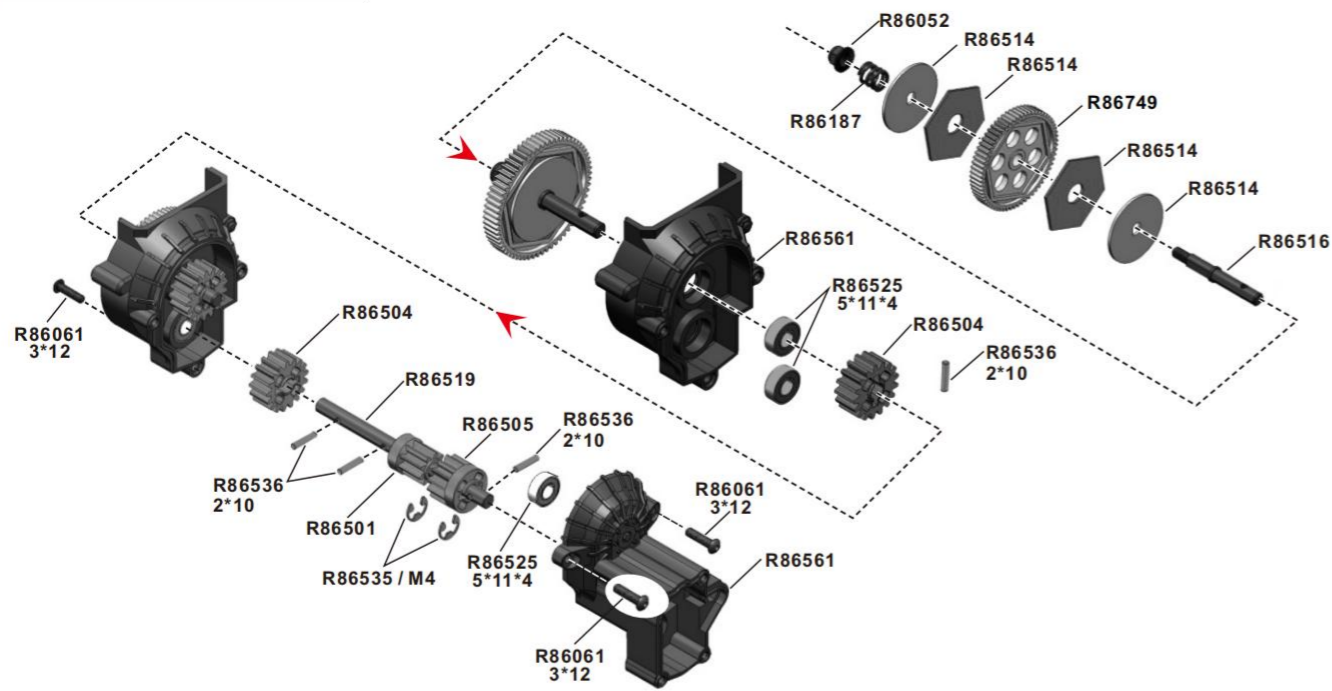

Transmission Assembly-2

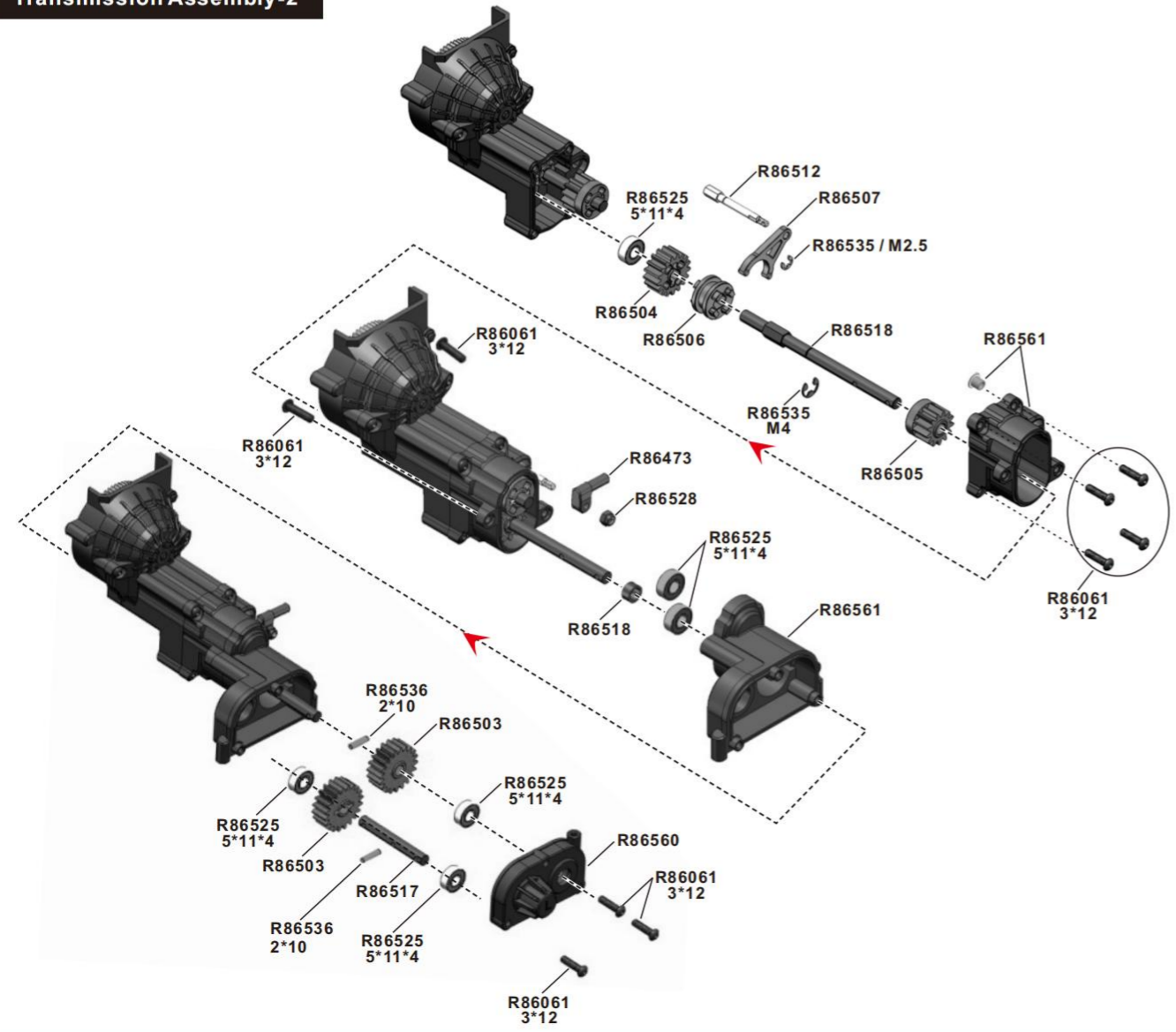

Motor/Transmission Assembly

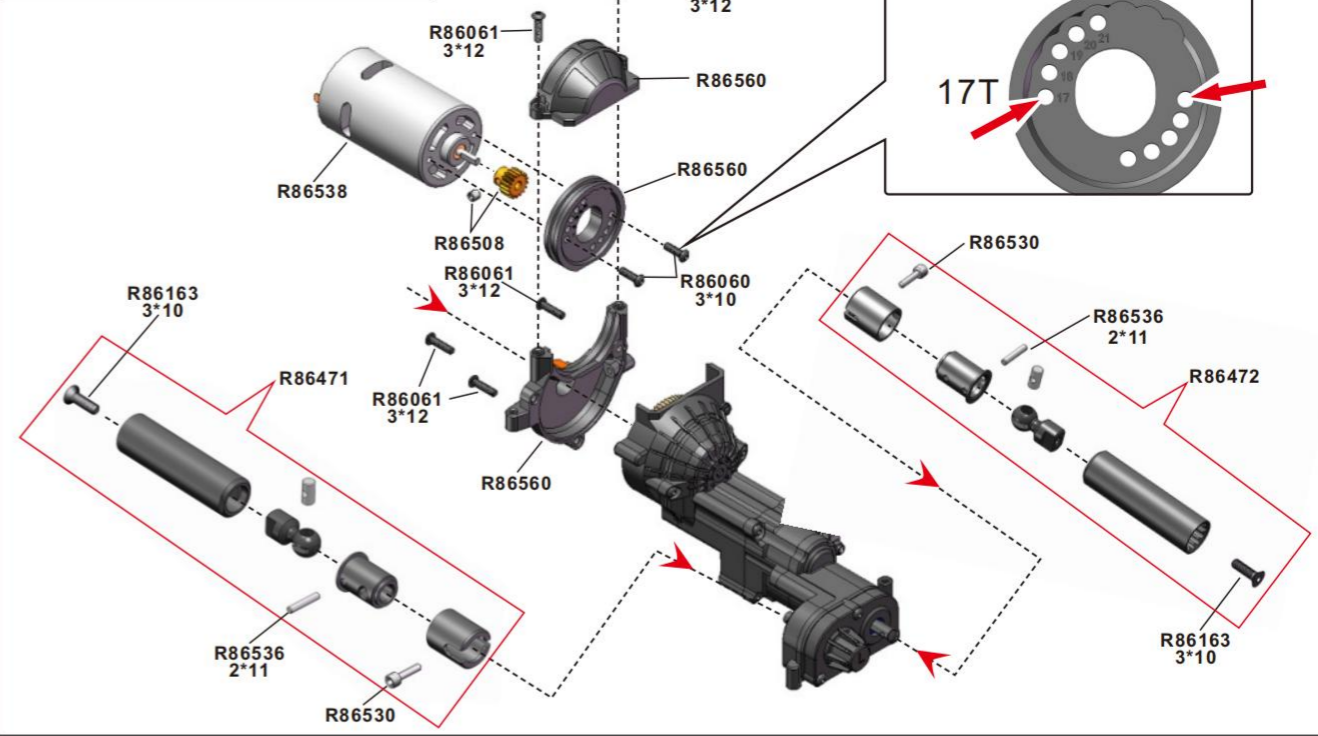

Diff.gear Assembly

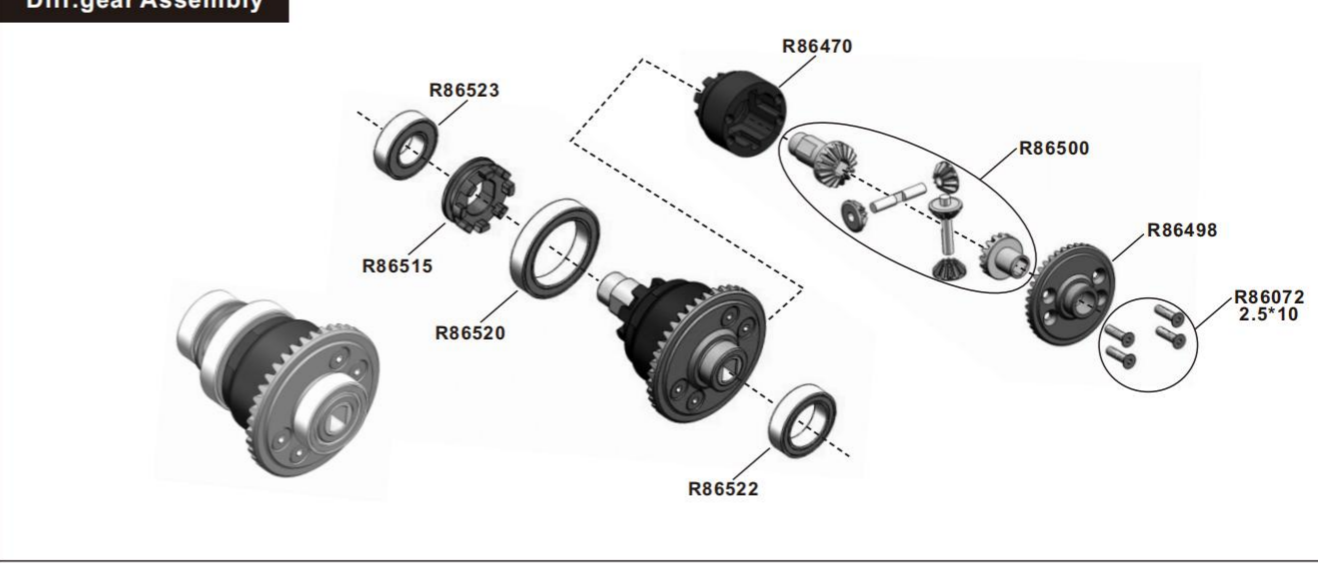

Front Axle Assembly

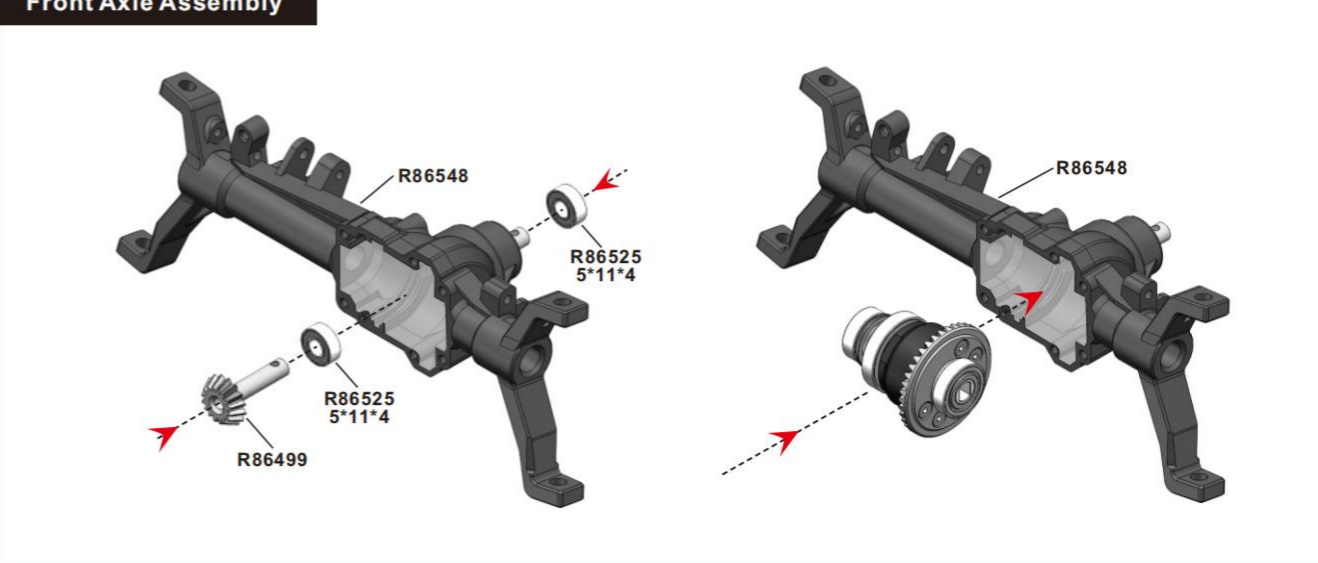

Rear Axle Assembly

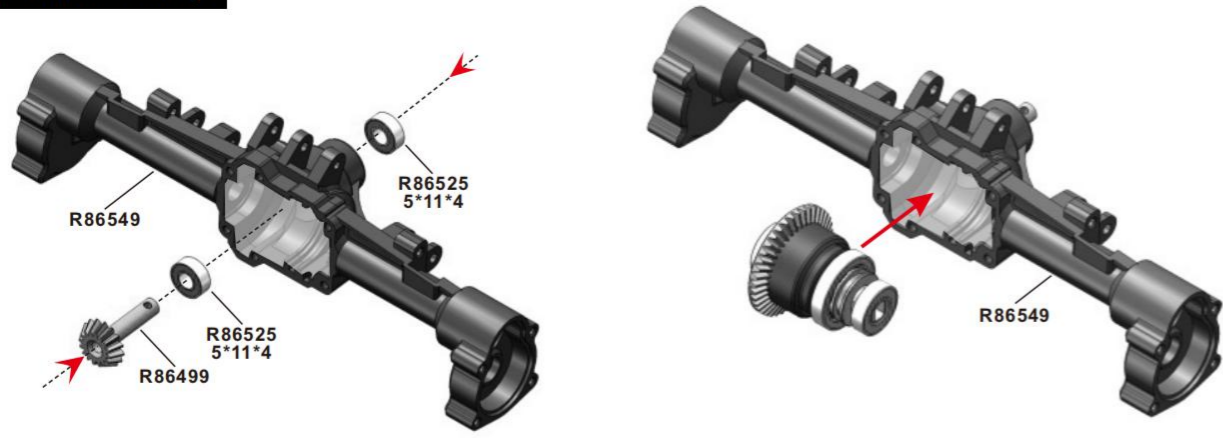

Diff. Lock Line Assembly (Front)

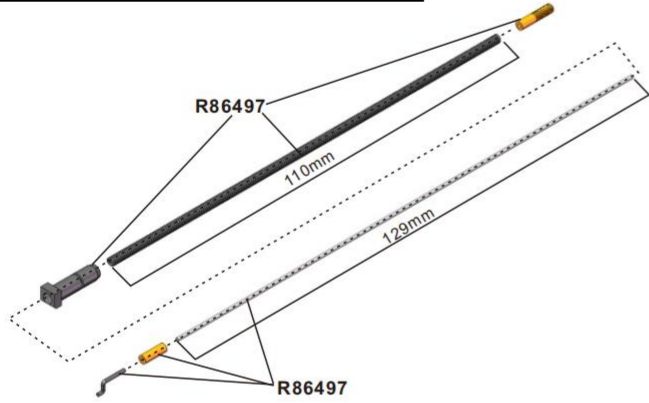

Diff. Lock Line Assembly (Rear)

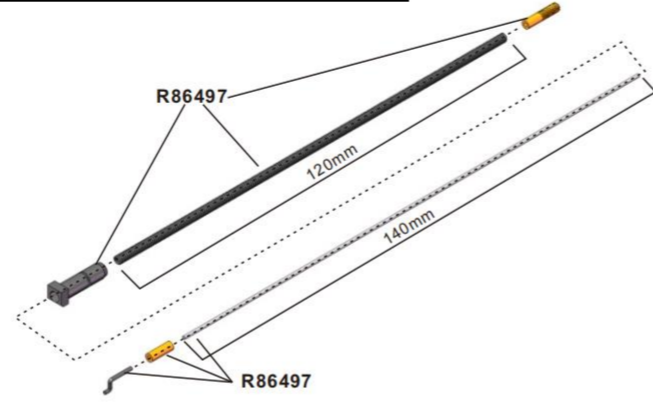

Diff. Lock Clasp (F-1)

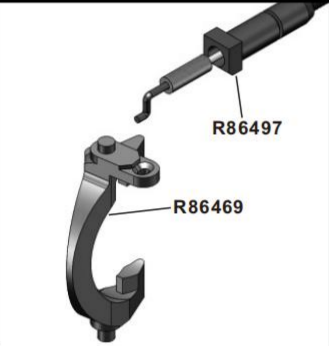

Diff. Lock Clasp (F-2)



Diff. Lock Clasp (R-1)



Diff. Lock Clasp (R-2)

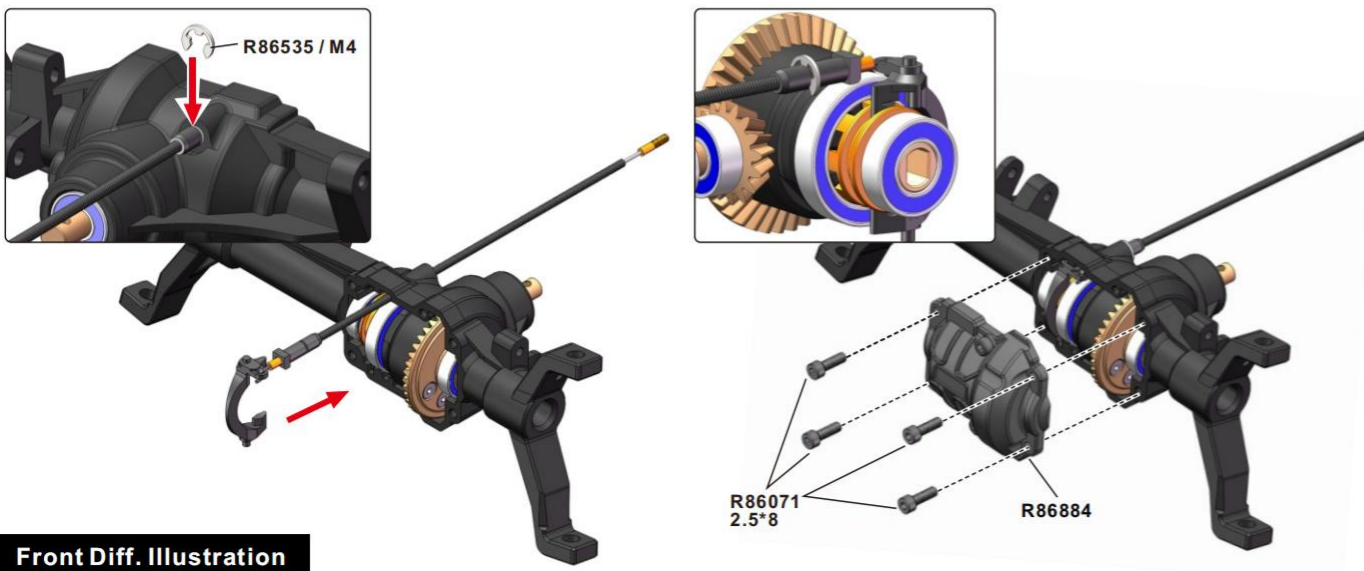

Front Diff. Illustration

Rear Diff. Illustration

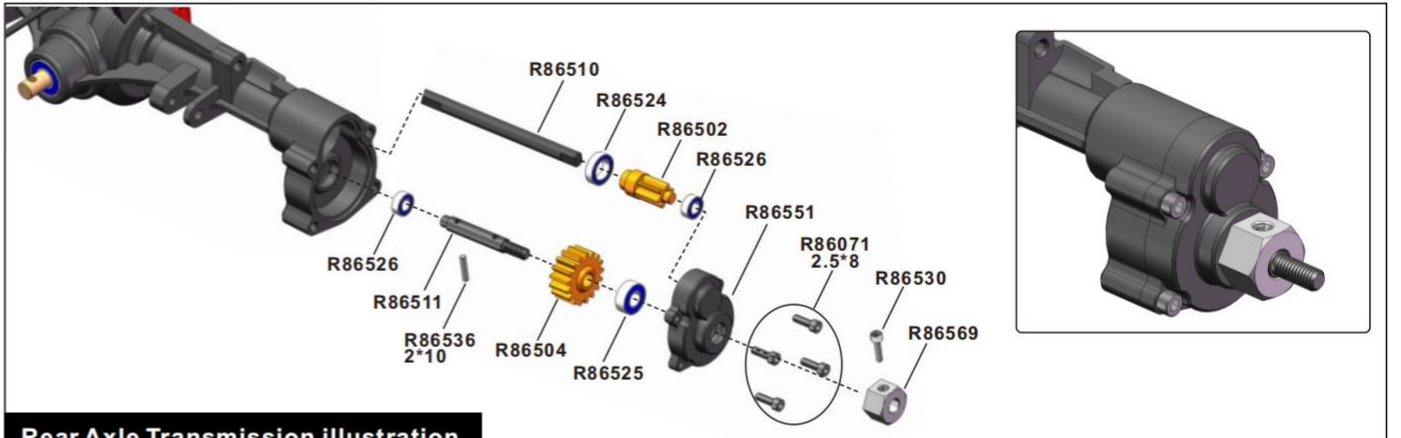
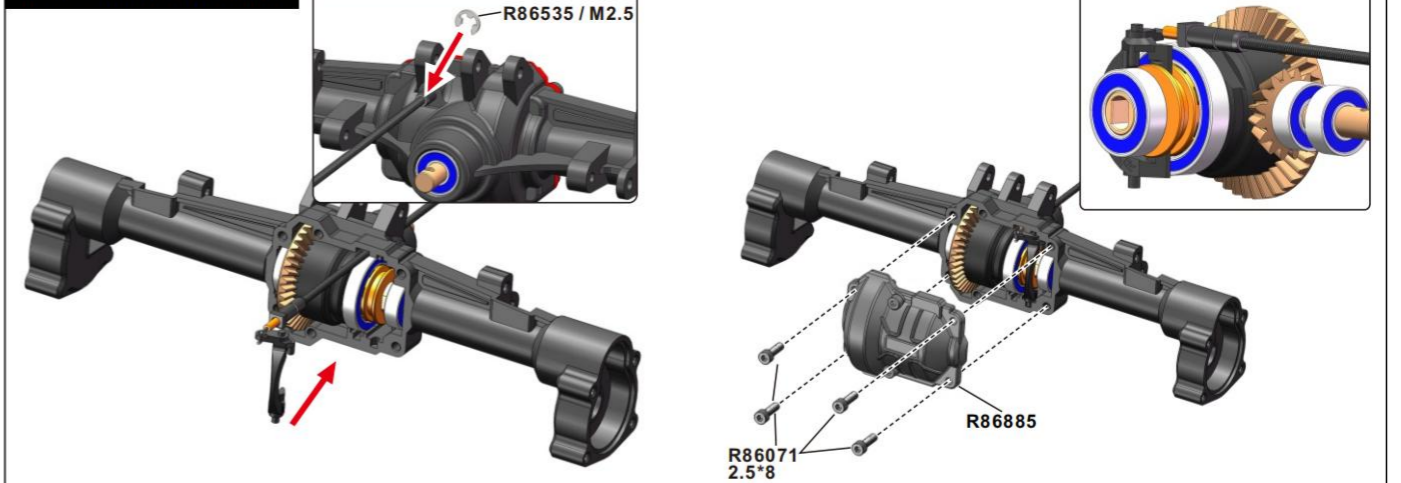

Rear Axle Transmission illustration

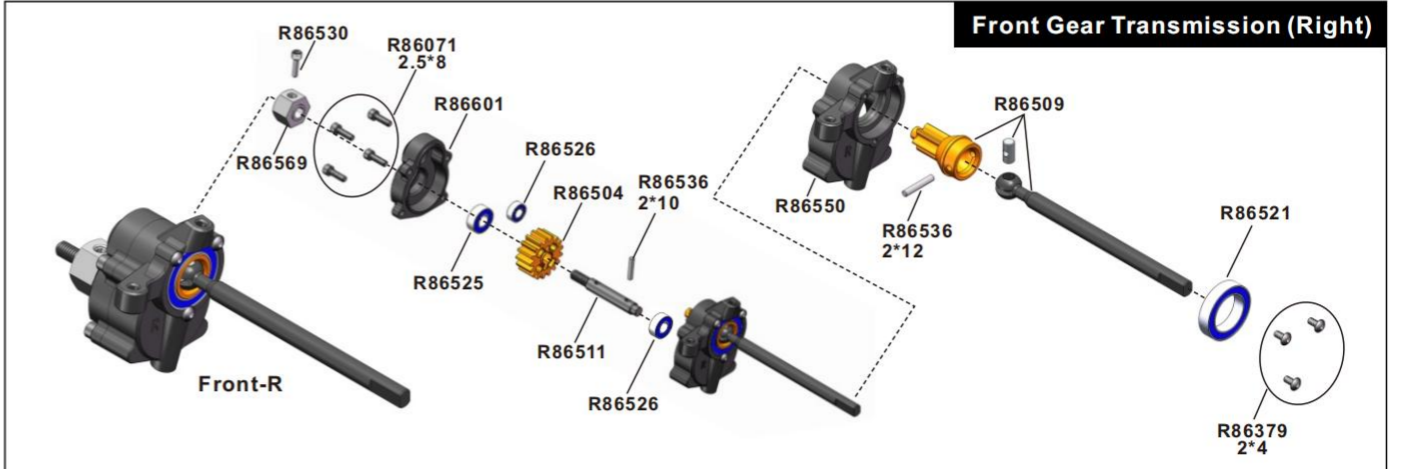

Front Gear Transmission (Right)

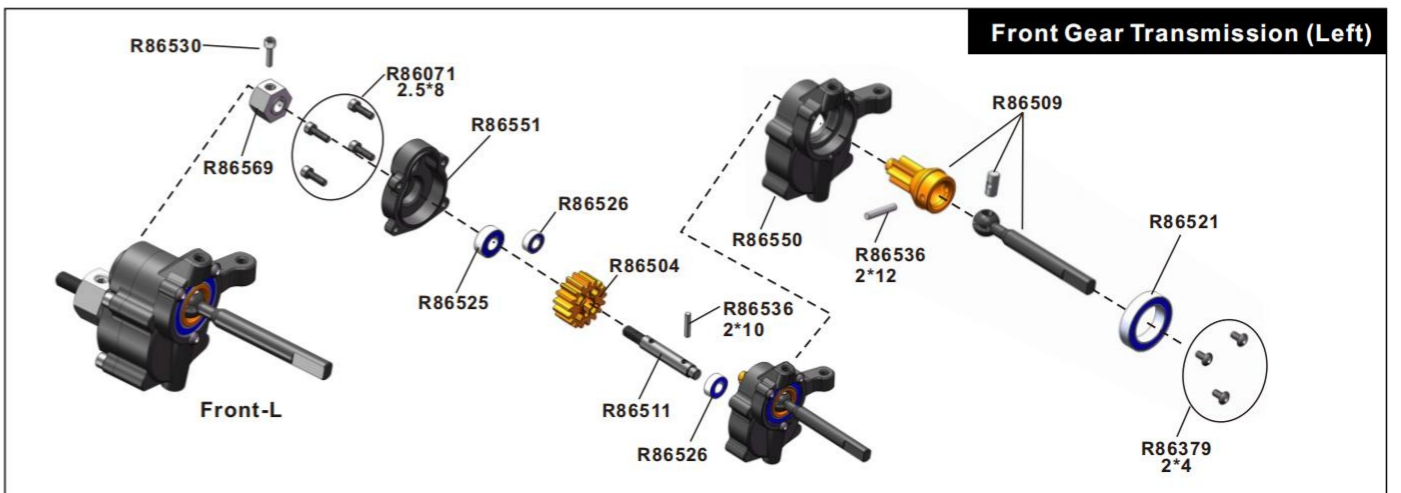

Front Gear Transmission (Left)

Shock Absorber Assembly

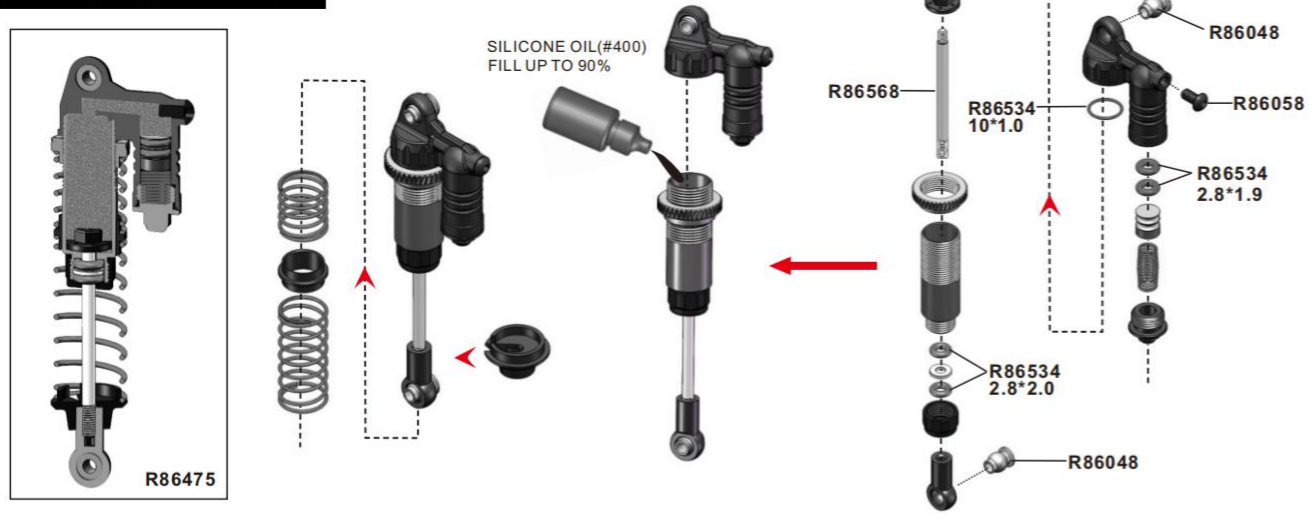

Front Axle Assembly

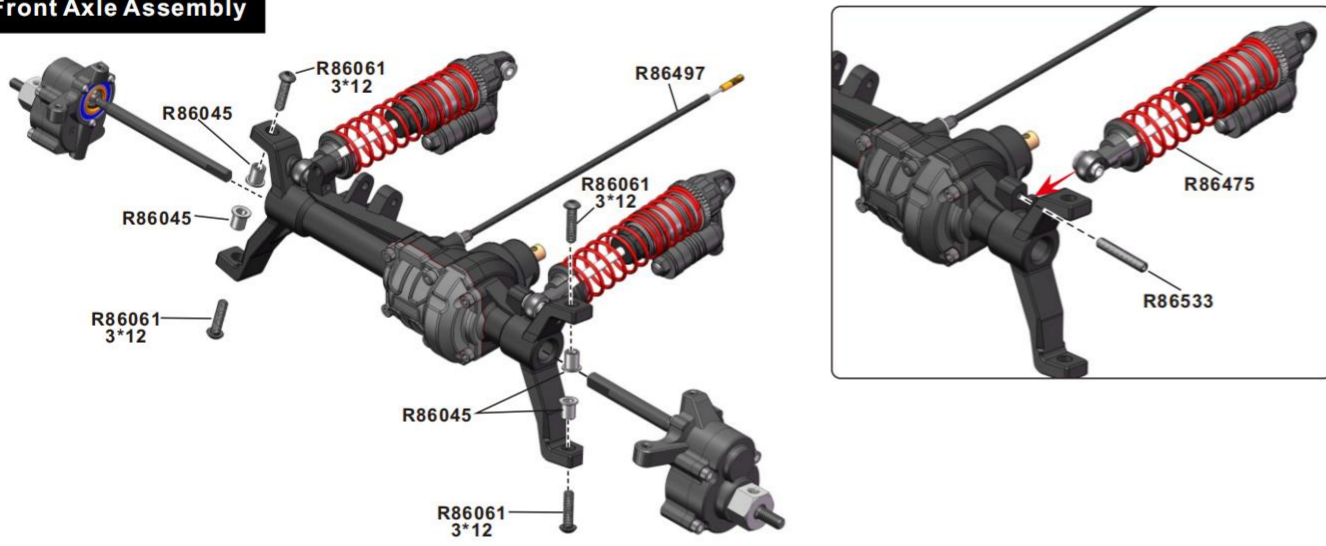

Linkage Bar Assembly

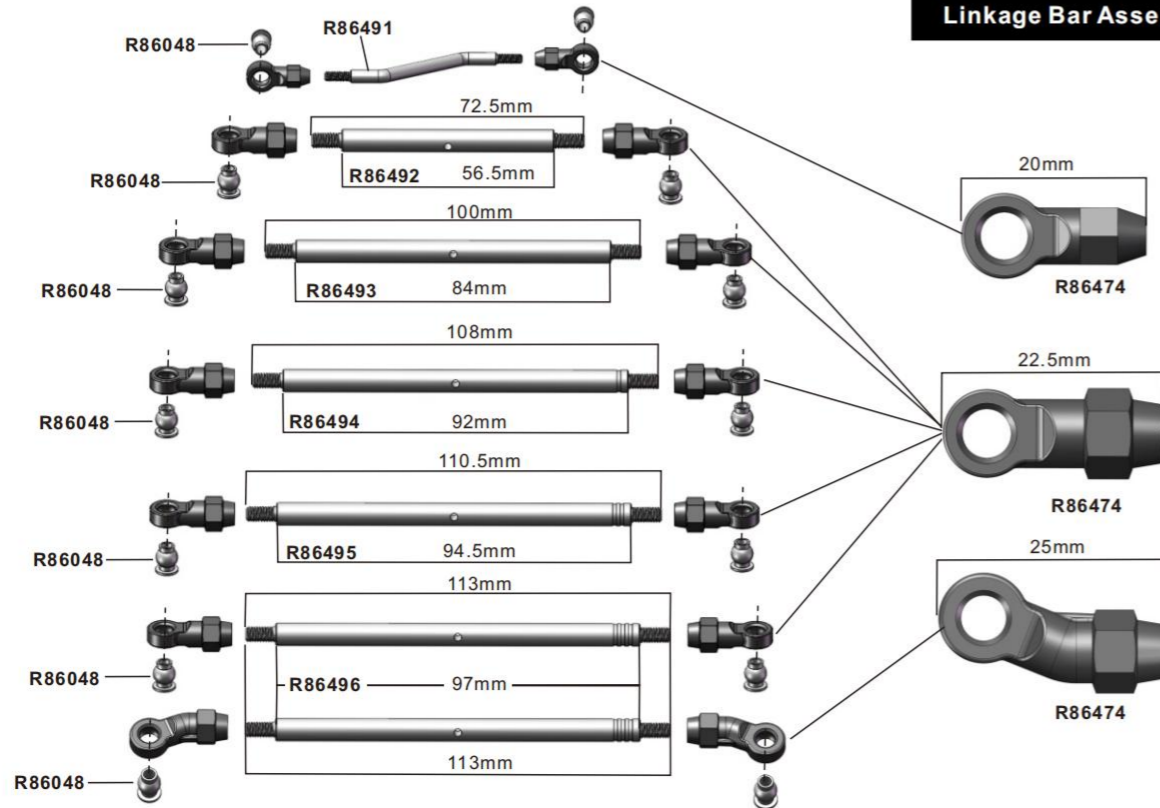

Front Steering Linkage Installation

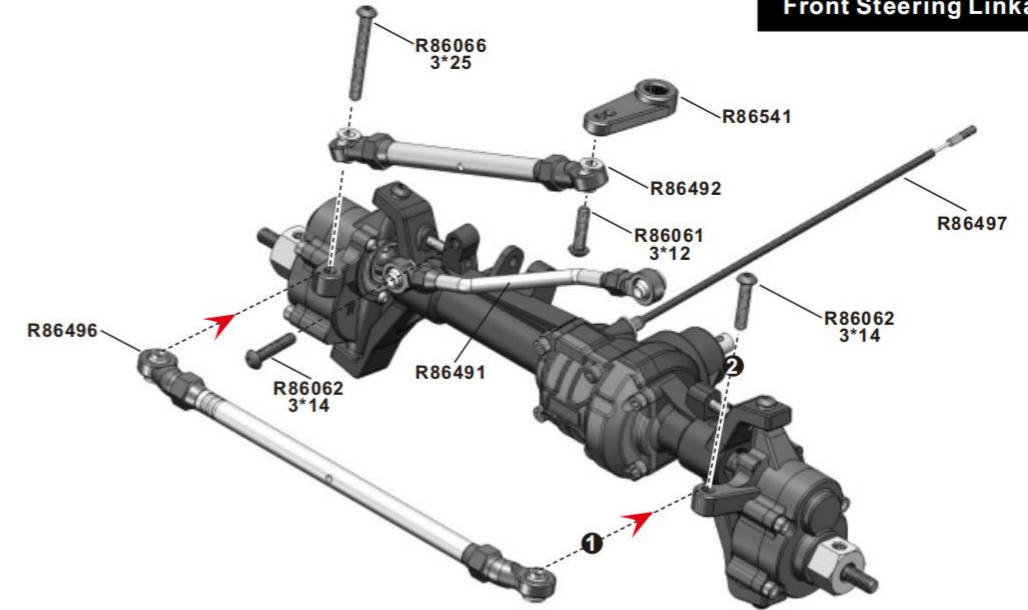

Front Suspension Linkage Installation

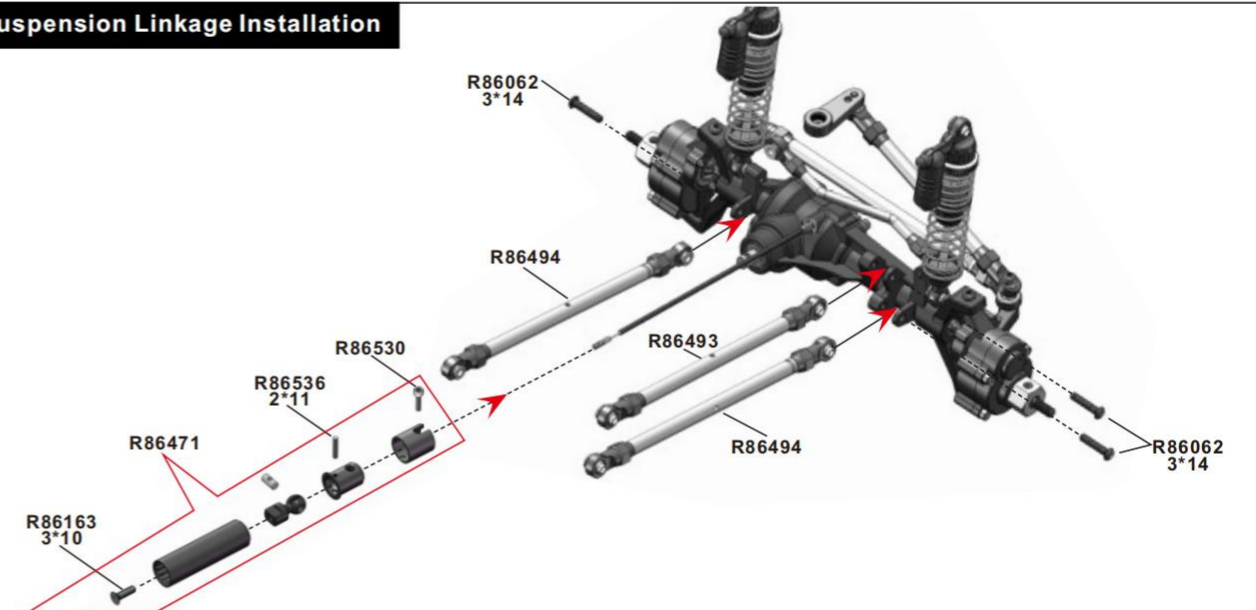

Rear Suspension Linkage Installation

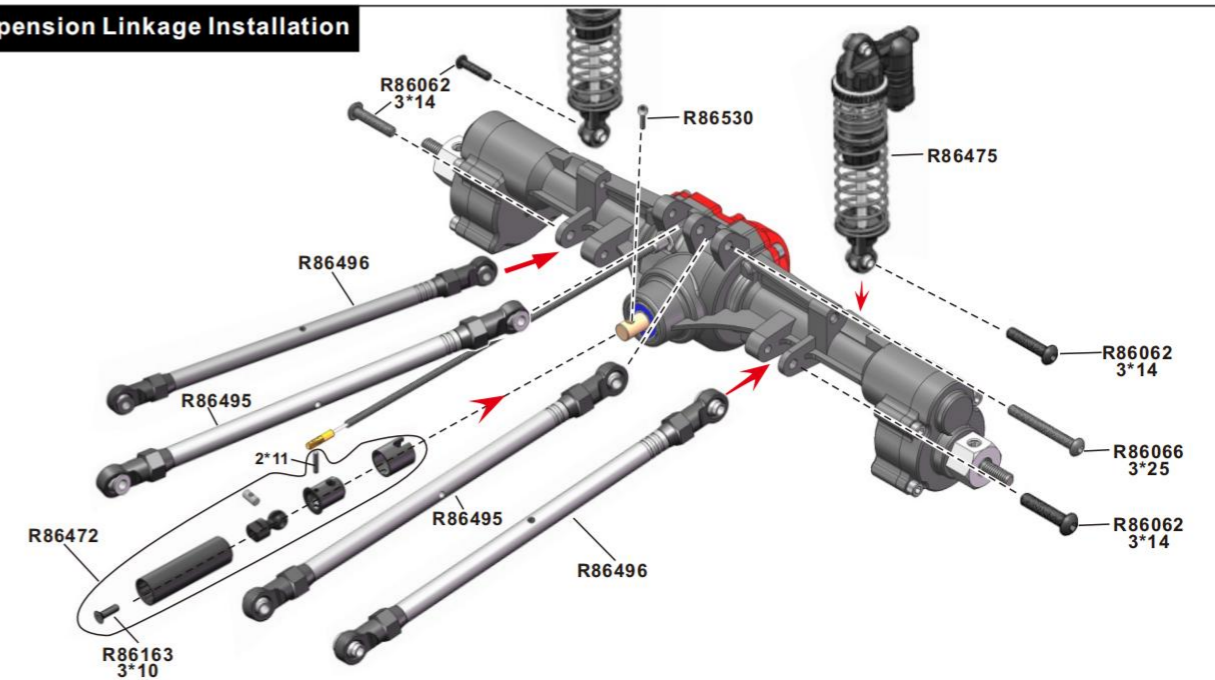

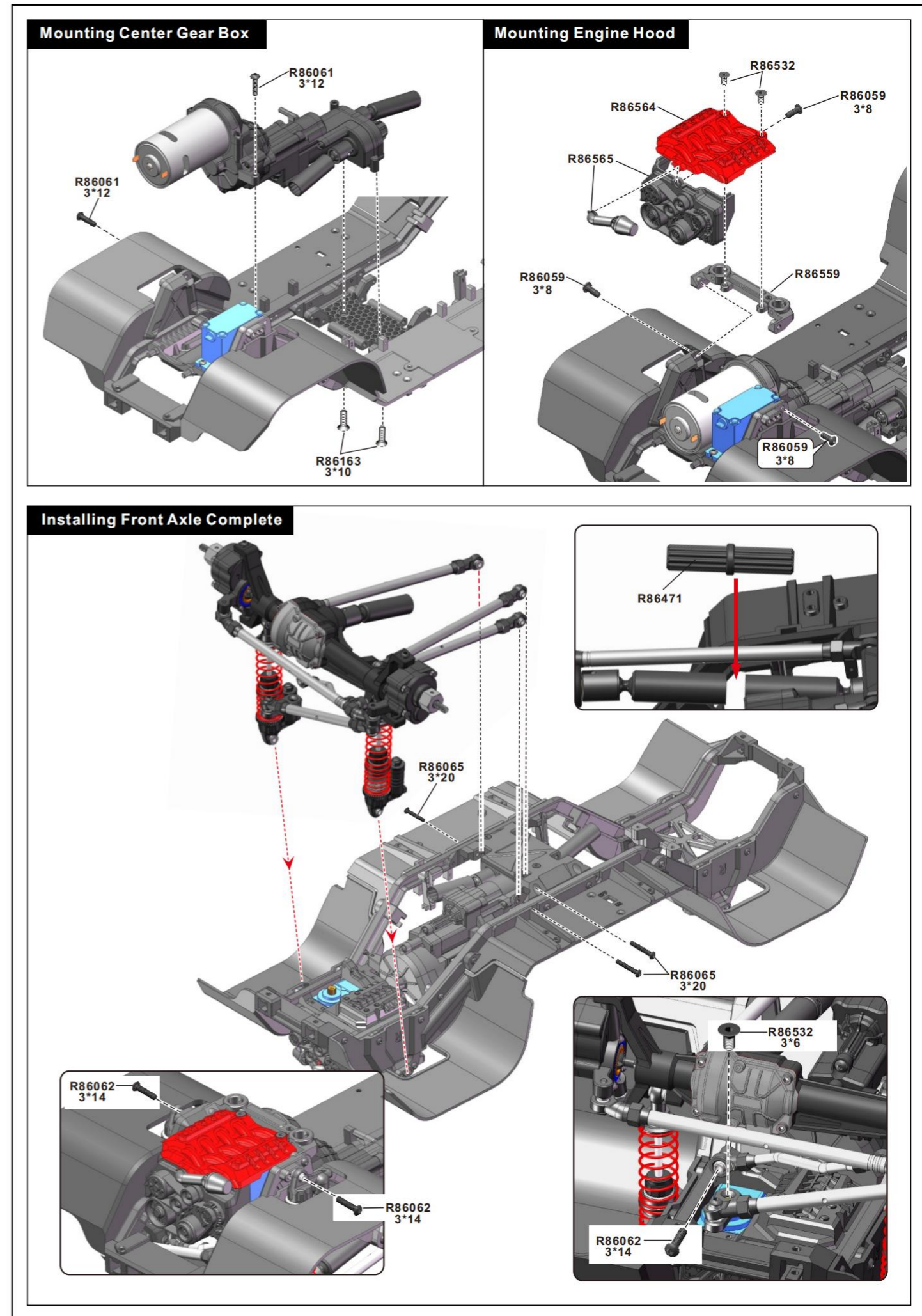
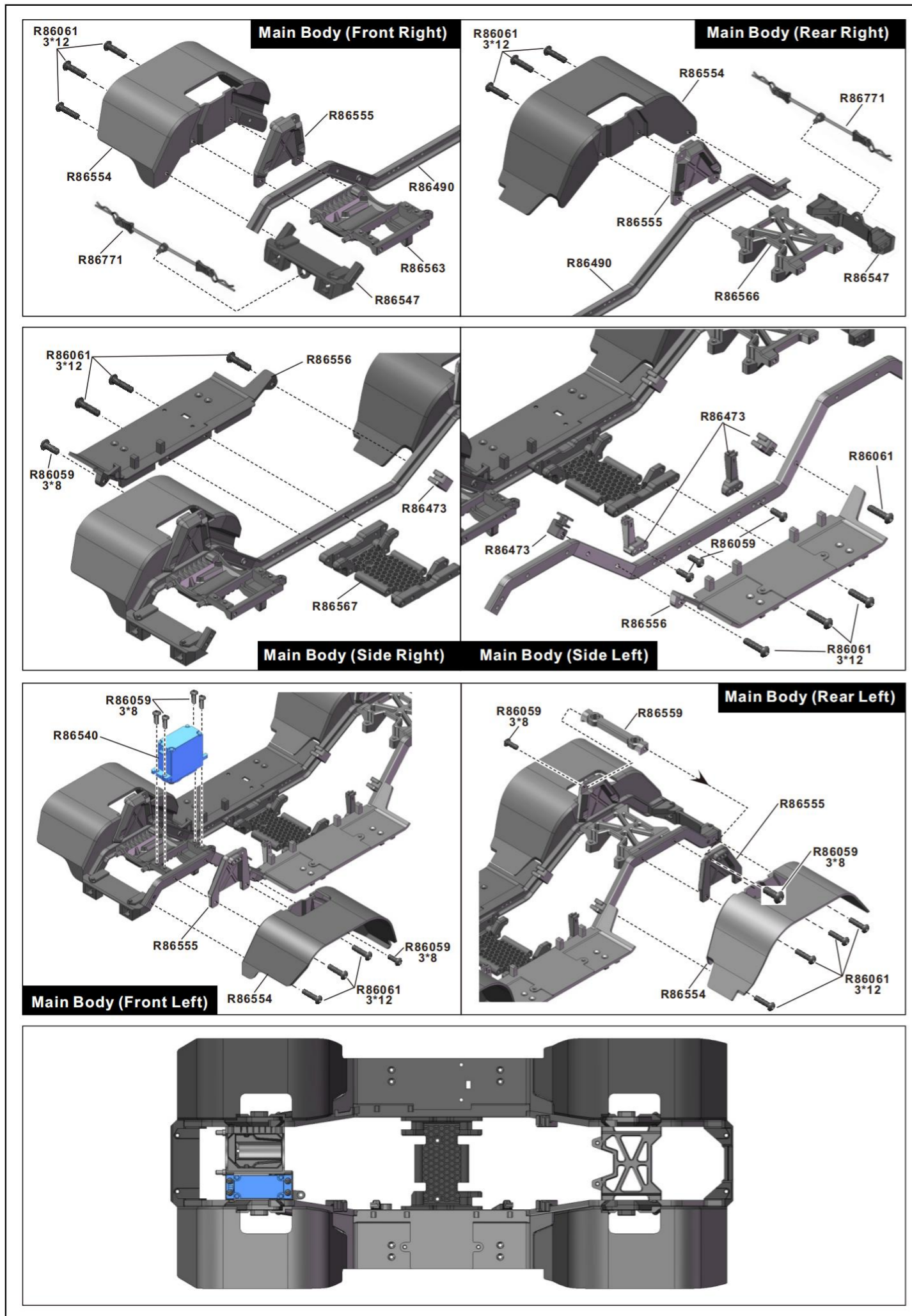

Installing Reer Axle Complete

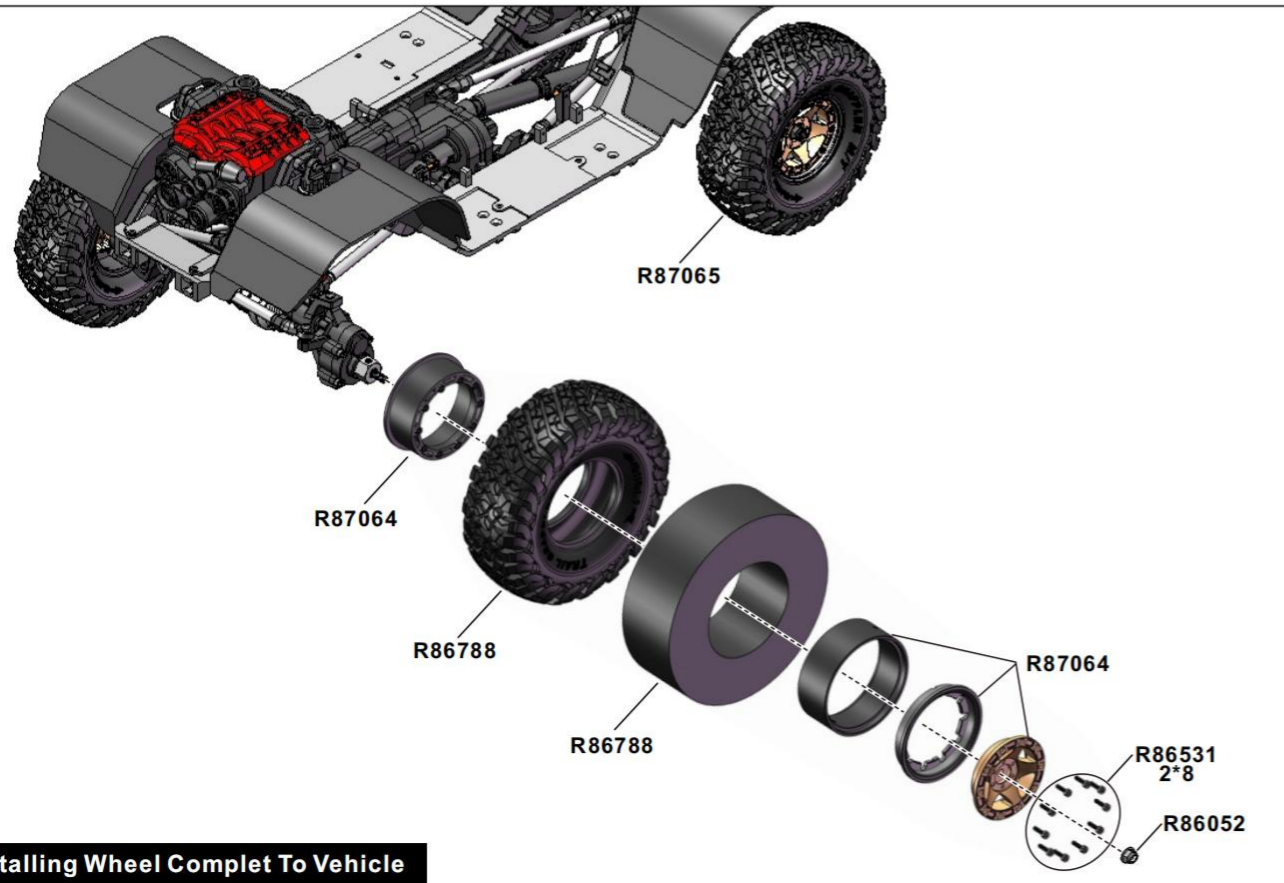
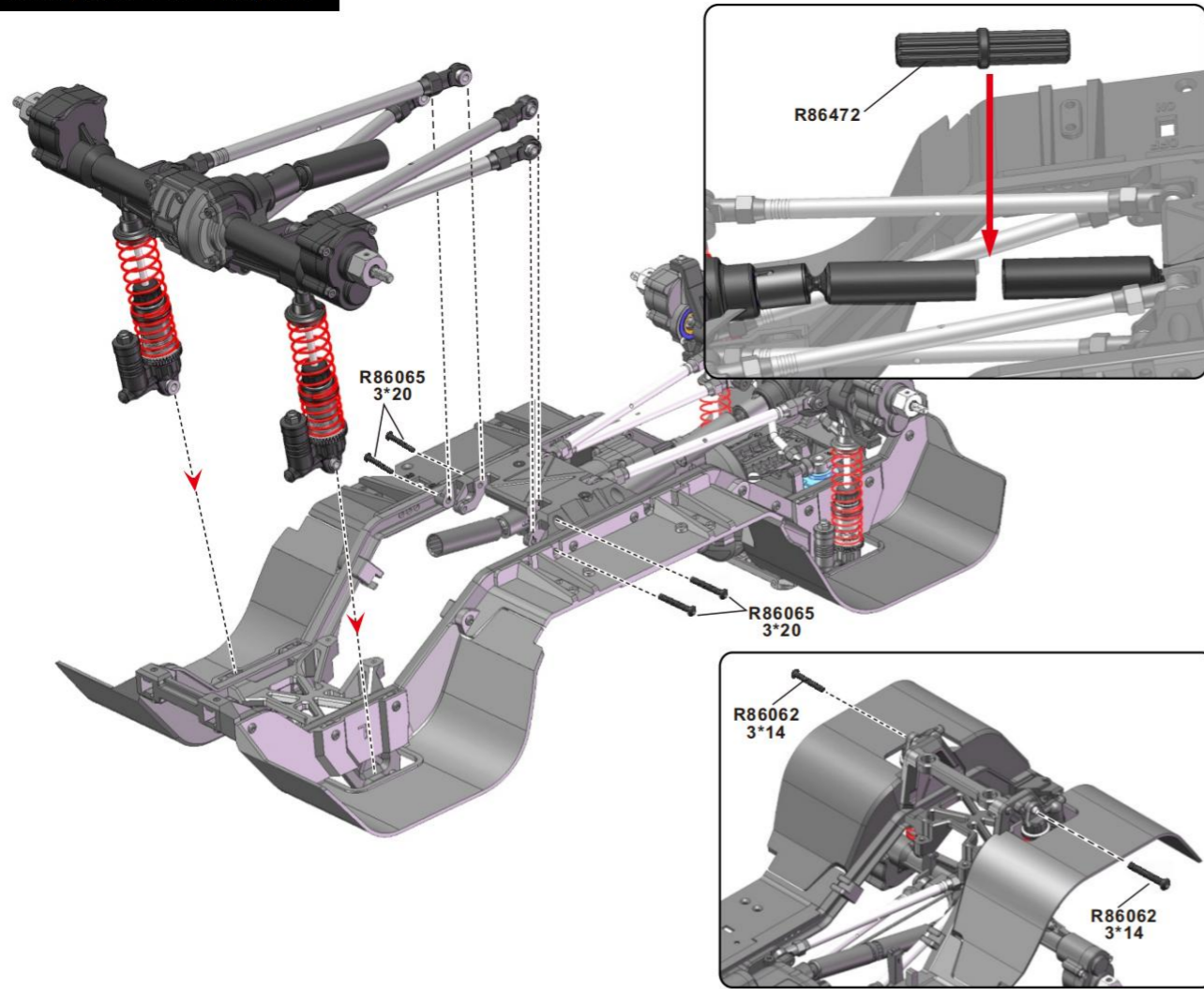

Installing Wheel Complet To Vehicle

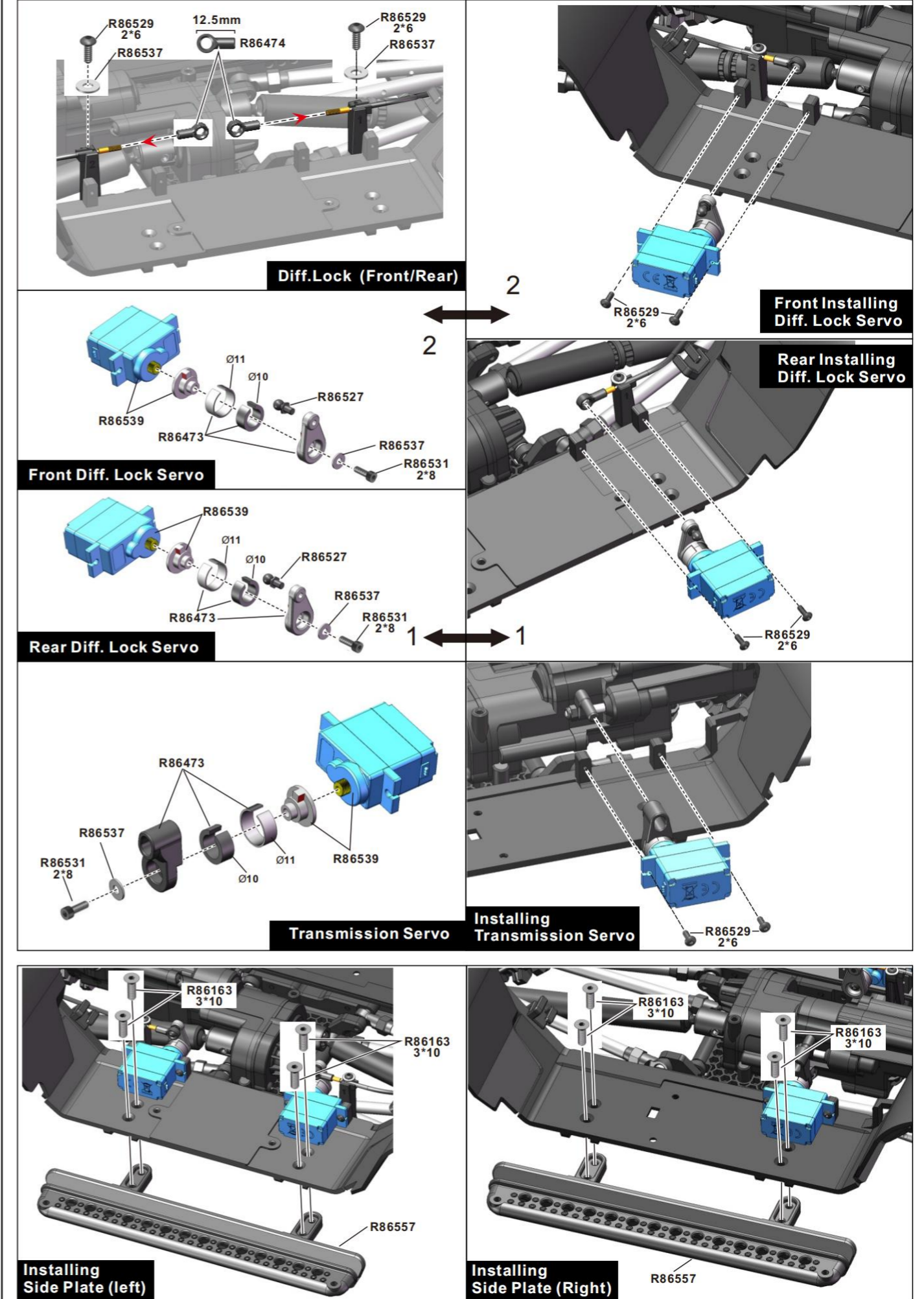

Mudguard Assembly

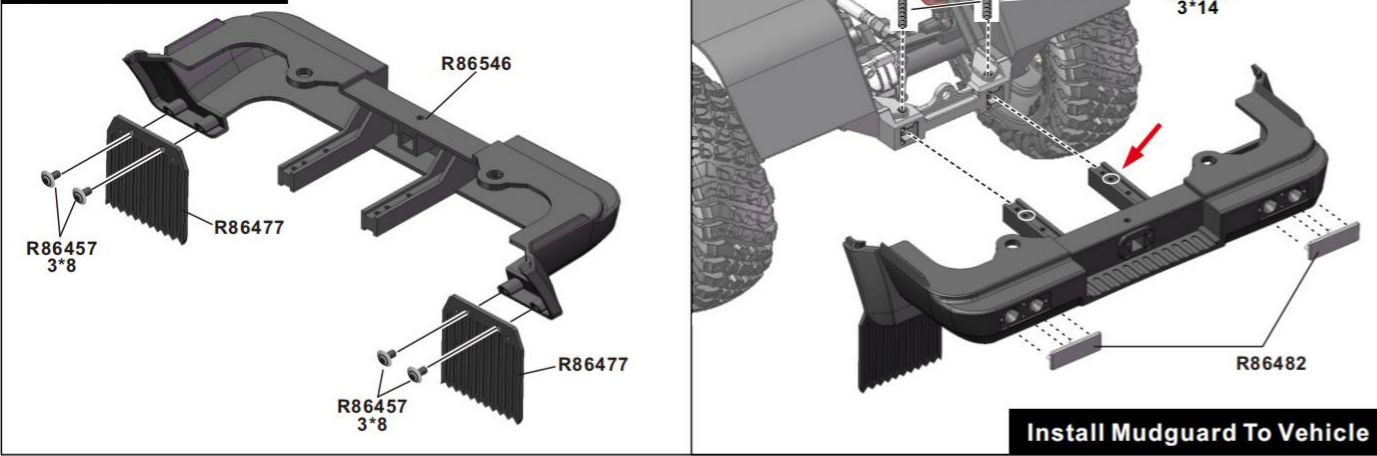

Install Mudguard To Vehicle

Front Bumper Assembly

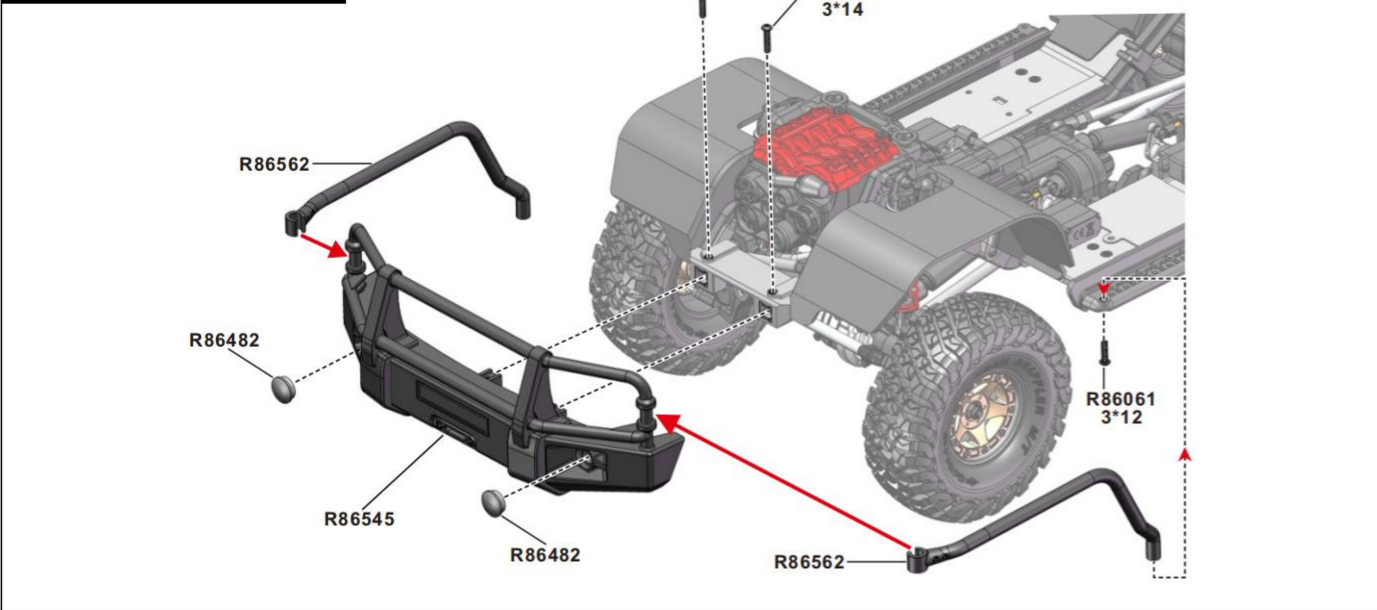

Installing Battery Holder Installing ESC

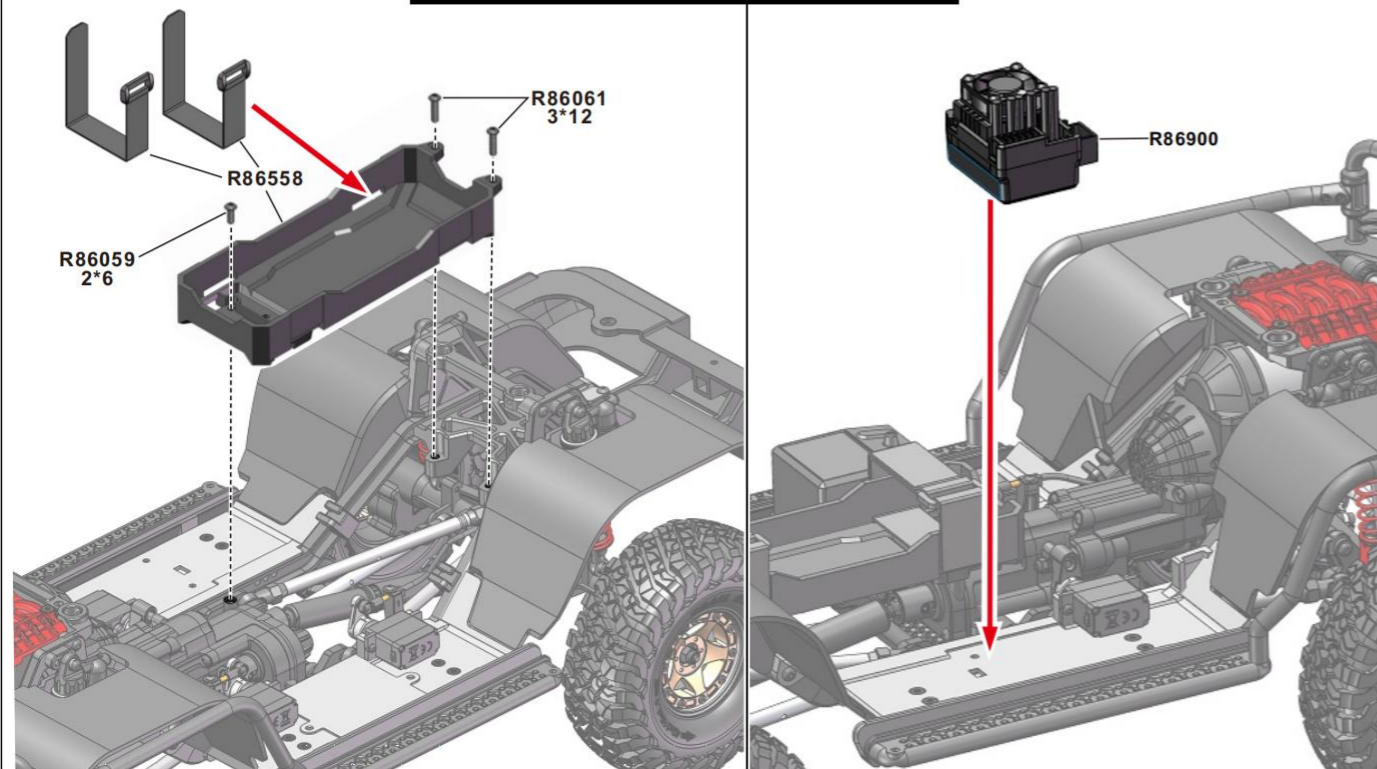

Installing Receiver

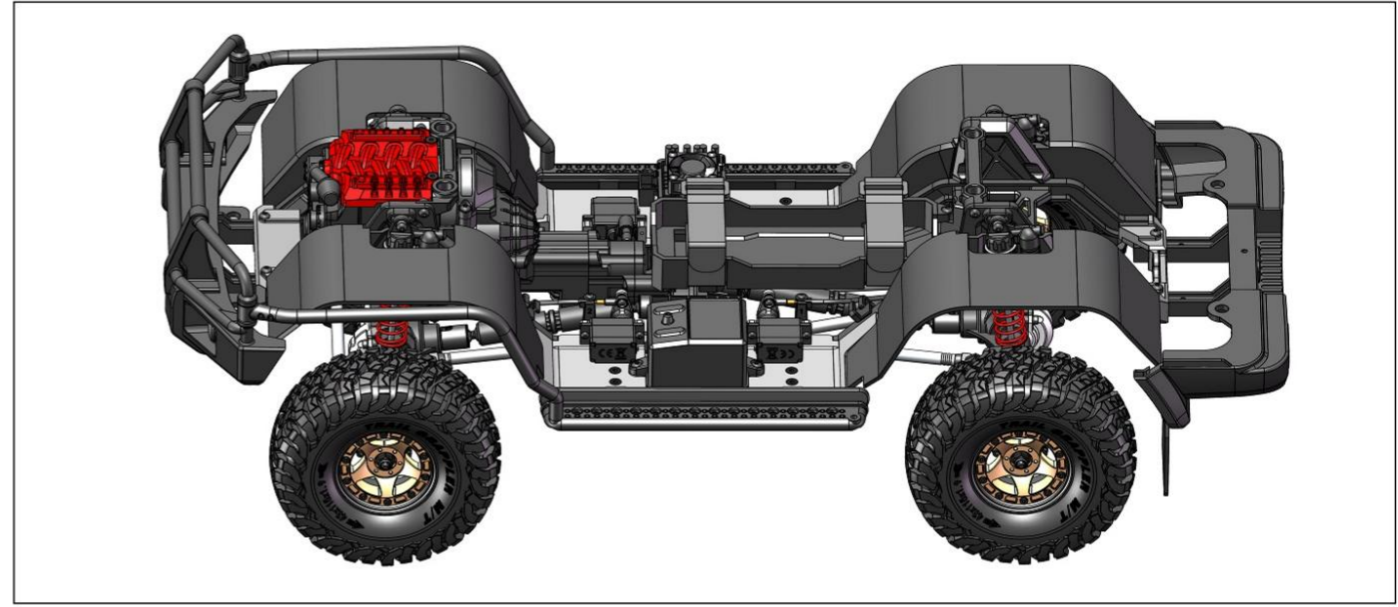
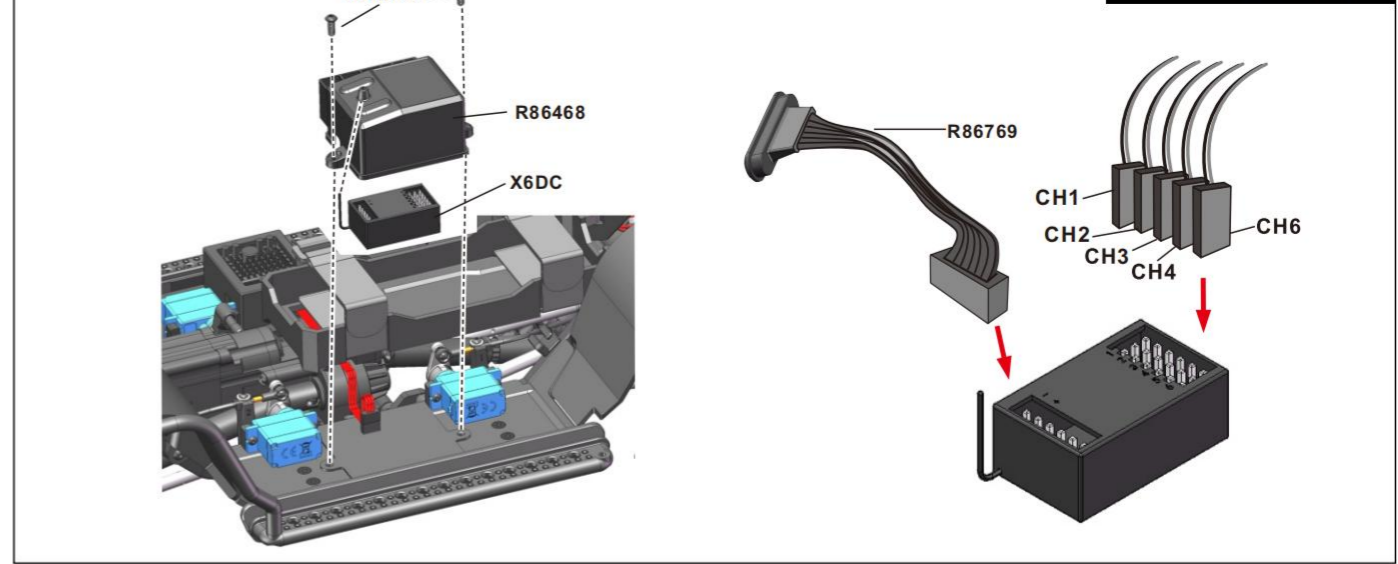

Headlight/Taillight Installation

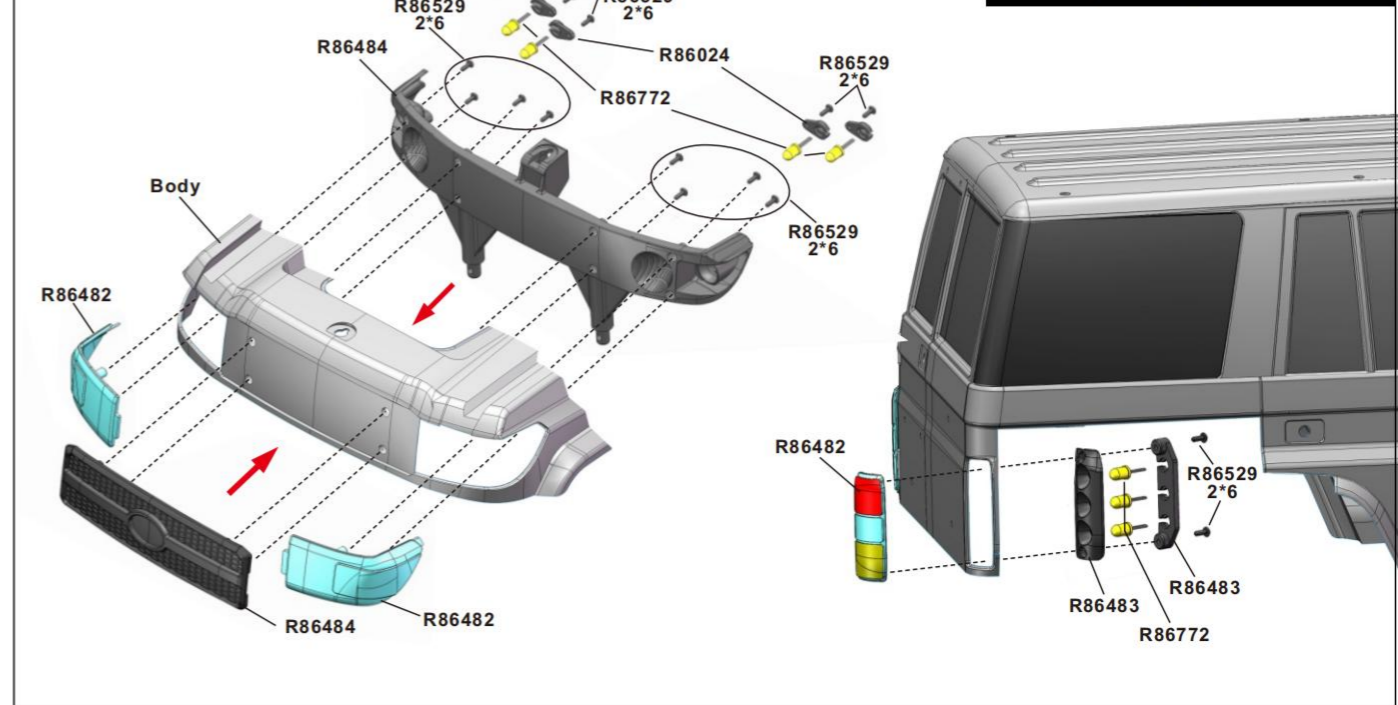

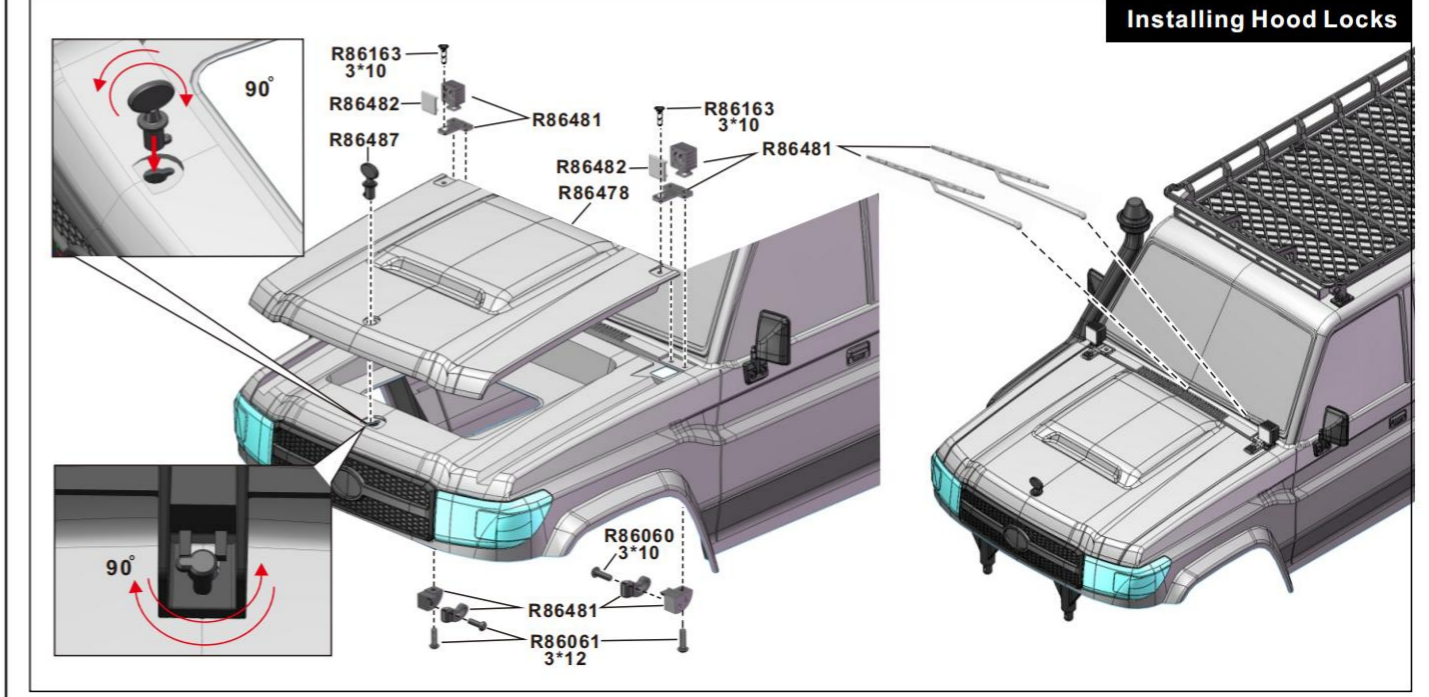
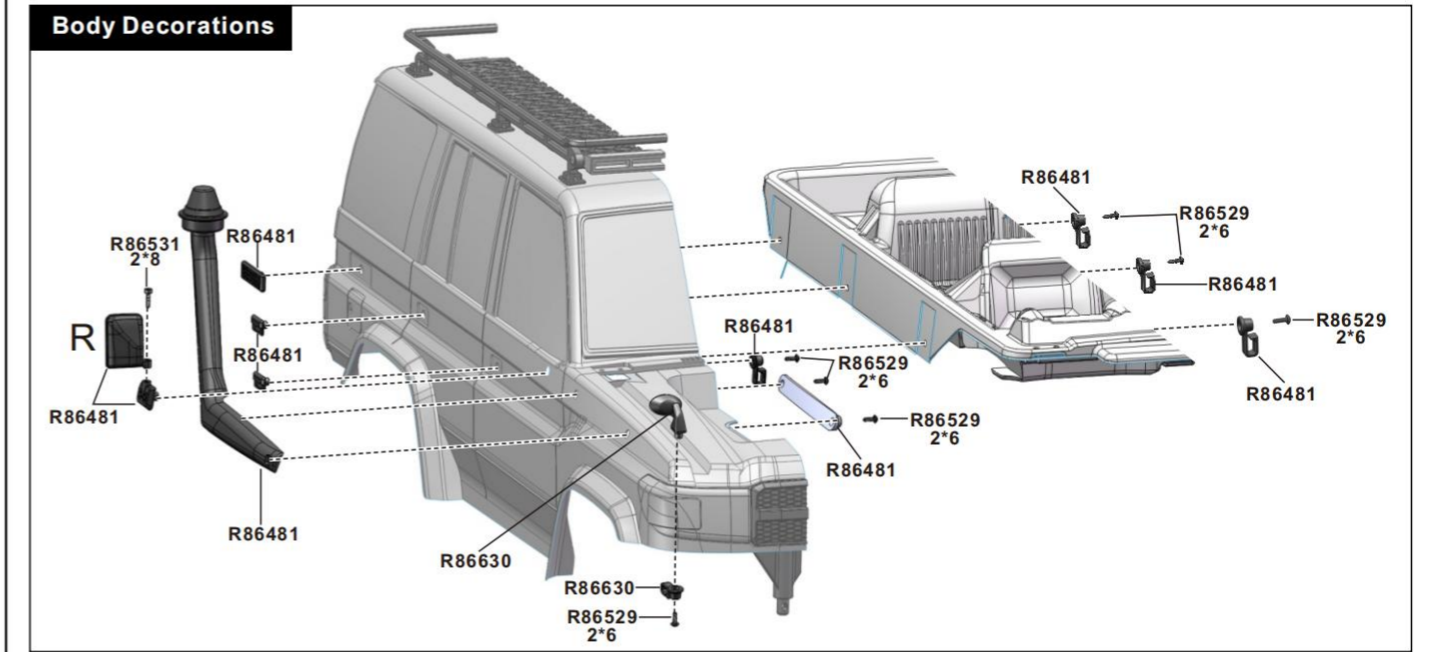
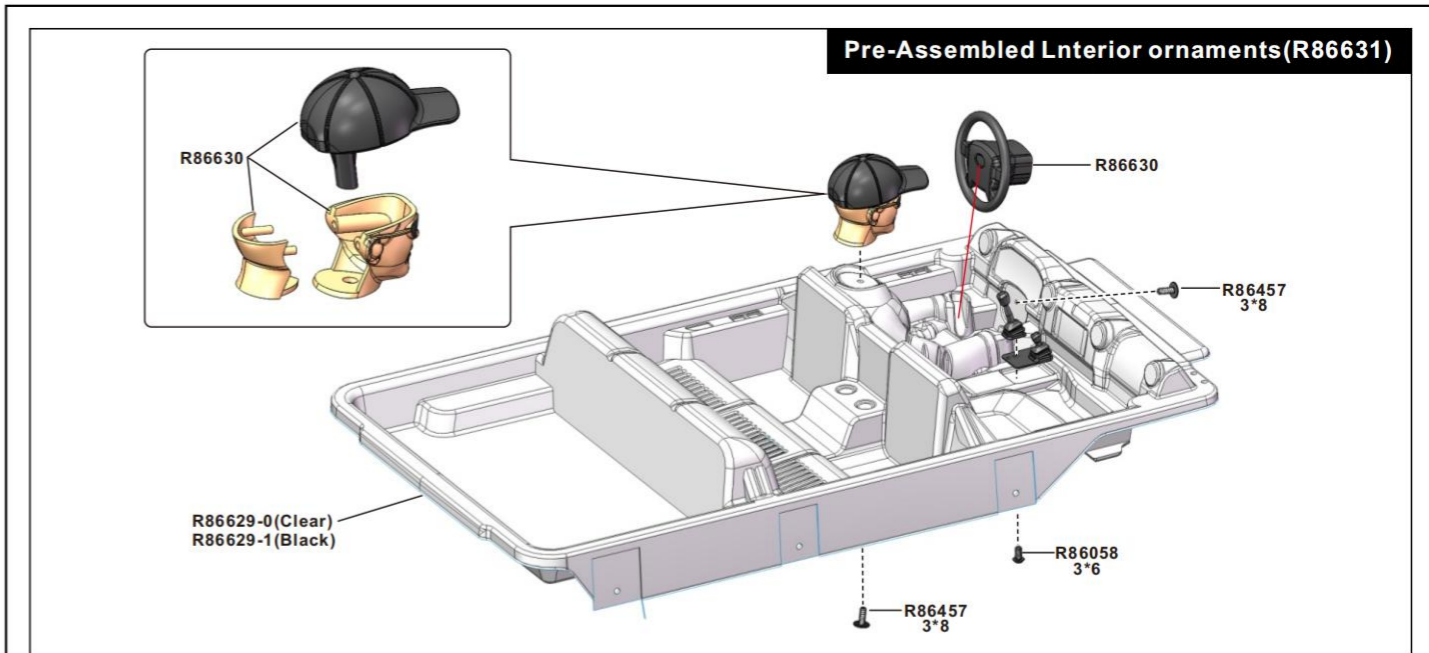
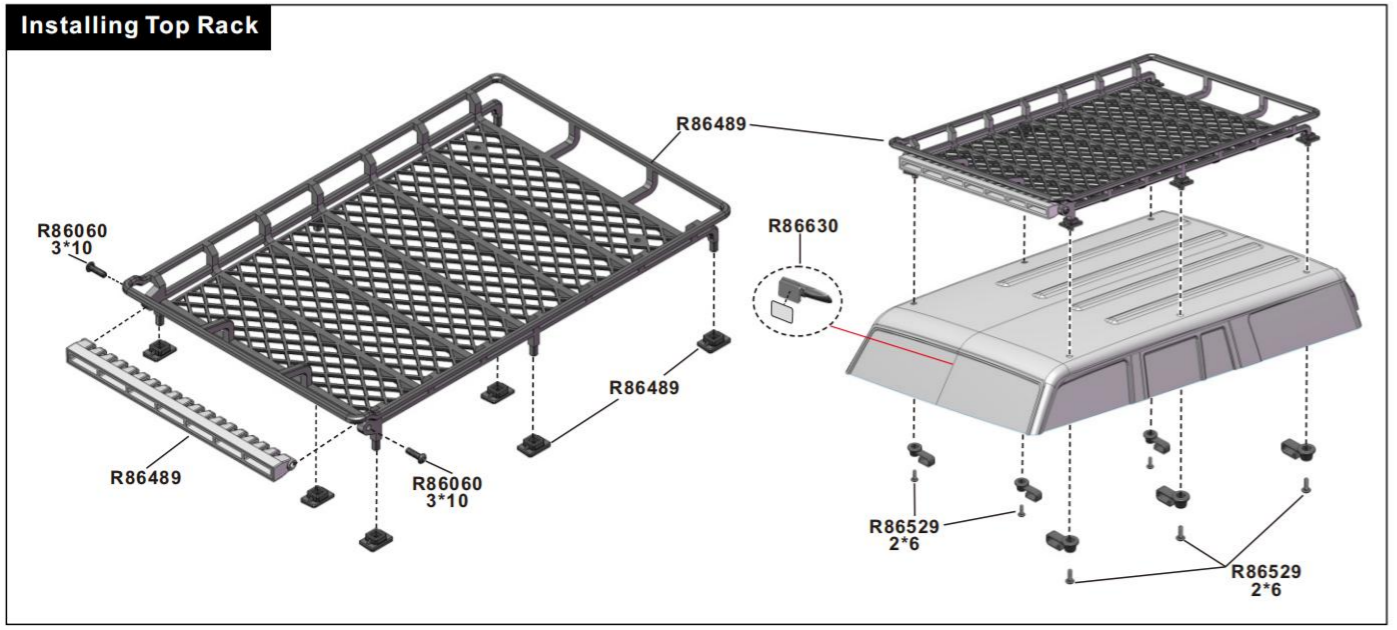
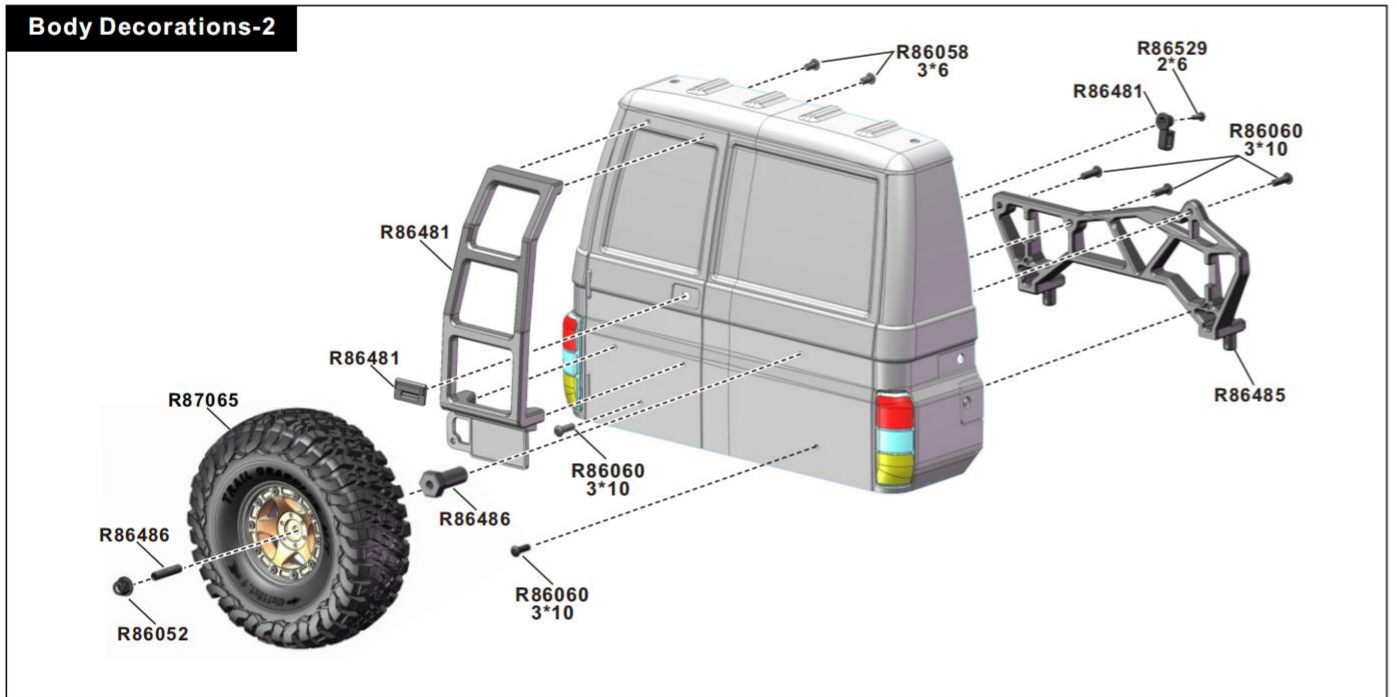
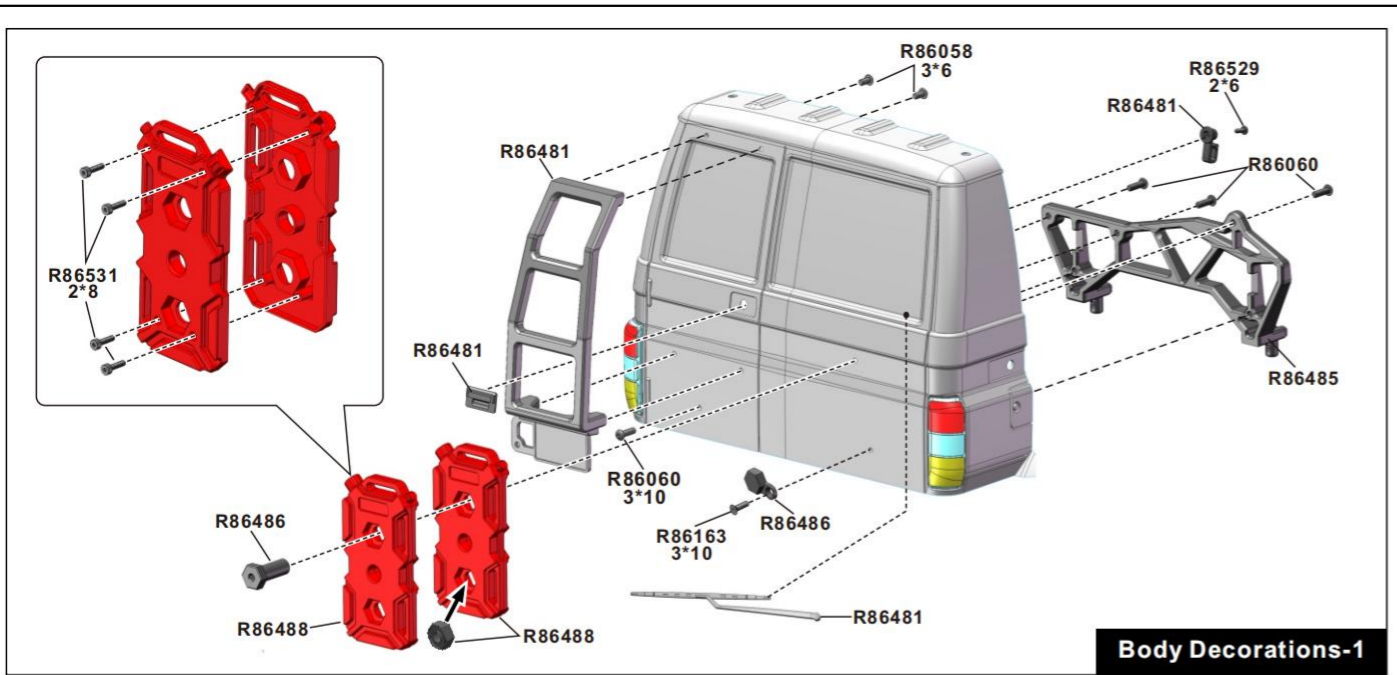

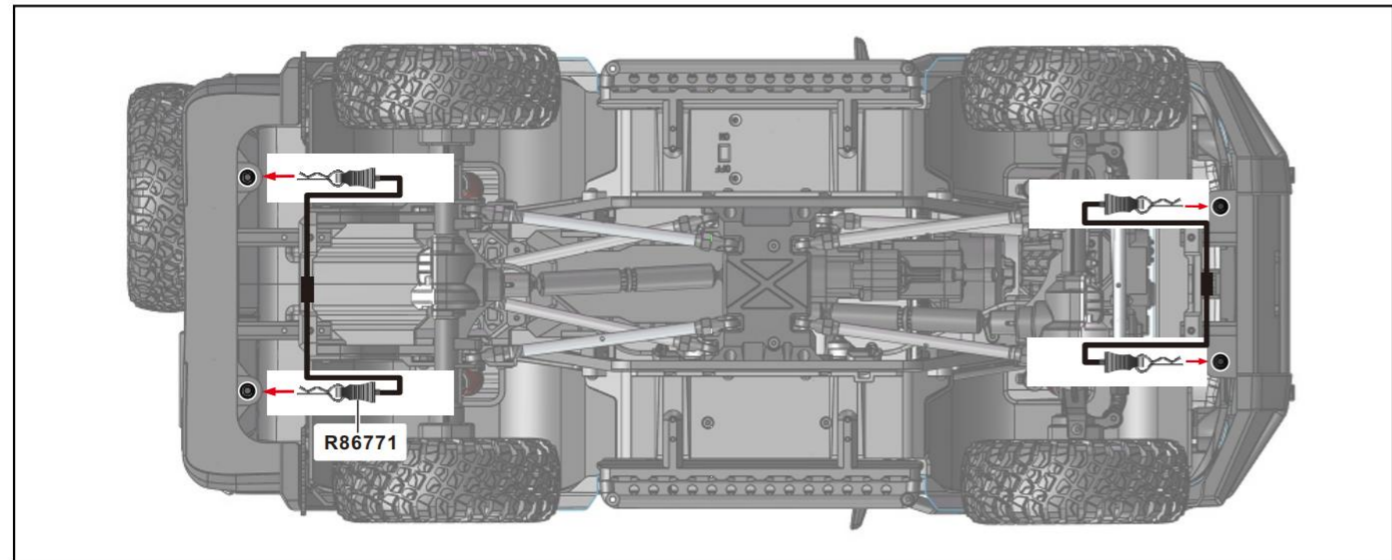
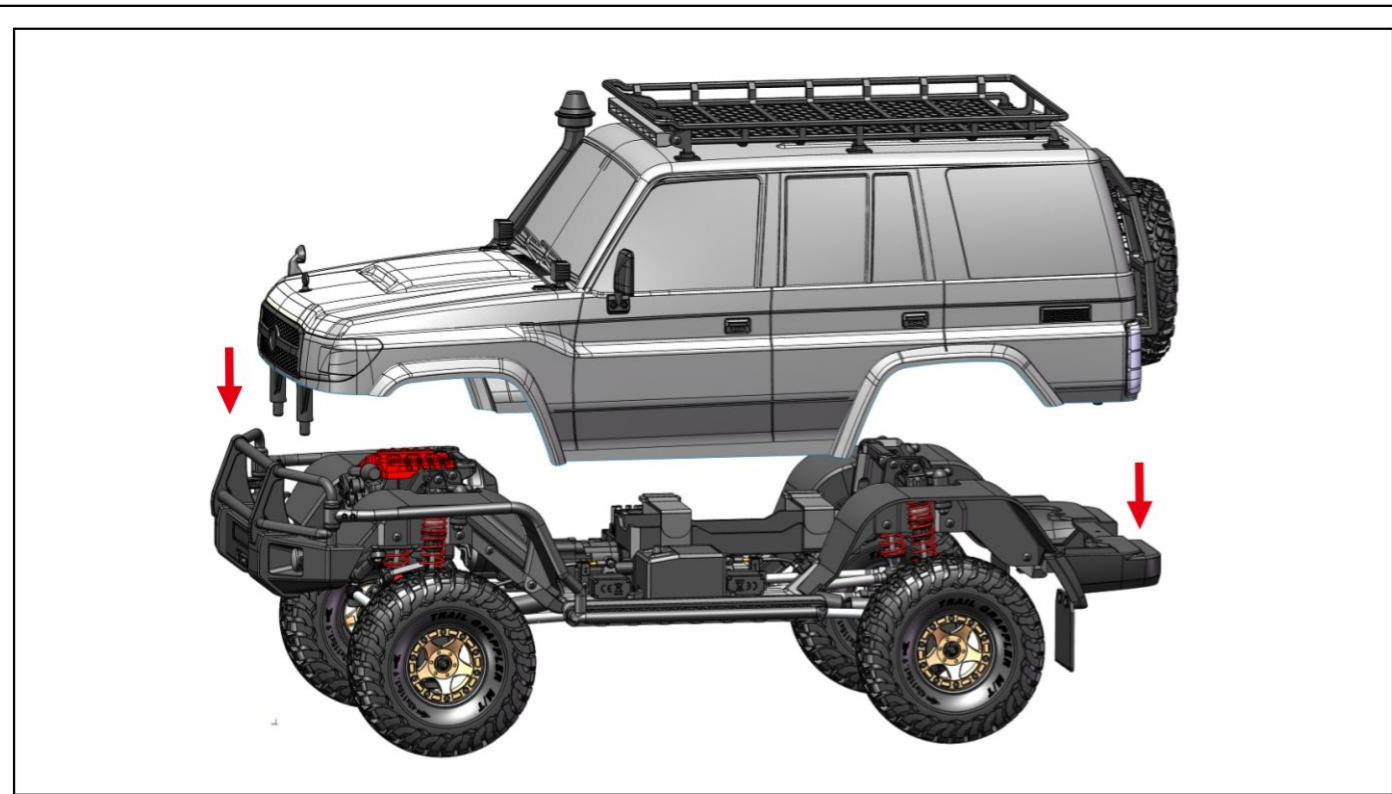







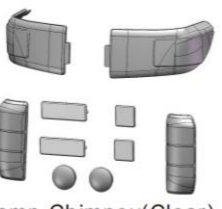





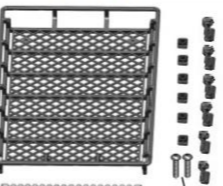



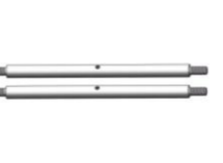
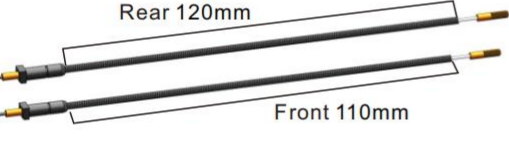







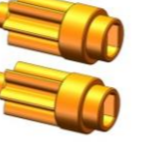





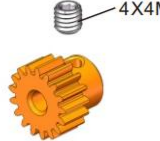







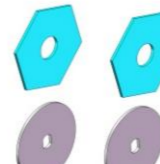







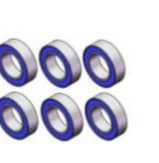

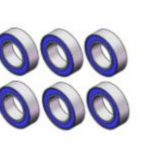
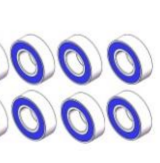
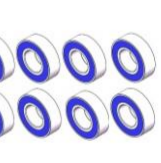











Spare Part

R86545  Front Bumper	R86546  Rear Bumper	R86547  Bumper Mount	R86548  Front Housing	R86549  Rear Housing
R86550  Steering HubCarriers	R86551  Transmission Housing Lid	R86884  (electroplate) Front Gear Box Lid	R86885  (electroplate) Rear Gear Box Lid	R86554  Baffle A(L/R)

Spare Part				
R86555  Shock Plate(L/R)	R86556  Baffle B(L/R)	R86557  Foot Pedal	R86558  Battery Tray	R86559  Body Mount(F/R)
R86560  Motor Mount		R86561  Transmission Box B		R86562  Bumper
R86563  Servo Mount	R86564  Motor Cover Upper	R86565  Motor Cover Front	R86566  Caster Mount	R86567  Chassis Mount
R86468  Receiver Box	R86469  Lock Diff Button	R86470  Differential Box	R86471  35.5mm Front Driveshaft	R86472  41.5mm Rear Driveshaft
R86473  Dig Servo Parts		R86474  Link Ends		R86475  Shock Absorbers
R86631  Pre-Assembled Interior ornaments		PVC Cockpit+Sticker  R86629-0(Clear) R86629-1(Black)		R86630 
PC Body+Sticker  R86479 (Clear) R86480-1(Black) R86480-5(Silver Grey) R86480-6(Royal Blue)		Pre-Assembled PC Body  P86480-1(Black) P86480-5(Silver Grey) P86480-6(Royal Blue)		R86478  PC Body Hood(Clear)

Spare Part				
R86481  Body Assembled Part	R86482  Lamp-Chimney(Clear)	R86483  Lamp-Socket(Rear)	R86484  Air Grill / Lamp-Socket(Front)	
R86485  Rear Body Plate	R86486  Rear View Mirror	R86487  Hood Switch	R86488  Tank	R86489  Roof Rack
R86490  Chassis Rails	R86491  Panhard Bar Link	R86492  Link 72.5mm	R86493  Link 100mm	
R86497  Front/Rear Lock Diff Line	R86494  Link 108mm	R86495  Link 110.5mm	R86496  Link 113mm	
R86498  Diff Main Gear(40T)	R86499  Drive Gear(16T)	R86500  Diff Bevel Gear Set	R86501  Transmission Gear(9T)	R86502  Transmission Gear(6T)
R86503  Transmission Gear(20T)	R86504  Transmission Gear(17T)	R86505  Transmission Gear(13T)	R86506  Transmission Slider	R86507  Gear Stick
R86508  Pinion Gear(17T)	R86509  CVD Drive shaft	R86510  Rear shaft	R86511  Driveshaft	R86512  Gear Shaft 1

Spare Part				
R86749  Crown Gear (64T)	R86187  Sping	R86514  Slipper Spacer/Plate	R86515  Differential Lock	R86516  Gear Shaft 2
R86517  Gear Shaft 3	R86518  Gear Shaft 4	R86519  Gear Shaft 5	R86520  Ball Bearing Ø15*Ø21*4	R86521  Ball Bearing Ø12*Ø18*4
R86522  Ball Bearing Ø10*Ø15*4	R86523  Ball Bearing Ø7*Ø14*4	R86524  Ball Bearing Ø7*Ø11*3	R86525  Ball Bearing Ø5*Ø11*4	R86526  Ball Bearing Ø4*Ø8*3
R86045  King Pin Bushing	R86527  Ball Stand Ø 4mm	R86048  Ball Stand Ø 5.9mm	R86052  Flange M4 Lock Nut	R86528  Nylon Nut M2.5
R86379  Button Head 2*4mm	R86058  Button Head 3*6mm	R86059  Button Head 3*8mm	R86060  Button Head 3*10mm	R86061  Button Head 3*12mm
R86062  Button Head 3*14mm	R86065  Button Head 3*20mm	R86066  Button Head 3*25mm	R86529  Button Head Self-tapping 2*6mm	R86530  Step Screws 4*11.5mm
R86071  Cap Head 2.5*8mm	R86531  Cap Head Self-tapping 2*8mm	R86532  Flat Head 3*6mm	R86072  Flat Head 2.5*10mm	R86163  Flat Head 3*10mm

Spare Part				
R86533  Crub Screw Bolt 3*18mm	R86568  Shock Shaft	R86534  O Ring 2.8*1.9mm*8P O Ring 2.8*2.0mm*8P O Ring 10*1mm*4P	R86535  E-Clips - ϕ 2.5mm*6P E-Clips - ϕ 4mm*6P	R86536  Pin -2*10mm*6P Pin -2*11mm*6P Pin -2*12mm*6P
R86537  ϕ 2.6* ϕ 6*0.5 Metal Washer	R86569  Wheel Hex	R86539  Dig Servo 9G 7.4V	R86540  Steering Servo 25KG	R86541  Servo Horn(25T)
R86538  Motor-550/8020	X8E(GS07)-150  Radio/Receiver	X6DC  Receiver	R86772  Light	R86769  Magnetic Adapter Cable
R86771  Body Clip Mount	R86024  Light Clip	R86900  ESC -80A	R86457  Flange Head Screws 3*8	R86477  Rear Fender
R86633  Pre-Assembled Housing	R86788  Tire W/Foam	R87064  Wheel Rim	R87065  Wheel Complete L/R	

Upgradable Optionals				
R86366  Adjustable LED Lamp	R86544  PVC Rain Shield	P860079  Adjustable LED Lamp		
P860077  Adjustable LED Lamp	P860065  Wheel (AL.)	P860066  Wheel (AL.)	P860094  Copper Wheel Weight Set 128g	
P860086  Steering Hub Carriers (AL.)	P860087  Transmission Housing Lid (COPPER)	P860088  Shock Plate(L/R) (AL.)	P860089  Chassis Mount (AL.)	P860090  Differential Box (AL.)
P860091  Front Gear Box Lid (COPPER)	P860092  Rear Gear Box Lid (COPPER)	P860093  Motor Mount (AL.)	R86570  Wheel Rim	R86571  Crawler Battery (7.4V 6200mAh/Plug:T)
R86601  Antenna Pole	R86612  Drive Axle	R86770  9g/7.4v servo with metal gear	P860102  Hood Switch	R86513  Crown Gear (64T)
R86439  Wheel Rim(Gun Gray)	R86466  Tire W/Foam	R86476  Wheel Complete L/R (Gun Gray)	R86773  Wheel Rim(Black)	R86774  Wheel Complete L/R(Black)
R86808  Body Decal Stickers	R87066  Lace Decals + Decorative Stickers			