



USER MANUAL OFF-ROAD CRAWLER NO.:EX86100V3



ROCK CRAWLER



WARNING:

This product is only for 14 years old or above

Notes:

- ↳ Read and understand the instructions carefully before operating or assembling your racing model.
- ↳ Specifications are subject to change without prior notice, and actual received model may vary from the images and/or descriptions in this manual.

Remote control models are specialized and high-value products. If you identify any quality defects upon receipt, please do not use the product and contact the seller immediately to arrange a replacement or return. Please note that we cannot provide any after-sales guarantee for damages which are caused by improper use.

The product conforms to technical requirements of export safety regulations.



Please read and follow all the instructions in the manual before use.

MADE IN CHINA

Factory Address: Dong Guan City, Guang Dong Province, China

Production Date: refer to packing instruction



Introduction

We would like to welcome you to the world of remote control cars. What are RC cars? The simple answer is that they are radio controlled cars that respond precisely to your command. The more complete answer is that they can be a great addition to your lifestyle. RC car building and racing teach valuable mechanical and electrical skills, promote teamwork and encourage racers to test their skills with other racers from around the world. Whether you are just having fun racing your car in your backyard or racing at the world competition contest, radio controlled car racing is a great hobby.

We have been making RC products aimed at making our hobby fun and exciting with an affordable price. We are confident that your experience with our products will be positive. Of all the radio controlled models out there, no question about it, RC cars are the hardest to operate. This user manual covers a wide range of topics from nitro powered remote control cars to electrical powered remote control cars. We highly recommend that you read this user manual thoroughly and carefully before assembling and operating. Please follow all precautions and recommendations located within the manual. Be sure to retain the manual for future reference, routine maintenance, and tuning.



This product is not a toy. It is not recommended for children under 14 years old and any minor should be accompanied by an adult when operating. This product is a precision machine that requires proper assembly and setup to avoid accidents. Failure to take caution when operating this product may result in serious injury or property damage. It is the owner's responsibility to operate this product in a safe manner. Manufacturer and its distributors are not responsible in any way for any and all bodily injury(s) and/or property damage that may occur from the use of or caused by in any way of this product.



Warnings

- The product is not intended for those under 14 years of age without proper adult supervision. The product is not a toy. It is a precision machine requiring proper assembly and setup to avoid accidents and it is the responsibility of the owner to operate this product in a safe manner as it can cause serious personal injury and damage to property due to carelessness or misuse.
- Do not attempt to disassemble or modify any of the product components without the assistance of an experienced RC user.
- Only use the correct type of battery to operate. Using any wrong type of battery will damage the product and possibly make it dangerous to operate.
- The motor(s) may get hot during use. Always allow the motor 10 - 15 minutes to cool down between each operation. This will prolong the life of your product.
- Choose an appropriate operating site consisting of flat, smooth ground, and clear open field. Do not operate near buildings, high voltage cable lines, or trees to ensure safety operation. Operate in safe area only, away from other people. RC models are prone to accidents, failures, and crashes due to a variety of reasons including, lack of maintenance, user error, and radio interference. Users are responsible for their actions and damage or injury occurring during the operation.
- Do not operate in inclement weather, such as rain, wind, snow or darkness.
- The product, composed of precision electrical components, must be kept away from moisture and other contaminants. Do not allow them to get wet. Electrical damage may occur that could affect safe operation.
- You should complete a successful pre-run check of your radio equipment and the model prior to each run.
- Use replacement parts from the original manufacturer to ensure safe product operation.
- Operate this product within your ability. Do not operate under tired condition.
- After each use, always allow the battery to cool down before recharging. When charging the battery pack, do not overcharge! If batteries get hot during charging, discontinue charging immediately and disconnect the battery from the charger. Never leave battery unattended while charging. If you are unsure of how to charge this battery, please seek the advice of experienced RC users. Never let children charge the battery without adult supervision.
- Always turn on the transmitter before connecting the battery on the model. When turning off the model, always disconnect the battery first, and then turn off the transmitter. If the order is reversed, the model may become uncontrollable and cause serious damage.
- If you are in doubt about your ability to operate the model, we strongly recommend that you seek assistance from experienced RC users or join your local modeling club to gain the required knowledge and skill. As the manufacturer and distributor, we assume no liability for the use of this product.
- Before turning on your model and transmitter, please check to make sure no one else is operating under the same frequency. Frequency interference can cause your model, or other's models to crash. The guidance provided by experienced RC users will be valuable for the assembly, tuning, trimming, and actual first flight.
- Never allow batteries to run low or you might lose control of the model.
- Plastic is very susceptible to damage or deformation due to extreme heat and cold climate. Do not store the model near any source of heat such as oven or heater. Store the model indoors, in a climate-controlled, room temperature environment.
- Never shorten the receiver antenna; or this might affect the transmitting range of the radio system.
- This product is a RC hobby model, do not use for other purpose.

Safety

Pay close attention to the following symbols and their meanings. Failure to follow these warnings could cause damage, injury or death.

 Danger	Not following these instructions may lead to serious injuries or death.
 Warning	Not following these instructions may lead to major injuries.
 Attention	Not following these instructions may lead to minor injuries.

 Prohibited	<ul style="list-style-type: none"> ■ Do not use the product at night or in bad weather like rain or thunderstorm. It can cause erratic operation or loss of control. ■ Do not use the product when visibility is limited. ■ Do not use the product on rain or snow days. Any exposure to moisture (water or snow) may cause erratic operation or loss of control. ■ Interference may cause loss of control. To ensure the safety of you and others, do not operate in the following places: <ul style="list-style-type: none"> ● Near any site where other radio control activity may occur ● Near power lines or communication broadcasting antennas ● Near people or roads ● On any body of water when passenger boats are present ■ Do not use this product when you are tired, uncomfortable, or under the influence of alcohol or drugs. Doing so may cause serious injury to yourself or others. ■ The 2.4GHz radio band is limited to the line of sight. Always keep your model in sight as a large object can block the RF signal and lead to loss of control. ■ Do not touch any part of the model that may generate heat during operation, or immediately after use. The engine, motor or speed control, may be very hot and can cause serious burns.
 Mandatory	<ul style="list-style-type: none"> ■ Misuse of this product may lead to serious injury or death. To ensure the safety of you and your equipment, read this manual and follow the instructions. ■ Make sure the product is properly installed in your model. Failure to do so may result in serious injury. ■ Make sure to disconnect the receiver battery before turning of the transmitter. Failure to do so may lead to unintended battery issues or an accident. ■ Ensure that all motors operate in the correct direction. If not, adjust the direction first. ■ Make sure the model stays within the radio maximum signal range to prevent loss of control during operation.

Thanks for purchasing our RC car. Since the power system of the RC model can be very dangerous, please read this manual carefully. Since we have no control over the correct use, installation, application, or maintenance of our products, we shall assume no liability for any damages, losses or costs resulting from the use of this product. Any claims arising from the operating, failure of malfunctioning etc. will be denied. We assume no liability for personal injury, consequential damages resulting from our product or our workmanship.



START GUIDE

1. Challenger Specifications

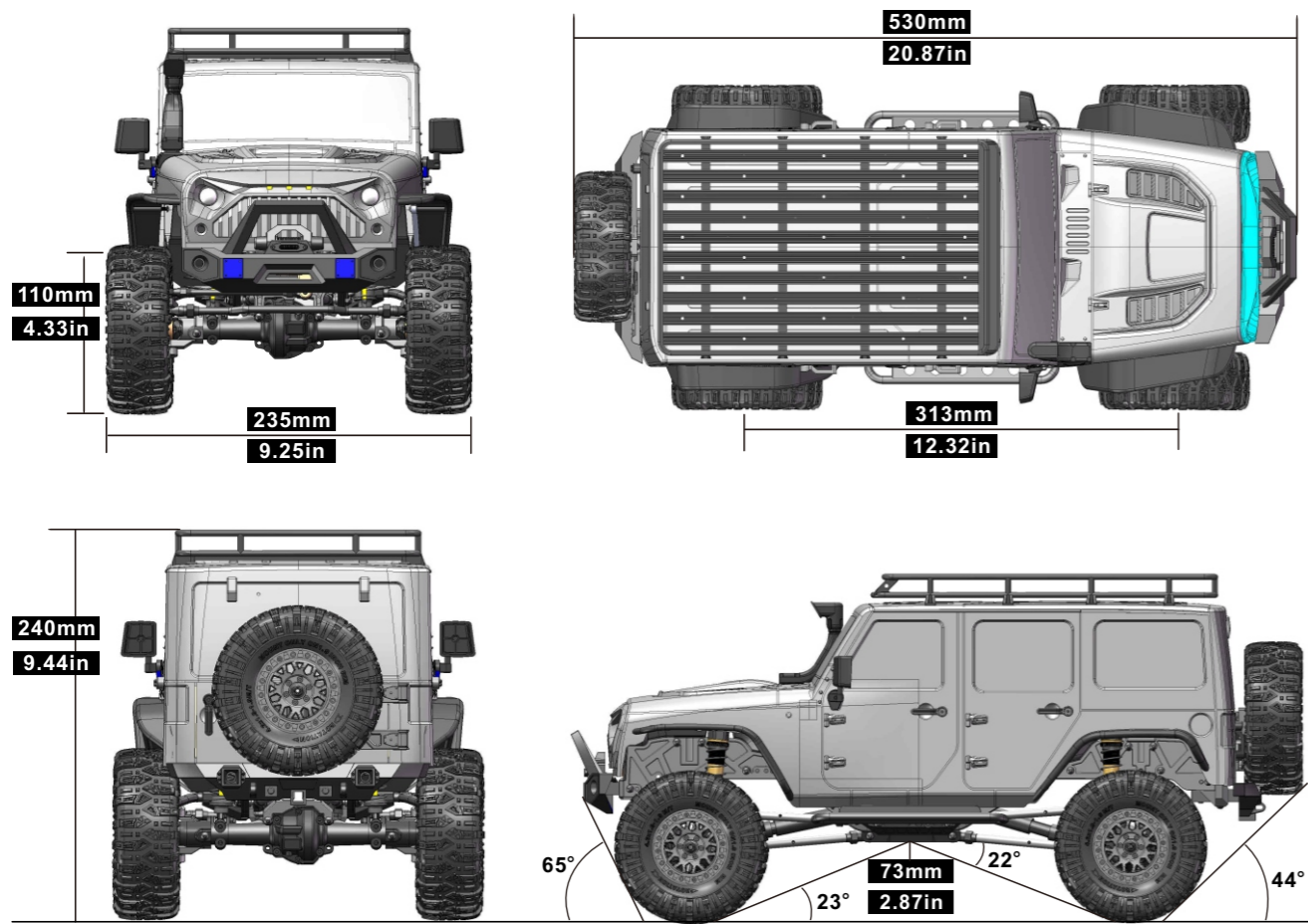

Item NO	EX86100V3	Wheel Base	313mm	Motor	8020-RC550-20T,/14T
Item Name	Rock Cruiser	Wheel	110*40mm	Breakover	23°
Scale	1/10	Clearance	73mm (chassis) 35mm (steel)	Approach	65°
Description	Crawler/Off-Road	Weight	2.88kg(No Battery)	Departure	44°
Drive Mode	4WD	Radio	2.4G/6CH	Gift Box Size	575*275*282mm
Length	530mm	ESC/RX	WP-1040/40A	Body Type	Soft/PC1.2
Width	235mm	Battery	2S-3S Lipo Recommendations	Body Color	Grey/Orange/Red
Height	240mm	Steering Servo	Digit Metal Gear-15KG	Piece per Carton	2P

2. Please read the manual carefully and prepare the following things before use.

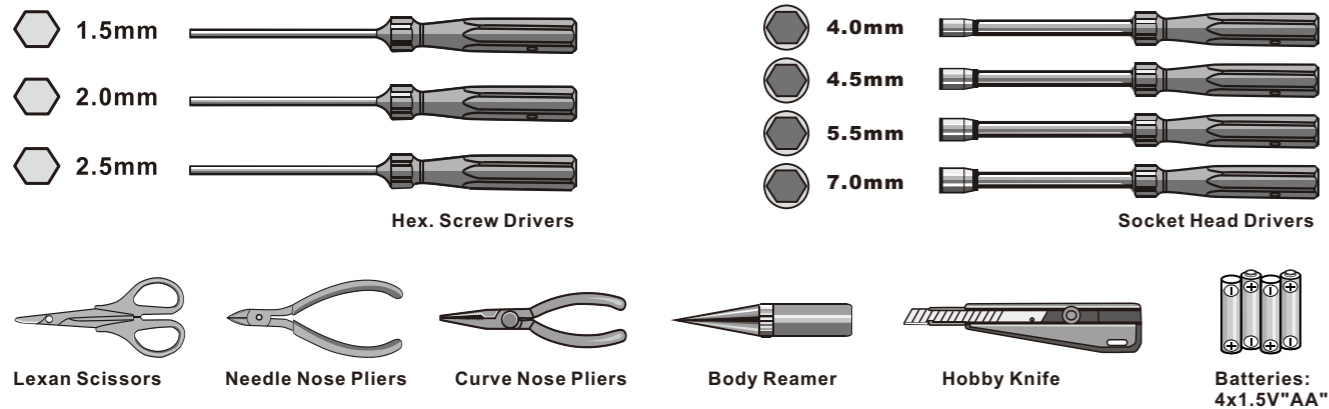

3. The items inside the box.



4. Please check the whole product condition when open the package.

- 3-1. After each day of running, you should check your shocks for adequate fluid. If the fluid is low, or it is getting dirty, you should change the fluid in the shocks. To achieve better performance, you may also want to change the shock fluid and or the pistons.
- 3-2. Gear mesh is the clearance between the pinion and spur in an electric car or clutch bell and spur in a nitro car. It has impact on the vehicles performance. If the gear mesh is not set properly you may also damage the clutch bell and spur or the pinion gear and spur gear as soon as the vehicle starts running.
- 3-3. Please check if the screw is tight enough before use. Screw it tight (or apply the screw glue if necessary)
- 3-4. Regularly check and verify the tires are intact. No breach should be observed. Please apply the CA glue if needed.



5-1. Scheme of installation

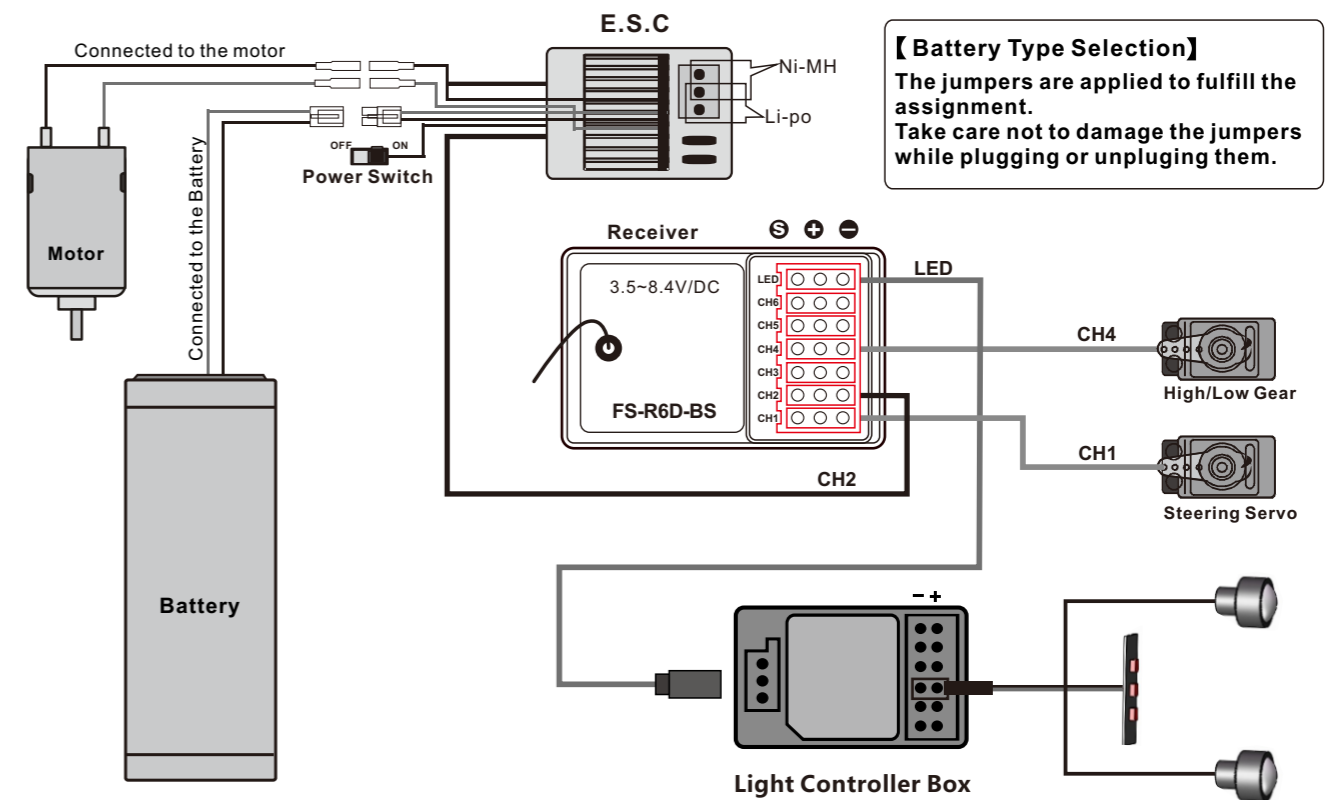

5-2. Battery Specifications for Product

WARNING:

NO battery includes in factory. Recommend? battery: 2S~3S LIPO battery or 5-9 cells NIMH battery (please match the ESC mode with the corresponding battery type) Pay attention to the battery size and plug specification when purchasing. The maximum battery measurement is 142*48*55mm JLxWxH).

This product can use the 2S or 3S Li-Po battery.

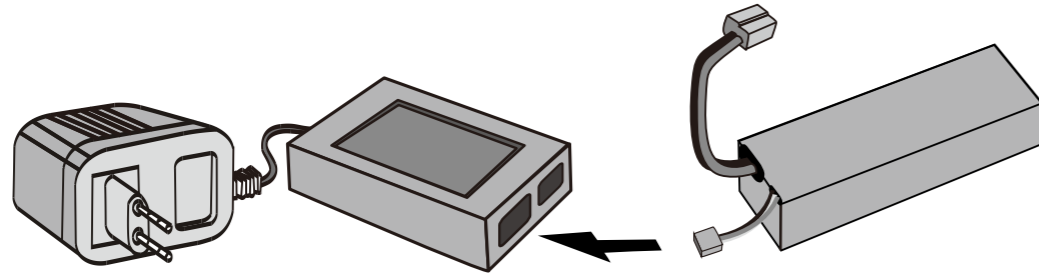

NOTICE

Please check the battery voltage before use. Please use a qualified charger to charge the newly purchased battery. (please read the charging steps in manual when necessary)

Charge the vehicle battery

- Connect charger plug with mains jack and then connect with connector of battery.
- Please be care of safety while charging, please remove charger plug from the mains jack once finish charging. will be over heat if it is too long to be charging or incorrect charging way. must stop charging if over 45 degree for the battery temperature.
- Do not charge for battery at once when you take it away from your car. Please make sure battery in cool condition before recharge battery to keep battery performance running well and get a longer use life.

Lithium Polymer (LiPo) Battery Warnings

- Never charge a lithium polymer battery with a charger designed for NiCd, NiMH, or any other type of battery chemistry. Use ONLY charger designed for LiPo battery.
- Do not leave LiPo battery unattended during charging.
- Do not overcharge the battery.
- Always place the battery on a heat resistant surface alone when charging.
- Always put the LiPo battery inside a charging protection container while charging.
- Do not allow LiPo cells to overheat at any time. Cells which reach greater than 140 Fahrenheit (60°C) will usually become damaged and will catch fire.
- Do not charge LiPo cells on or near combustible materials including paper, plastic, carpets, vinyl, leather, and wood. inside an R/C model or full size automobile.
- Do not discharge LiPo; doing so will damage the battery.
- Do not expose LiPo cell to water or moisture at any time.
- Do not store battery near open flame or heater.
- Do not assemble LiPo cells or pre-assembled packs together with other LiPo cells or packs.
- Always store LiPo battery in a secure location away from children.
- Always remove the LiPo battery if model is involved in any kind of crash. Carefully inspect the battery and connectors for even the smallest damage. **CAUTION: cells may be hot!**
- Do not allow the electrolyte to get into eyes or on skin. Wash affected areas immediately if they come into contact with electrolyte. Do not alter or modify connectors or wires of a LiPo battery pack.
- Always inspect the condition of the battery before charging and operating.
- Do not short circuit the LiPo battery.
- Do not have contact with a leaky/damaged battery directly.
- Do not charge battery out of recommended temperature range (0°C -45°C)

6-1. 2.4GHZ Radio System

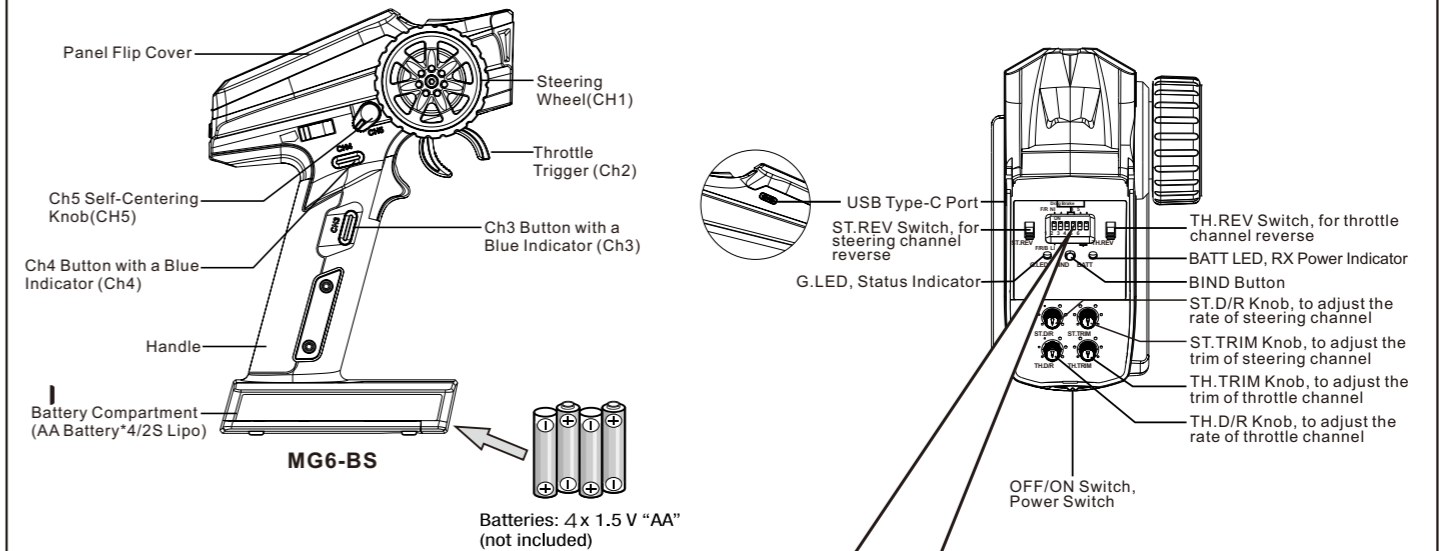

6-bit DIP Switch

Running Mode

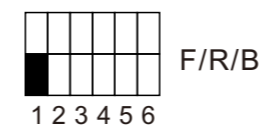
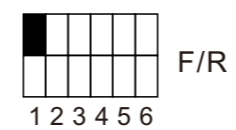

Battery Type

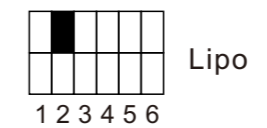
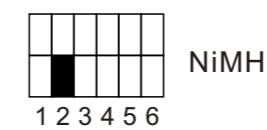

Drag Brake

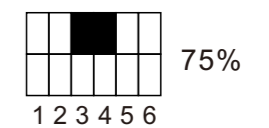
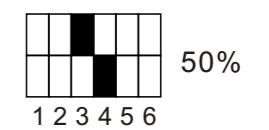
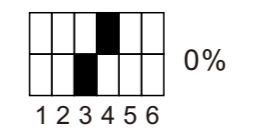
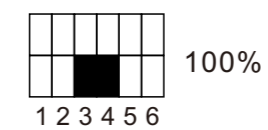

The ESC parameters can be set by the 6-bit DIP Switch of the transmitter, that is, the DIP switch is located at different positions and the corresponding parameter values are different. There are three parameters can be set for the ESC, which are "Running Mode", "Battery Type" and "Drag Brake".

Running Mode

• Forward/Reverse/Brake(F/R): This mode adopts "double click" reverse mode, that is, when the throttle trigger is pushed from neutral range to the reverse area for the first time, the motor is only braking and will not reverse; when the throttle trigger is moved back to the neutral range and pushed to the reverse area for the second time, it will reverse. This mode is applicable to general models.

• Forward/Reverse(F/R): This mode adopts "one click" reverse mode, that is, when the throttle trigger is pushed from neutral range to the reverse area, the motor immediately generates reverse action, which is generally applied to rock crawler.

• The switch marked 1 of the 6-bit DIP switch is used to set the ESC running mode. The switch on the upper position indicates that the running mode is Forward/Reverse; and the switch on the lower position indicates that the running mode is Forward/Reverse/Brake.

Setup:

Toggle the switch 1 to the upper position, the buzzer will have one beep. Toggle the switch to the lower position, the buzzer will have two beeps.

Battery Type

• There are LiPo and NiMH cells. It can be set according to the actual use.

• The switch 2 of the 6-bit DIP switch is used to set the battery type. The switch on the upper side indicates that the battery type is LiPo; and the switch on the lower side indicates that the battery type is NiMH cells.

Setup:

Toggle the switch 2 to the upper position, the buzzer will have one beep. Toggle the switch to the lower position, the buzzer will have two beeps.

Drag Brake

• The drag brake means that when the throttle trigger moves from the forward or reverse area to neutral range, it will produce certain braking force to the motor, the larger the value is, the greater the drag brake force is. And this is applicable to decelerate into a turn and model crawler applications. Select proper braking force according to the actual situation.

• The switches 3 and 4 of the 6-bit DIP switch are used to set the ESC drag brake force. The drag brake force can be set to 0%, 50%, 75% or 100%.

Setup:

• Toggle the switch 3 to the lower position and switch 4 to the upper position, then the drag brake force is set to 0%.

• Toggle the switch 3 to the upper position and switch 4 to the lower position, then the drag brake force is set to 50%.

• Toggle both the switch 3 and 4 to the upper position, then the drag brake force is set to 75%.

• Toggle both the switch 3 and 4 to the lower position, then the drag brake force is set to 100%.

6-2. Transmitter Steering and Throttle Instruction

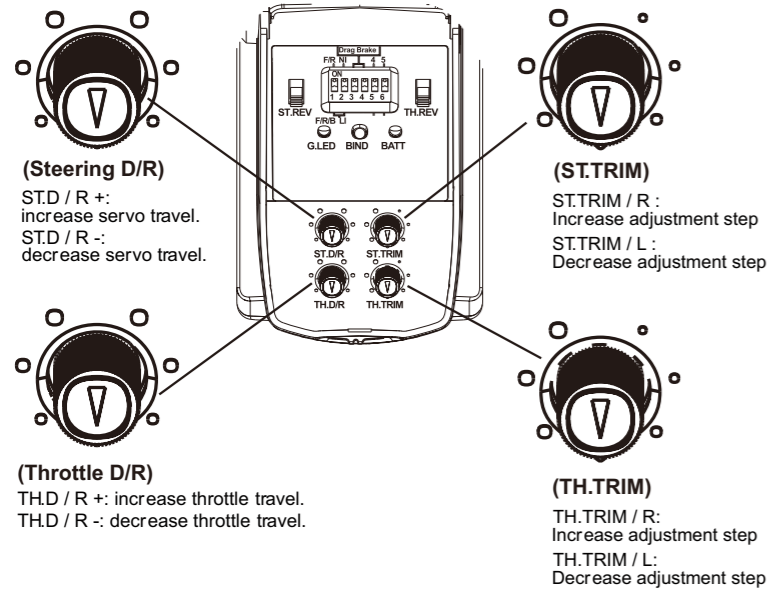

Note:

- Please trim the throttle (TH.Trim) until the vehicle does not move forward or backward automatically when first activated.
- ST.TRIM is the trims for CH1 (Steering), and use it to achieve the desired steering angle.
- ST.D/R is for servo travel adjustment and can be multiplexed as trims of CH1 (Steering).
- TH.D/R is for throttle travel adjustment and can be multiplexed as trims of CH2 (Throttle).

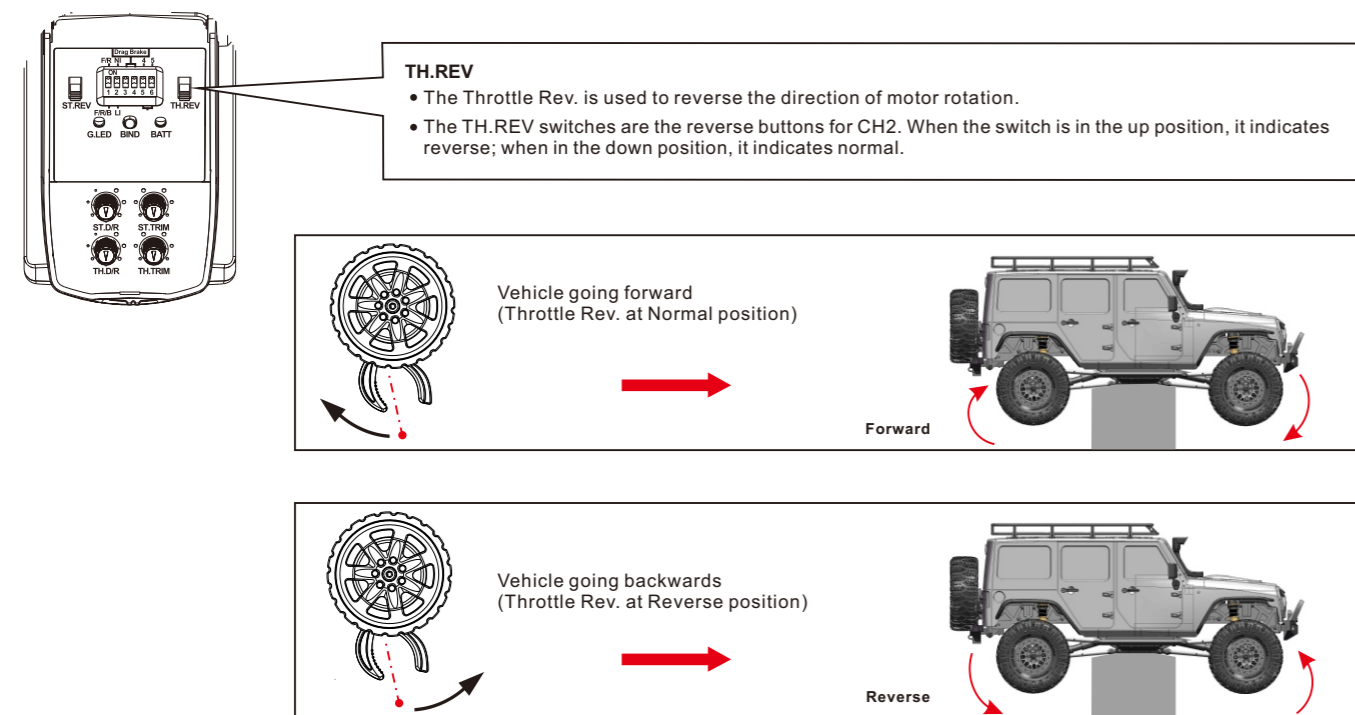
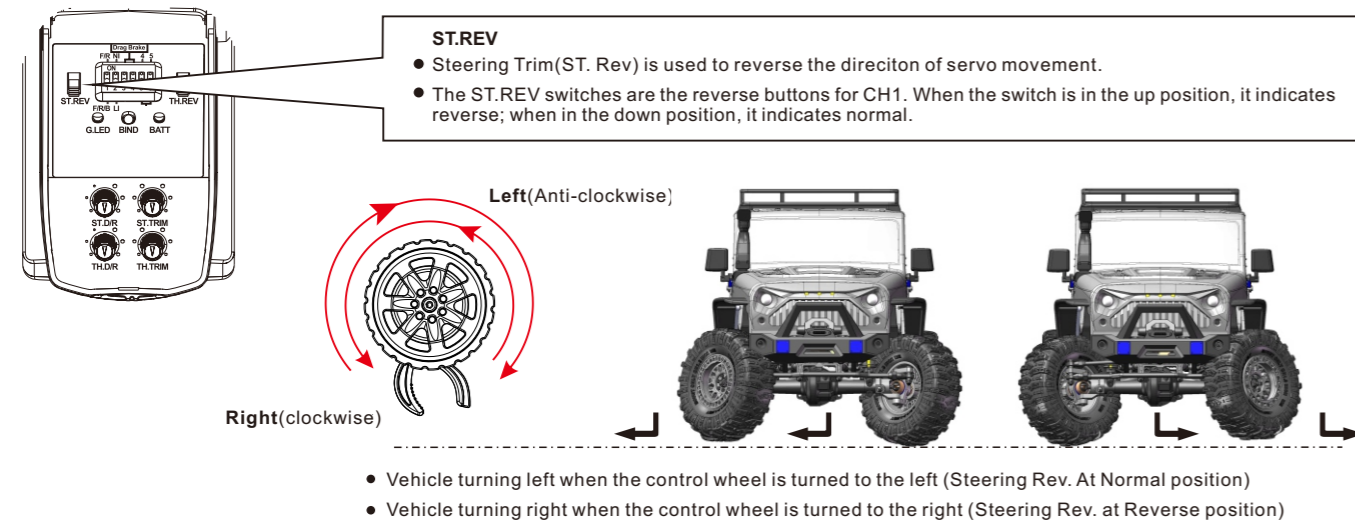

7-1. Transmitter Steering Trim and Throttle Trim

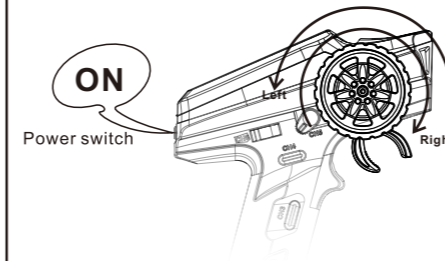

1. Move the control wheel to the left, vehicle turns left.
2. Do not move the control wheel, the front wheels are aligned and the vehicle goes straight in line.
3. Move the control wheel to the right, vehicle turns right.

⚠ Note

Place the Vehicle on the stand with four wheels off ground as shown.



Wheel Angle

the maximum rotation of the Steering wheel is 35 degrees From center to left or right

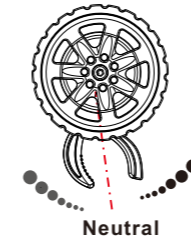

Throttle trigger, has a total throw of 12 degrees, 12.5 degrees forward, and 12.5 degrees backward

The heavier you pull or push the trigger, the faster acceleration will be.

Note: Release the throttle trigger button, activate the brake mode automatically. (Only for Crawler)

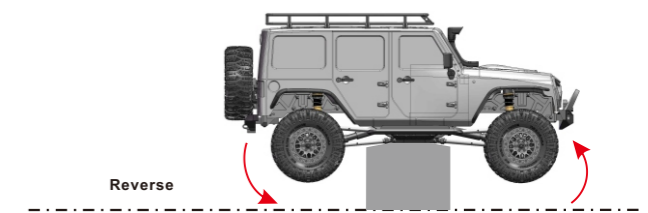
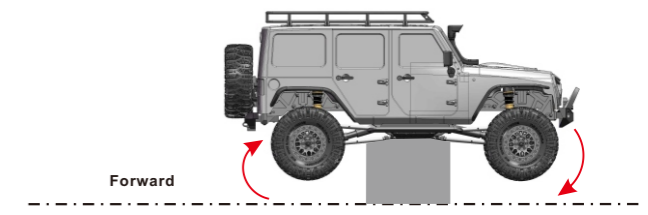
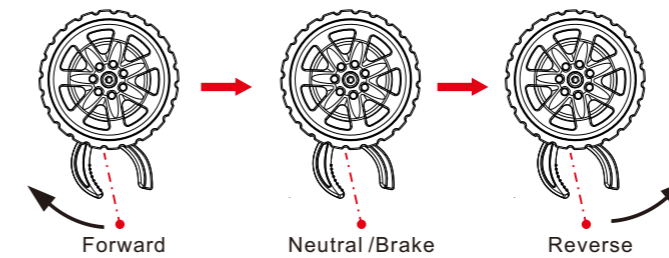

7-2. Light Control Usage

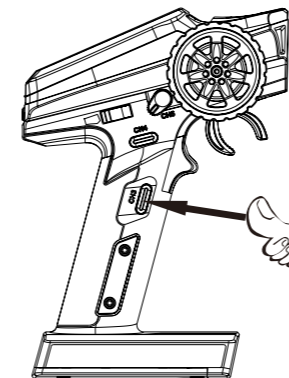

As shown in the picture:
Press the button once, the lights are ON;
Press the button twice, the lights flash;
Press the button three times, the lights are OFF.

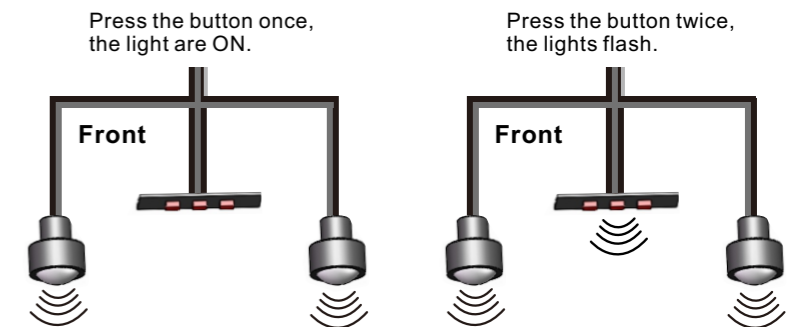

8. All the ways done, your car is ready to run. Hope you enjoy the fun in driving it.

Tip: Always turn off the receiver and then the transmitter when not in use. Clean the car before storage.

Vehicle Maintenance:

- 1). Please remove the batteries from both the vehicle and the transmitter, when the car is out of use for a long time,
- 2). Before each use, please carefully check whether the circuit wires of the model are tight and free of loose connectors. Also, please carefully inspect if the wheels are securely fastened—loose wheels can cause excessive wear to parts such as the drive shaft, wheel cups, or wheel hubs.
- 3). Ensure the unused battery pack should be charged to 50-60% capacity before being stored in a dry and cool place, out of the reach of children.
- 4). After each use, please carefully check if all parts are intact, and repair or replace the worn parts. Use a fine brush to sweep the sand, marl and other dirt inside the model, then wipe it cleanly by a soft cloth.

9. Troubleshooting

Problem	Possible Cause	Solution
Car does not respond during operation	Electronic plugs loose or fall off	Switch off and reconnect
	Vehicle battery not charged, activating the ESC low voltage cut-off to protect the battery	Replace/recharge the vehicle battery
	Motor or ESC dirty or damaged	replace new Motor (recommend to purchase factory Motor)
	ESC failed	replace new ESC (recommend to purchase factory ESC)
	ESC power off by overheated Motor	Stop operation and cool the ESC or Motor
	Motor overheated, demagnetized or damaged	replace new Motor (recommend to purchase factory Motor)
	Transmitter batteries low or beyond the remote control distance	Replace the transmitter batteries, adjust the remote control distance
	Transmitter damaged	Relace or contact seller
No Backward, forward normally	ESC "operation mode" setting error	Refer to manual "ESC" , set "operation mode" into "forward and backward reverse with brake"
	ESC damaged	Relace or contact seller
	Throttle damaged or transmitter throttle not centered	Refer to manual "Transmitter", and reset
Car operate automatically, with no control	Throttle trim out of center on transmitter	Refer to manual "Transmitter", and reset
	Neutral throttle is in incorrect position	Adjust ESC in neutral point
Normal operation, speed shift failure	Error Operation	Ensure to operate in stop status, more refer to the Manual
	Gear Cable damage or loose	Replace the accessory or Readjust
	Servo wire inserts in wrong Receiver slot	Refer to the manual, Readjust
Sluggish Action	Battery damaged / not charged	Check, change or recharge
	Throttle trim out of center on transmitter	Adjust (refer to manual "transmitter")
	Motor dirty/ damaged	Clean/ replace
	Drivetrain dirty / damaged	Check and clean
Light Function Failure after Battery properly installed	Light Plug is not connected or in wrong postion	Check the plug connection
	Transmitter Set Error or Light Control Panel Damage	Reset the Transmitter. Otherwise, please check the light control panel is damaged or not.
	Light Cable in wrong installation and connection	Readjust the installation and Connection
Lack of steering and throttle	ESC power off by overheat	Stop operation, cool the ESC
	Transmitter too near interfere electronical objects	Check and rebind transmitter and receiver, refer to manual
Vehicle moves left / right without steering input	Steering accessories damaged	Check and replace
	Wheel loose	Check and replace
	Drivetrain dirty / damaged	Check and replace
Controls Reversed	ST. REV or TH. REV	Change switch position, refer to manual
	Check the wires between ESC and Motor correct or not	Switch the motor black and red wire
Clicking noise in operation	Check the bodyshell damaged or fall off	Retrim or replace
	Loose or tight between motor gear and main gear	Reset gear mesh
	Gear damaged or rocked	Remove gear cover and inspect. If necessary, replace gear
Only steering, no forward and backward	ESC failed or abnormal	Reset the neutral point or replace
	Transmitter failed or abnormal	Relace or contact seller

Transmission Assembly-2

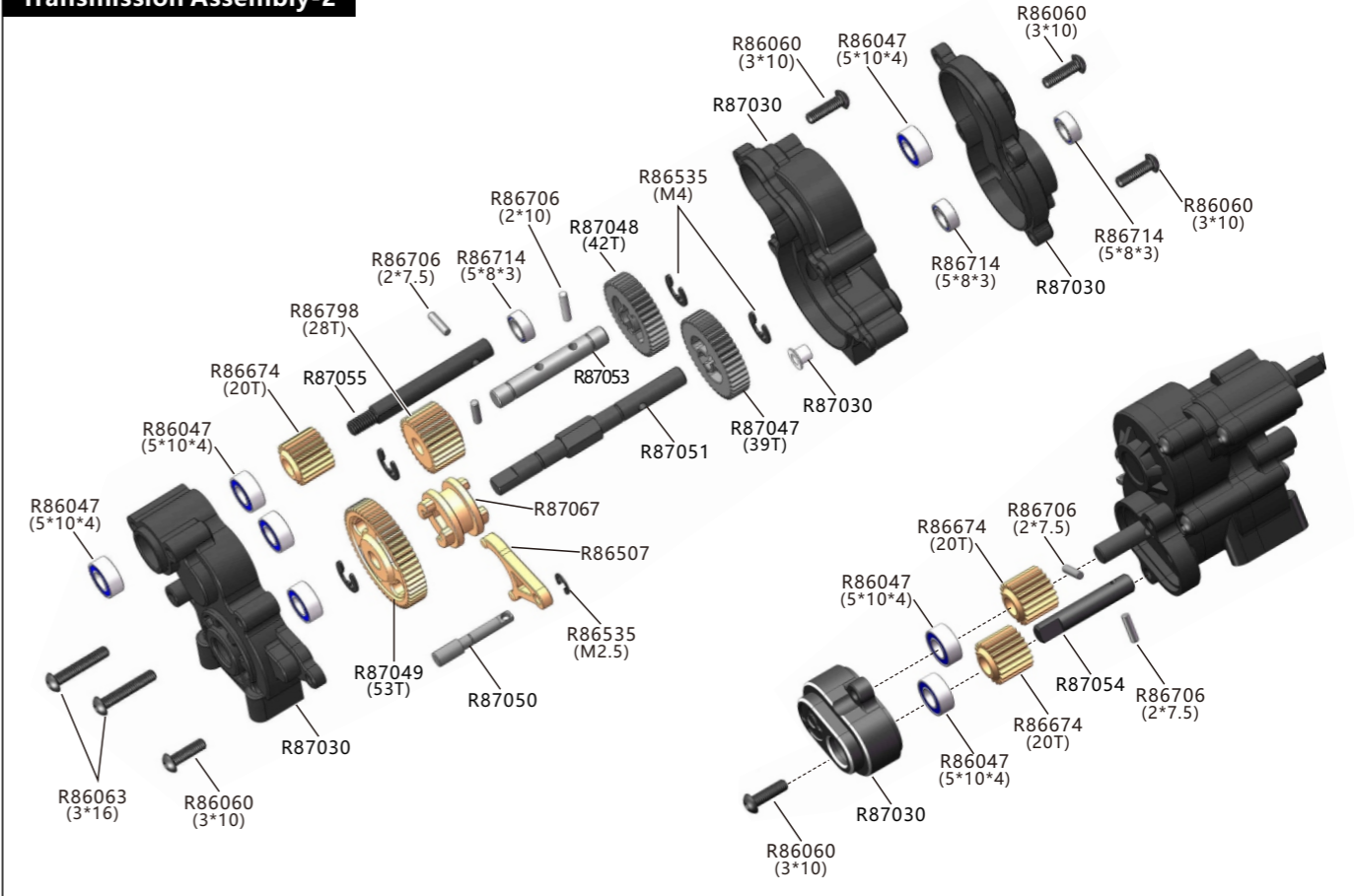

Transmission Assembly-2

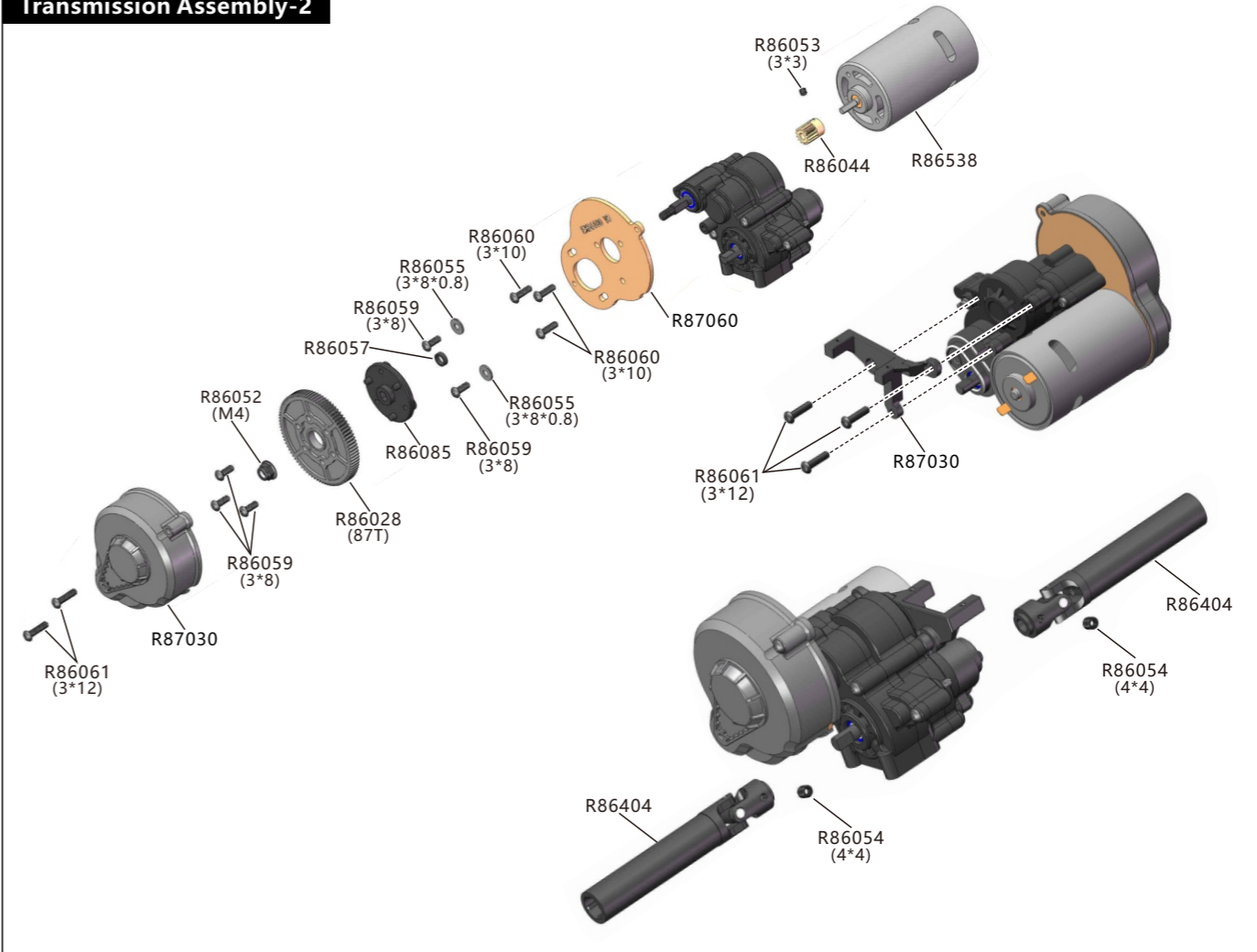

Front Axle Box Assembly

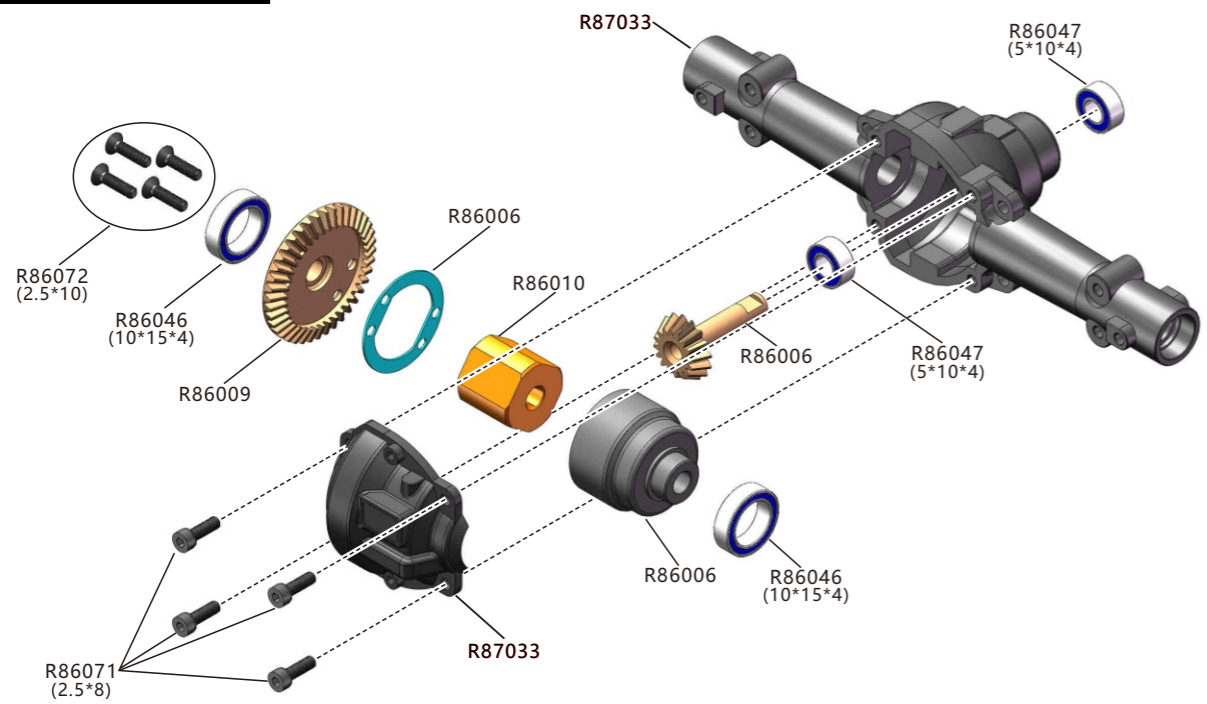

CVD Drive shaft/ Servo Mount Installation

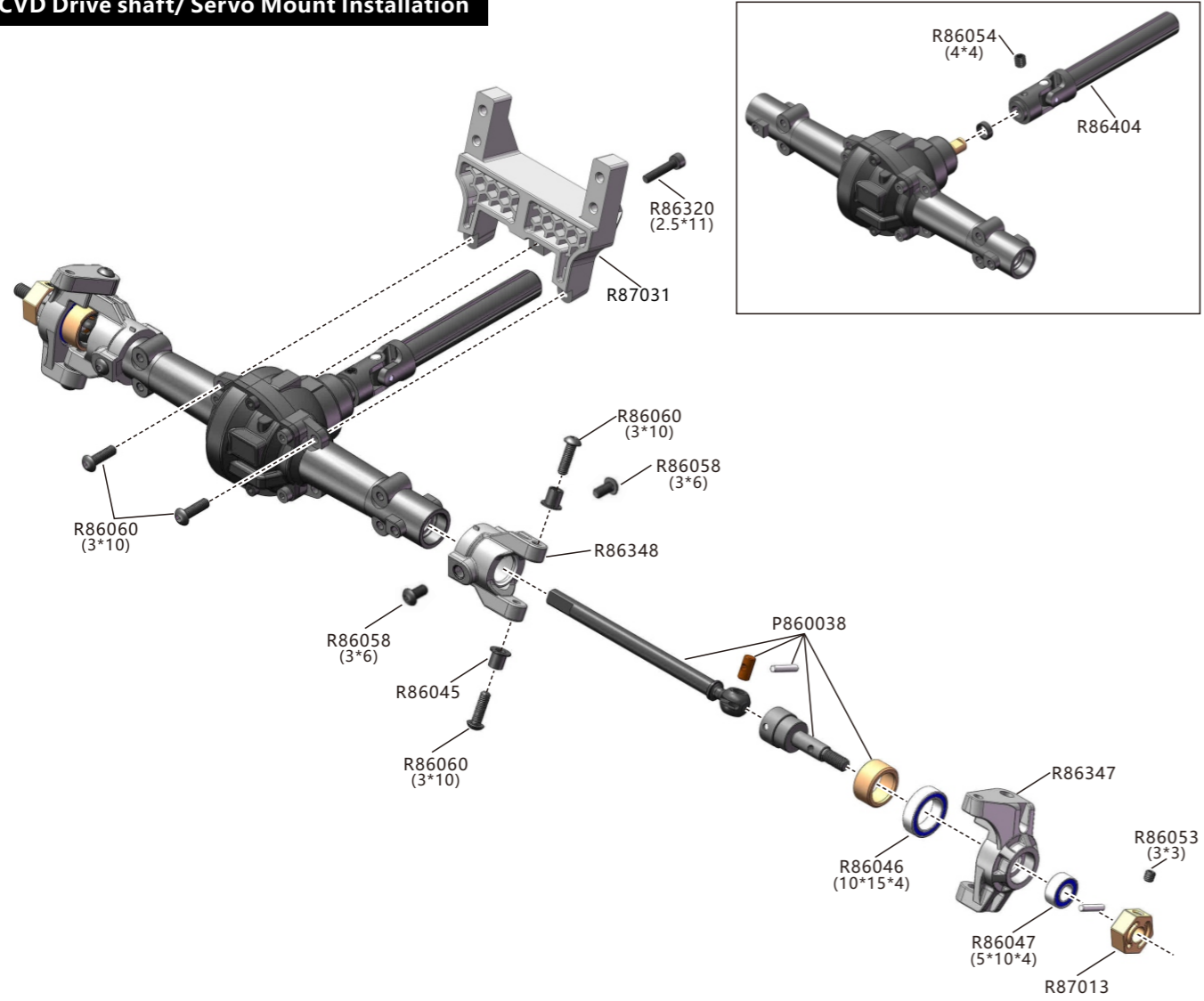

Servo Link /Steering Link Installation

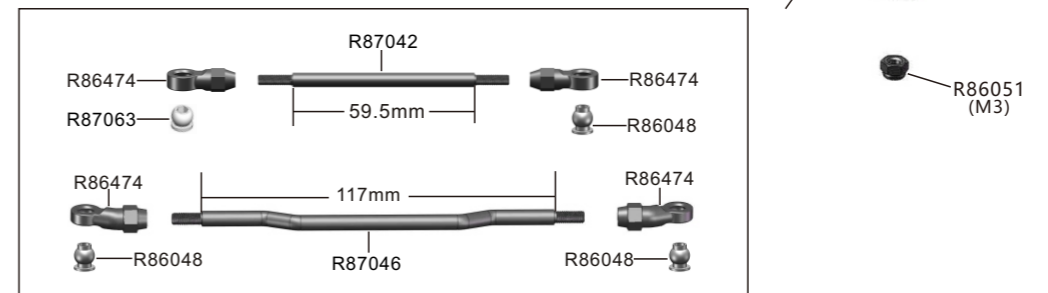
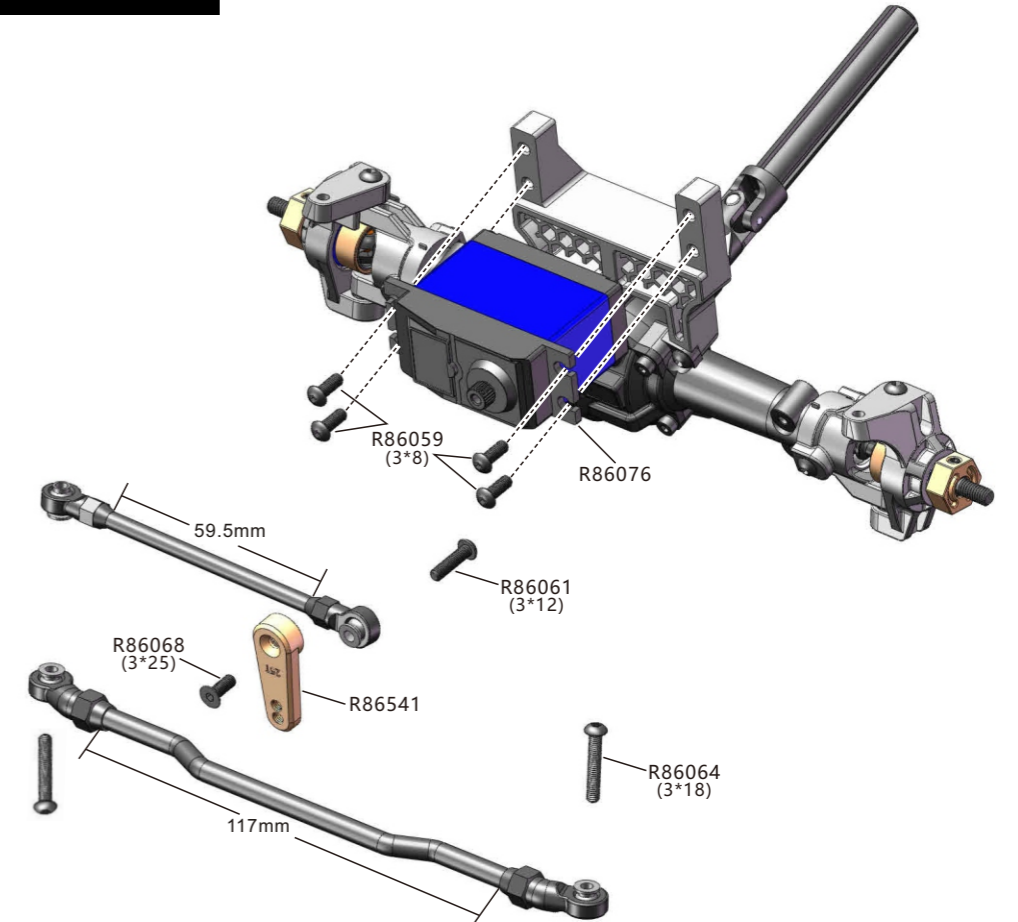

Link Mount Installation

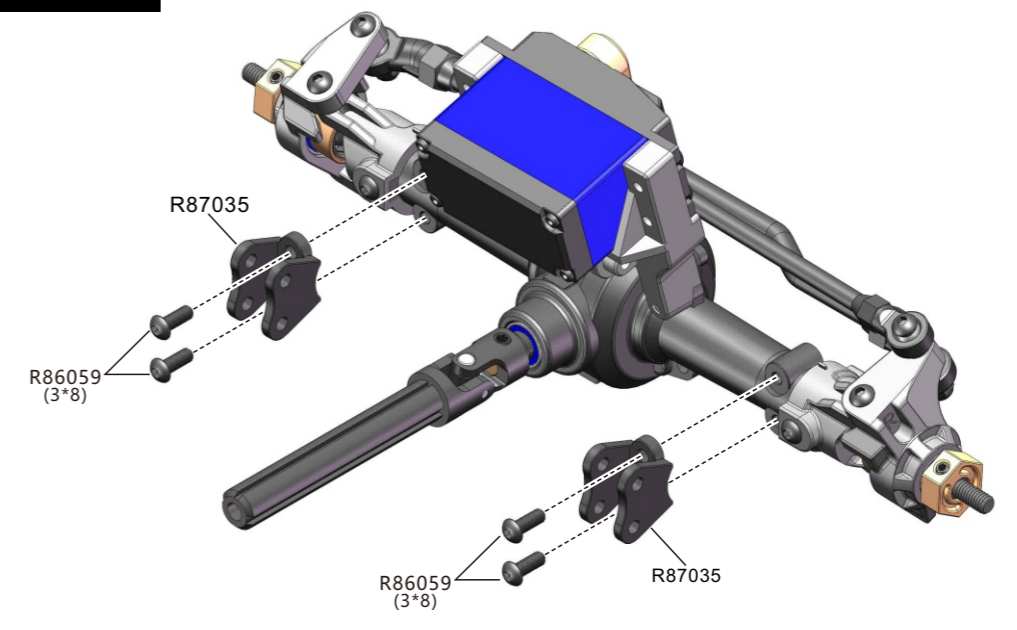

Shock Absorbers Assembly



Front Shock Absorbers/Link Installation

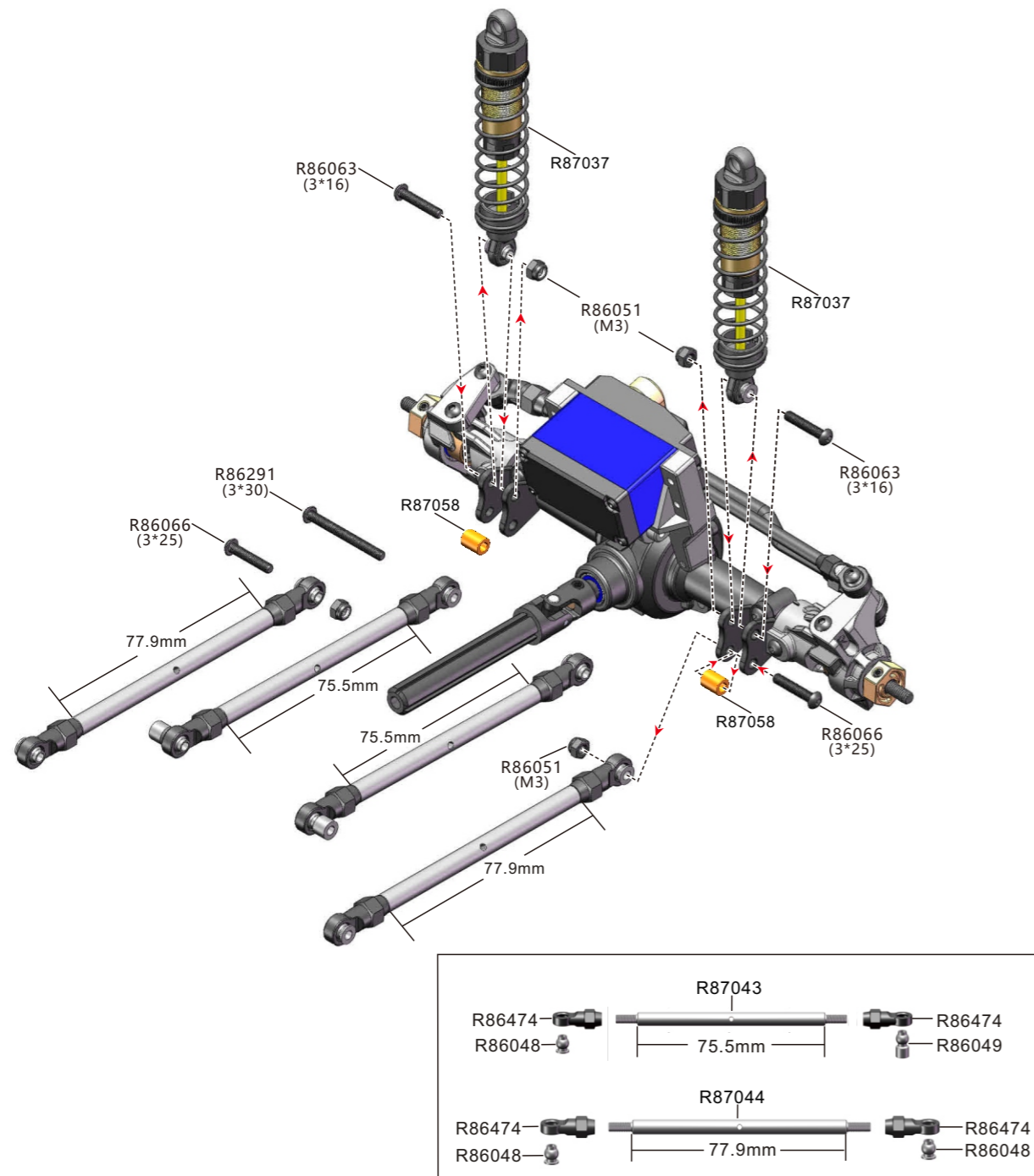

Rear Axle Box Assembly

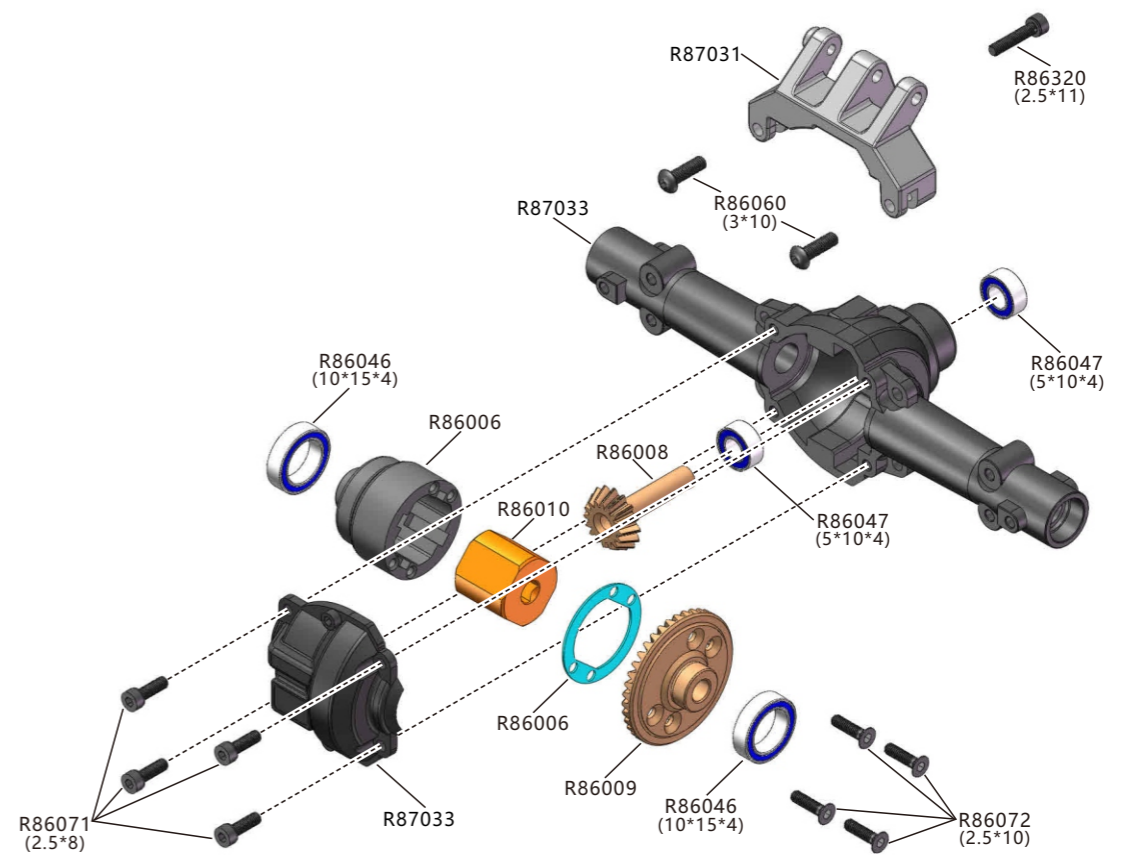

Rear Shaft Assembly

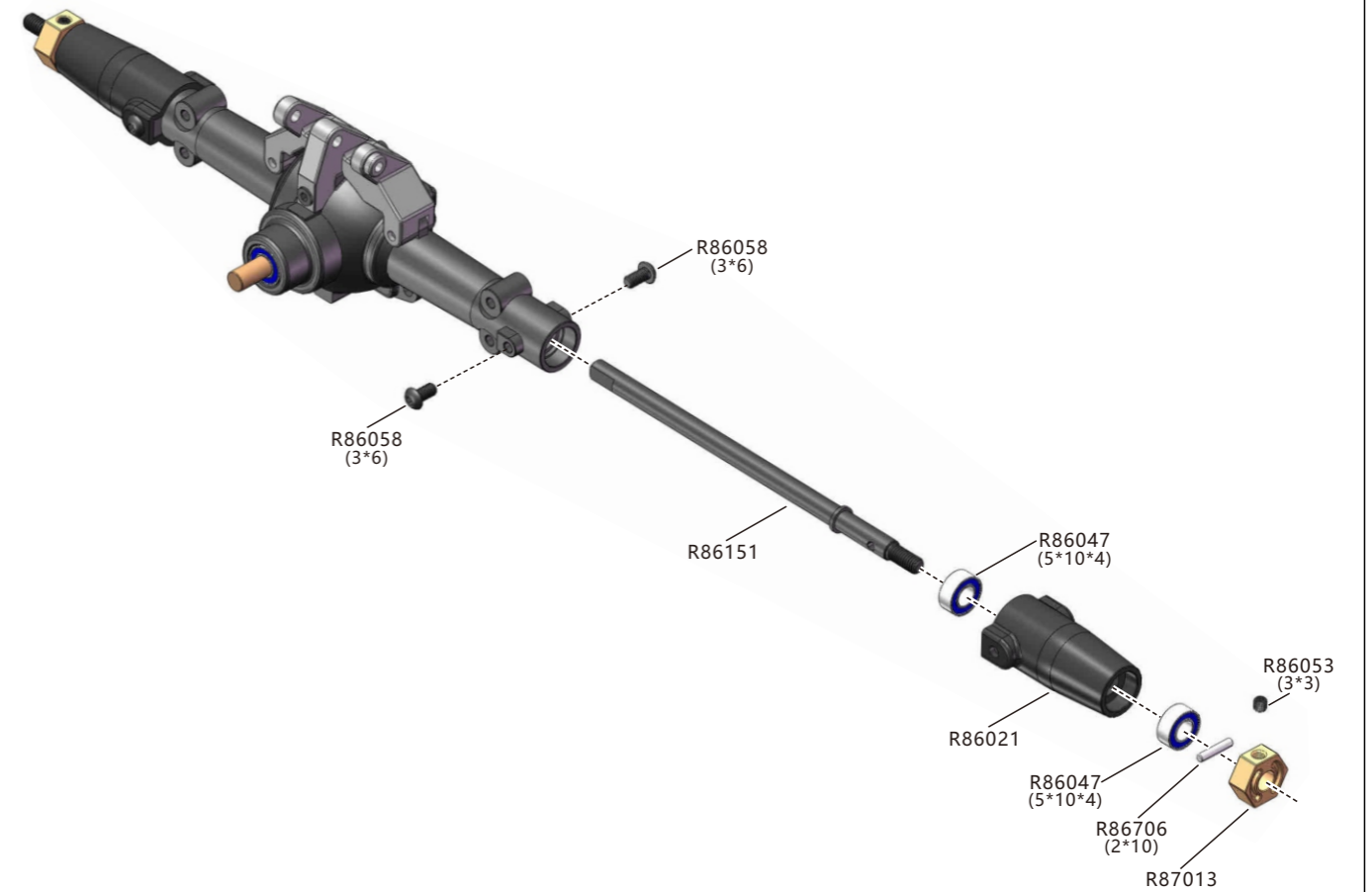

Universal Drive Shaft Assembly

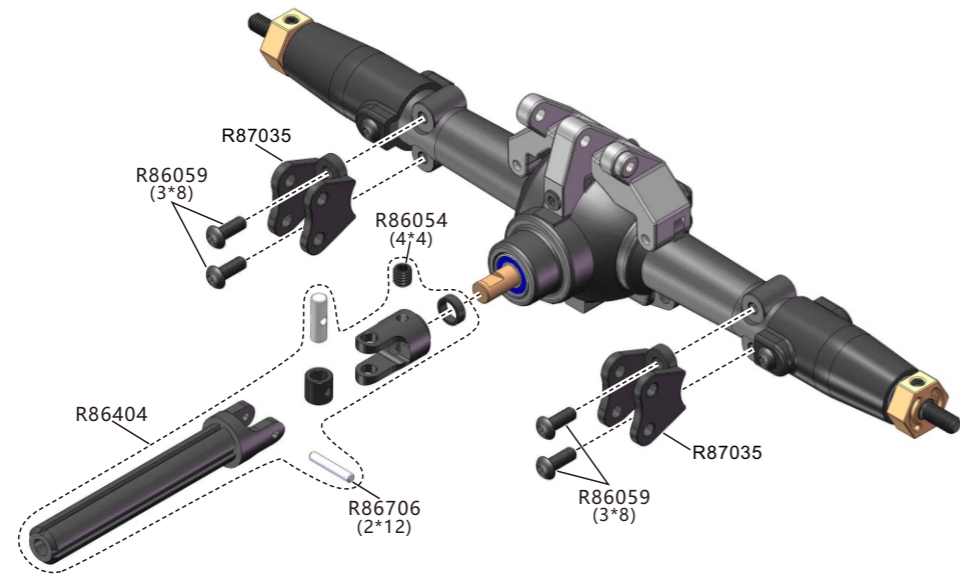

Rear Shock Absorbers/Link Installation

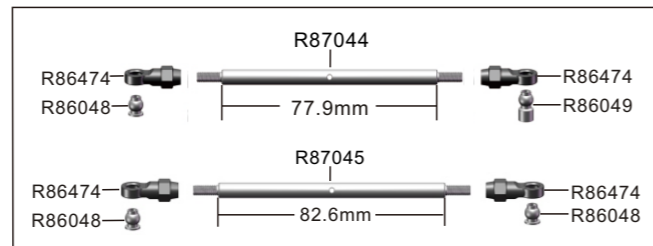
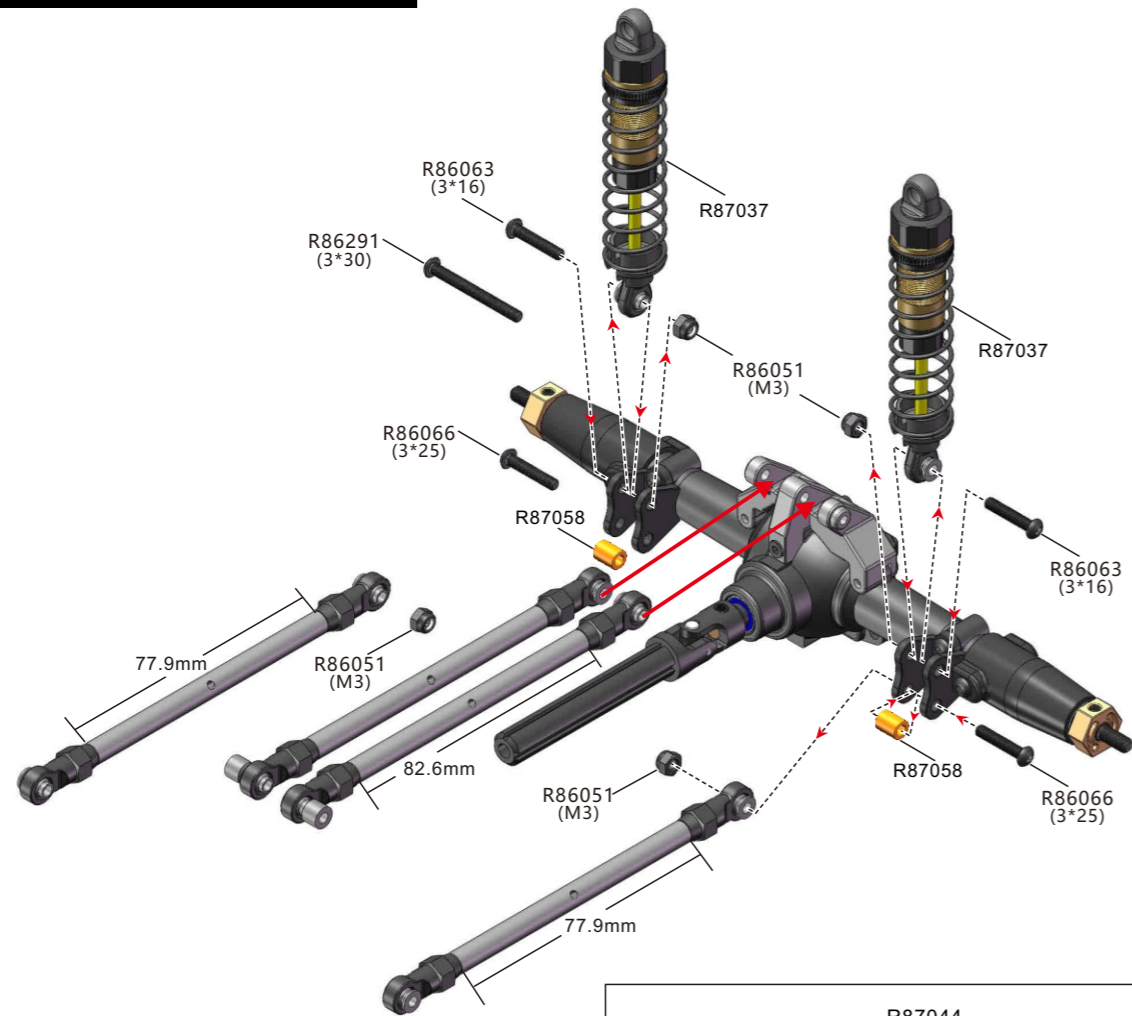

Dust Cover /Chassis Rails Installation

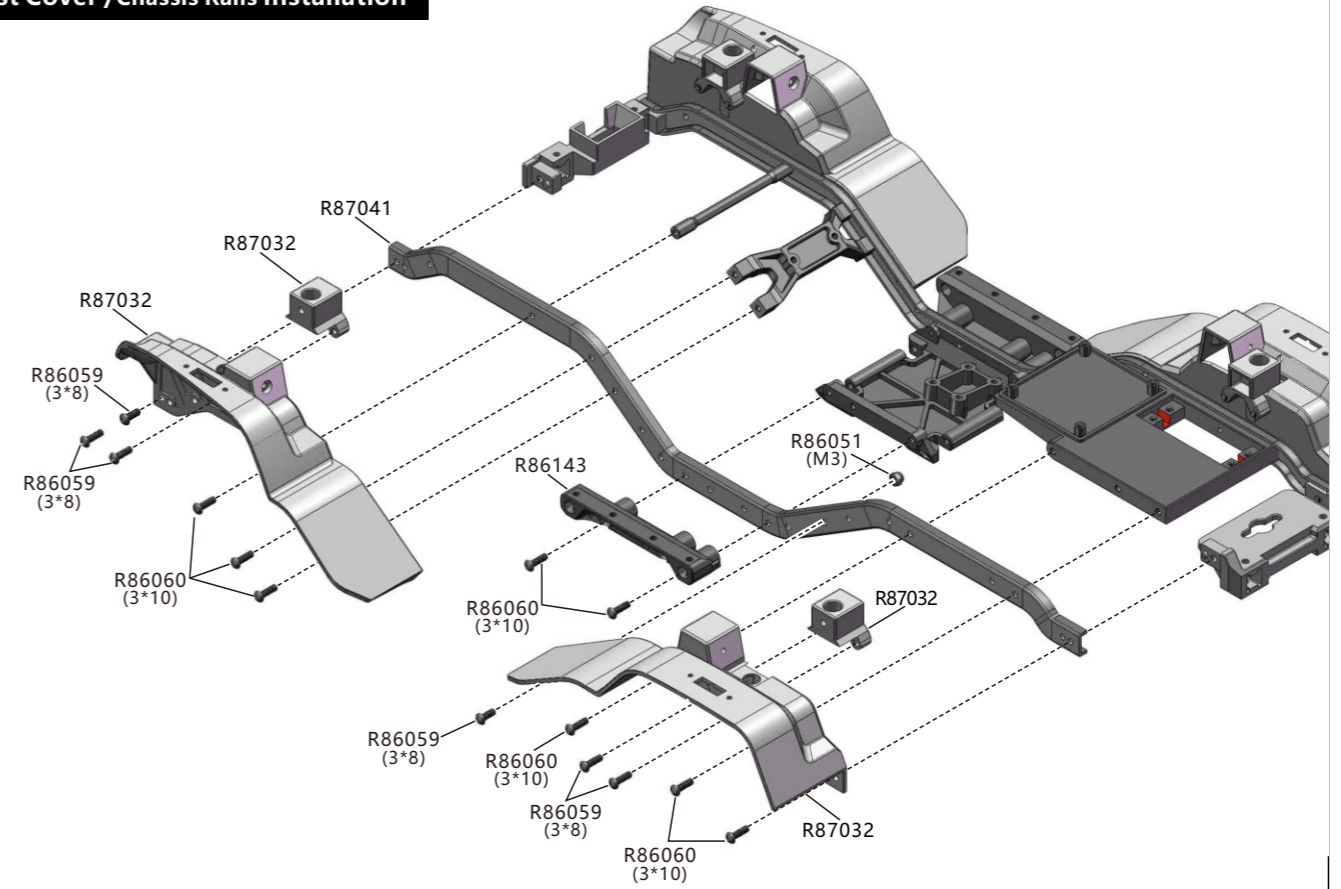

Shock Joint Plate Installation

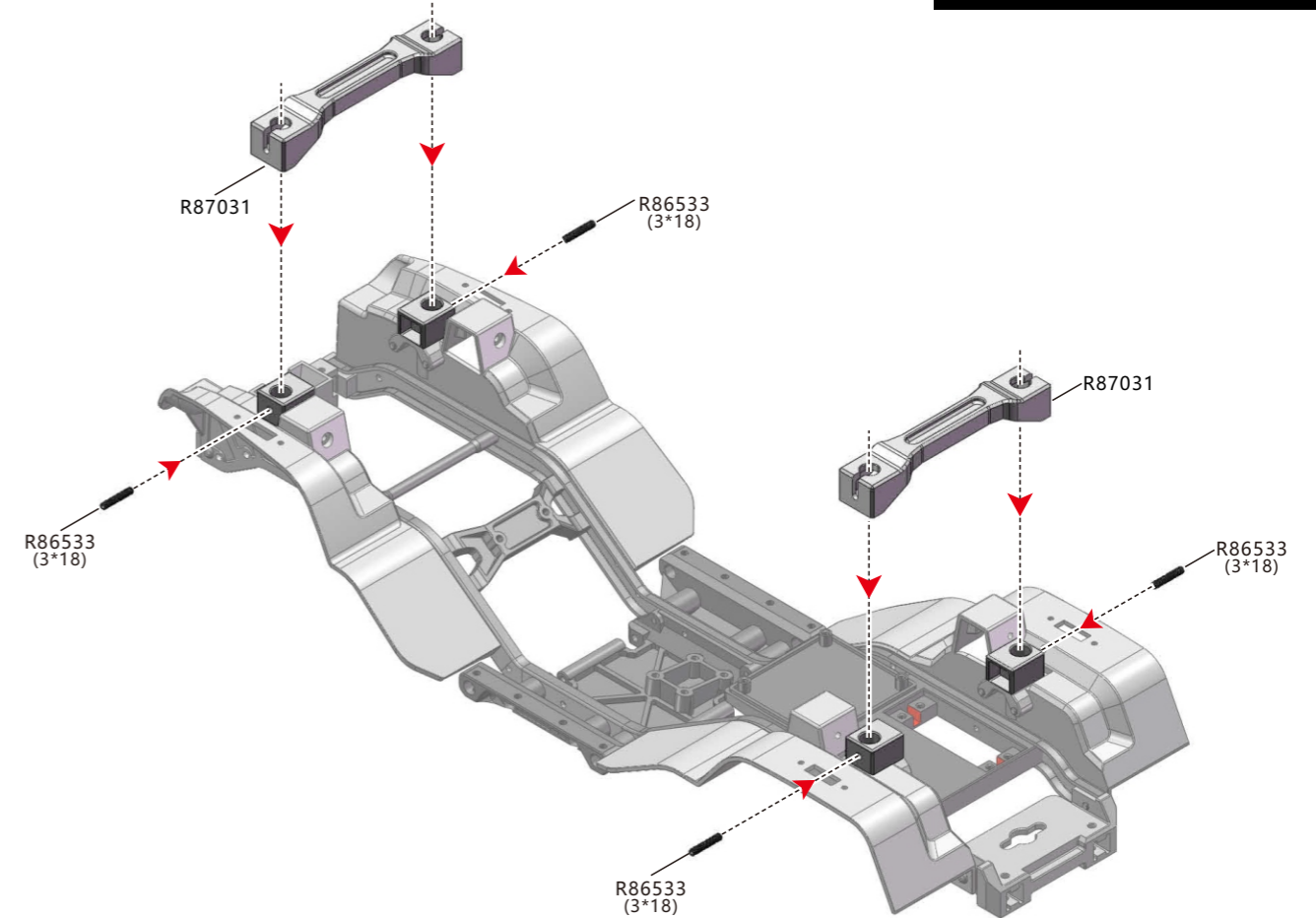

Foot Plate Installation

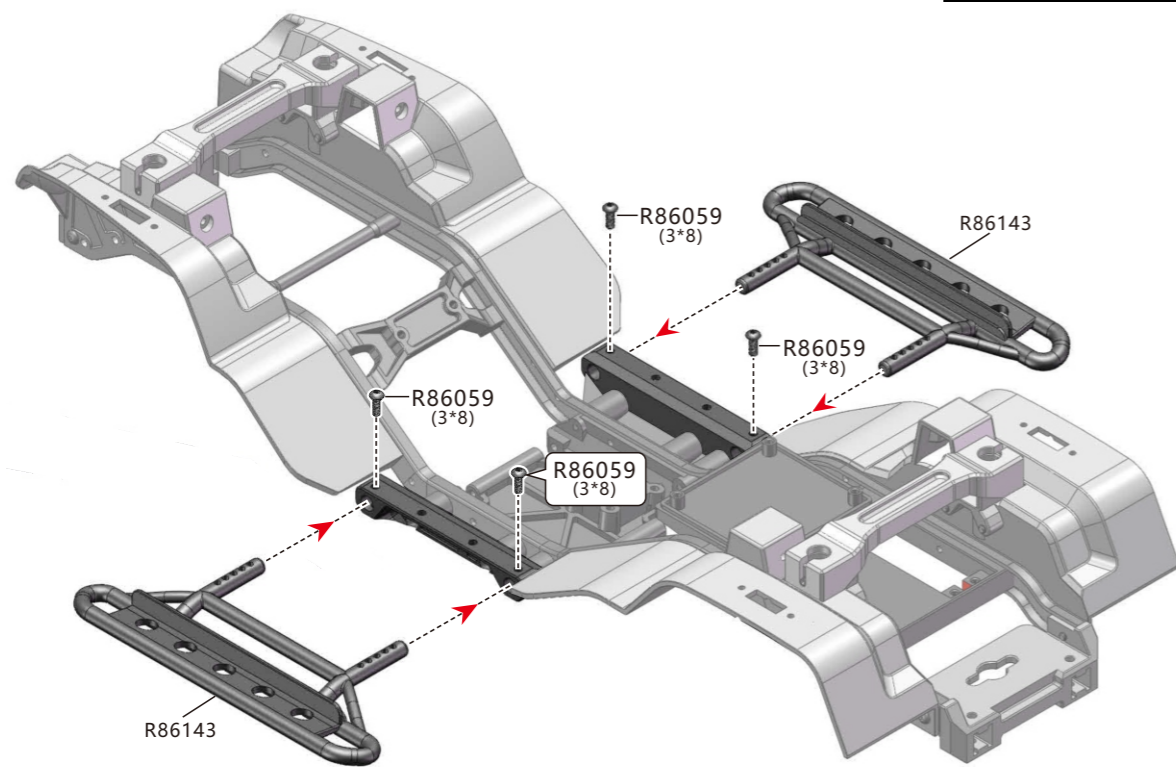

F/R Bumper Installation

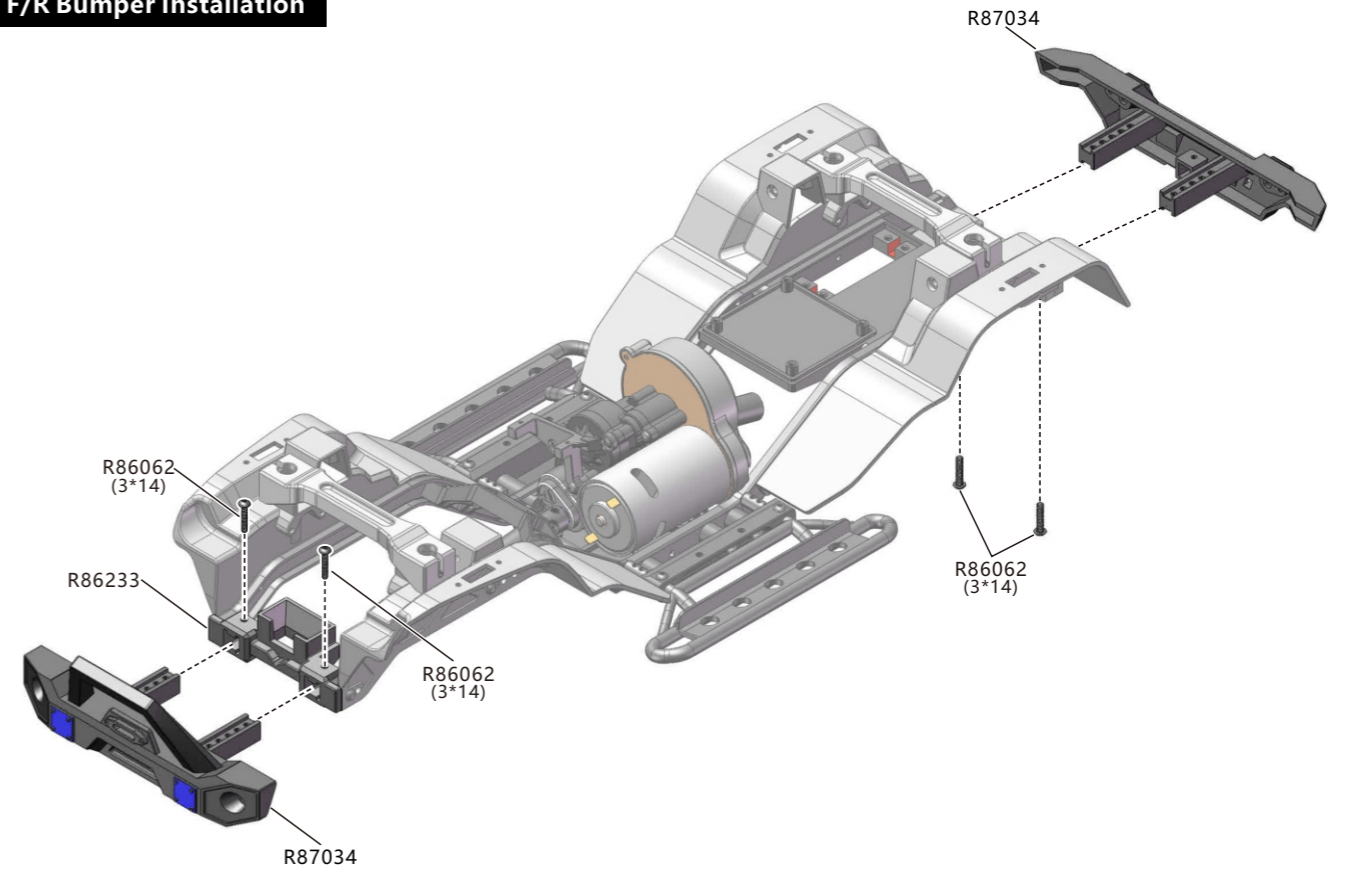

Mounting Center Gear Box Installation

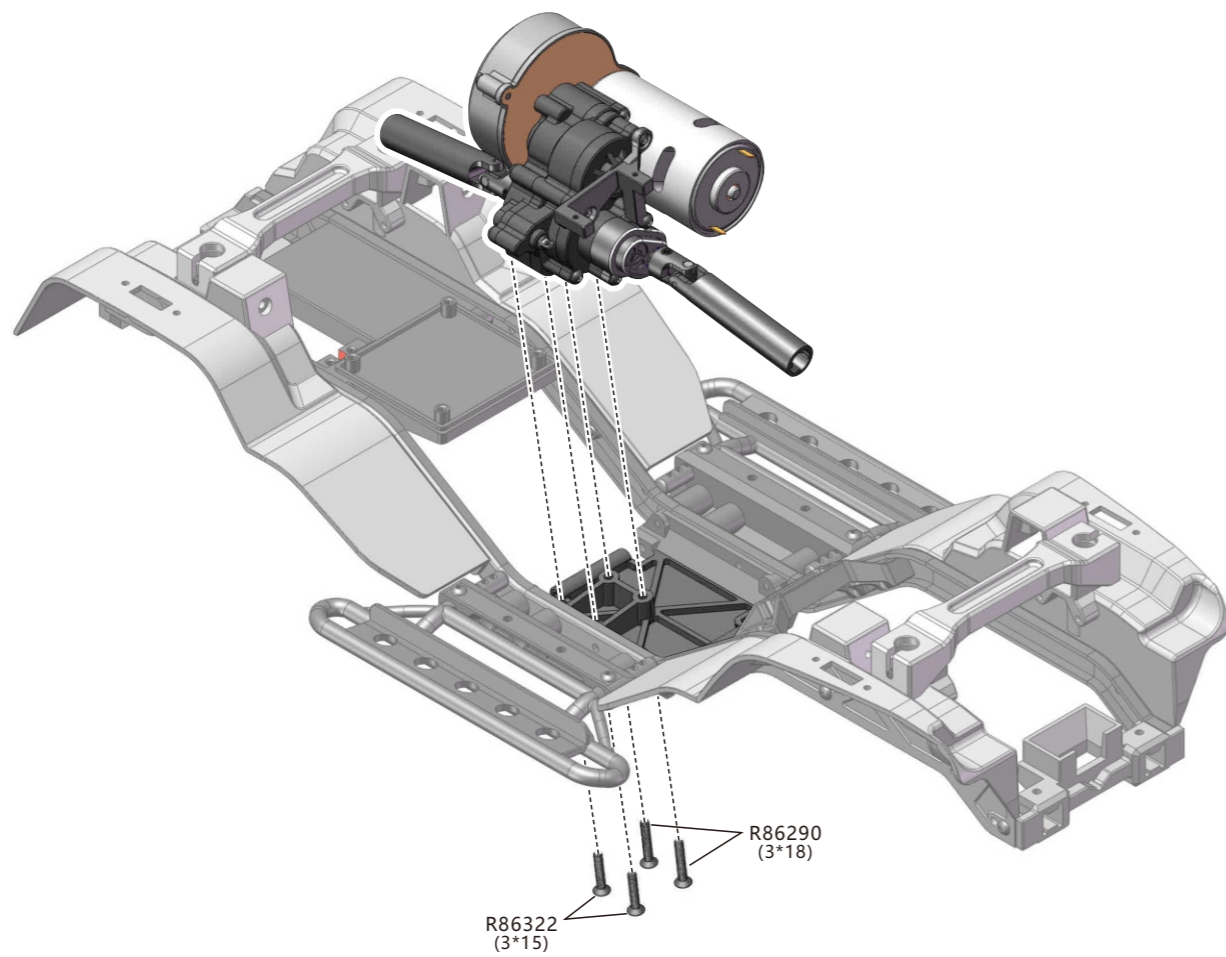

Front Axle Complete Installation

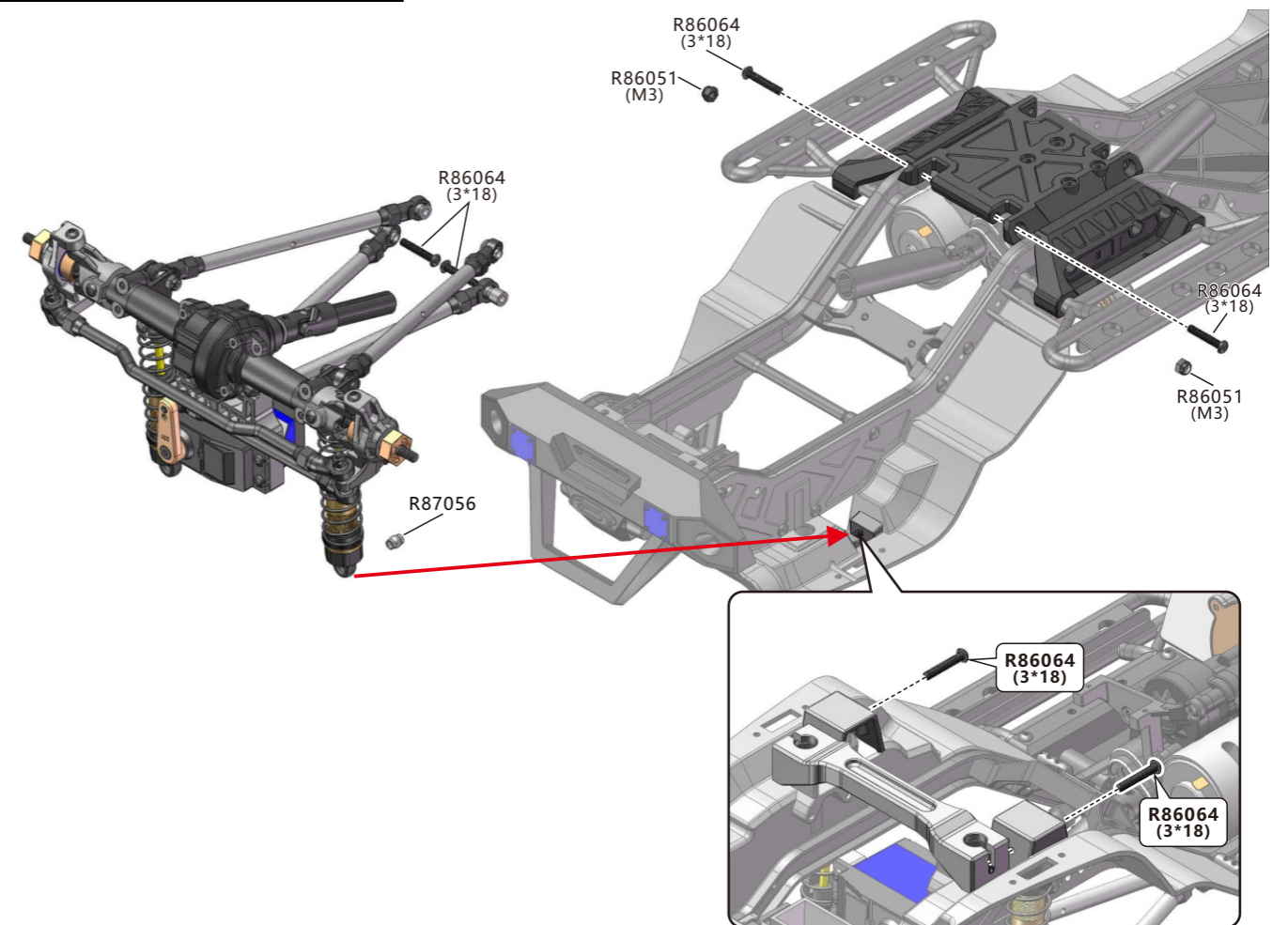

Rear Axle Complete Installation

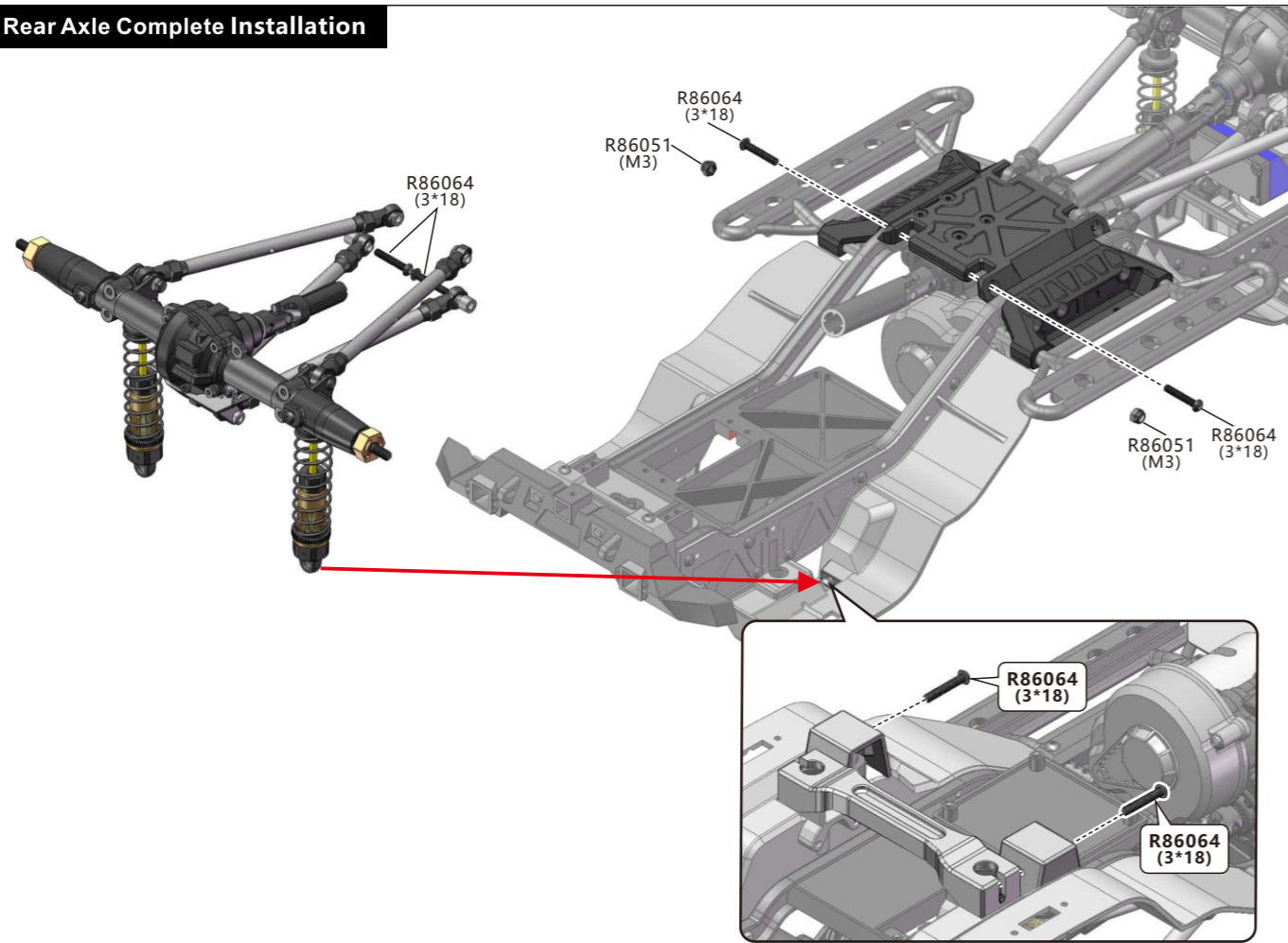

Servo/Dual-speed Link Installation

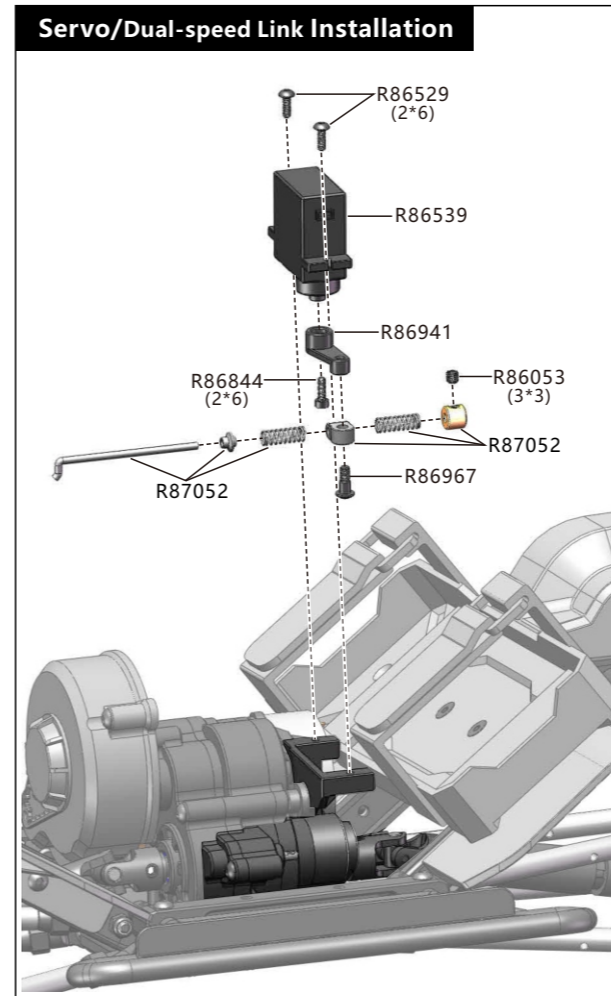

ESC/Receiver Installation

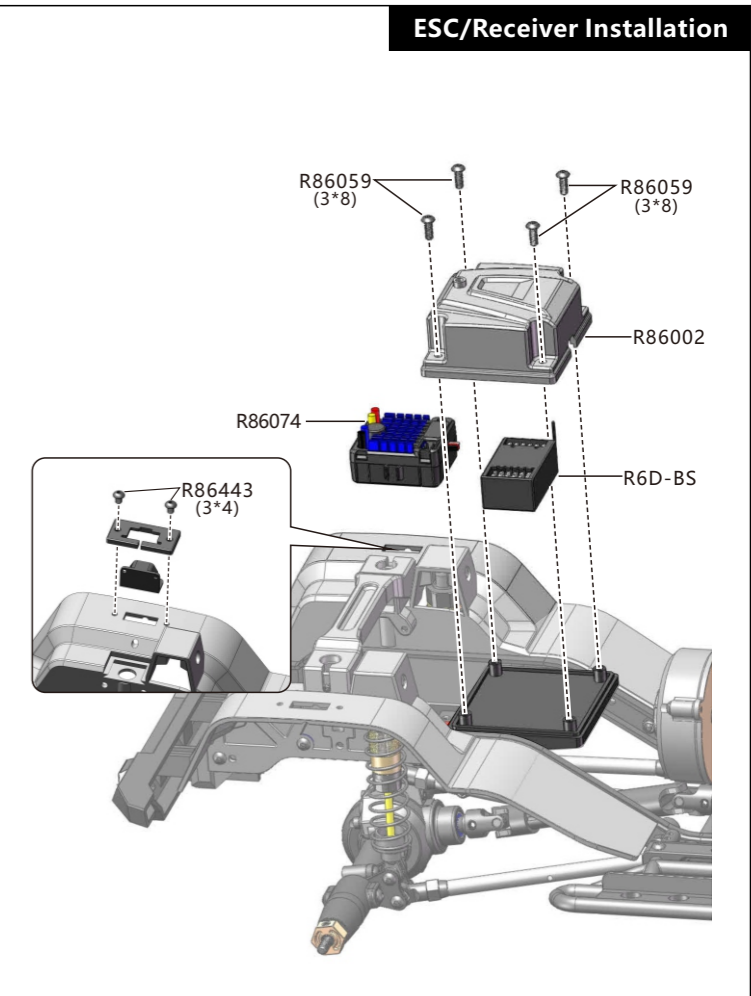

Battery Mount Installation

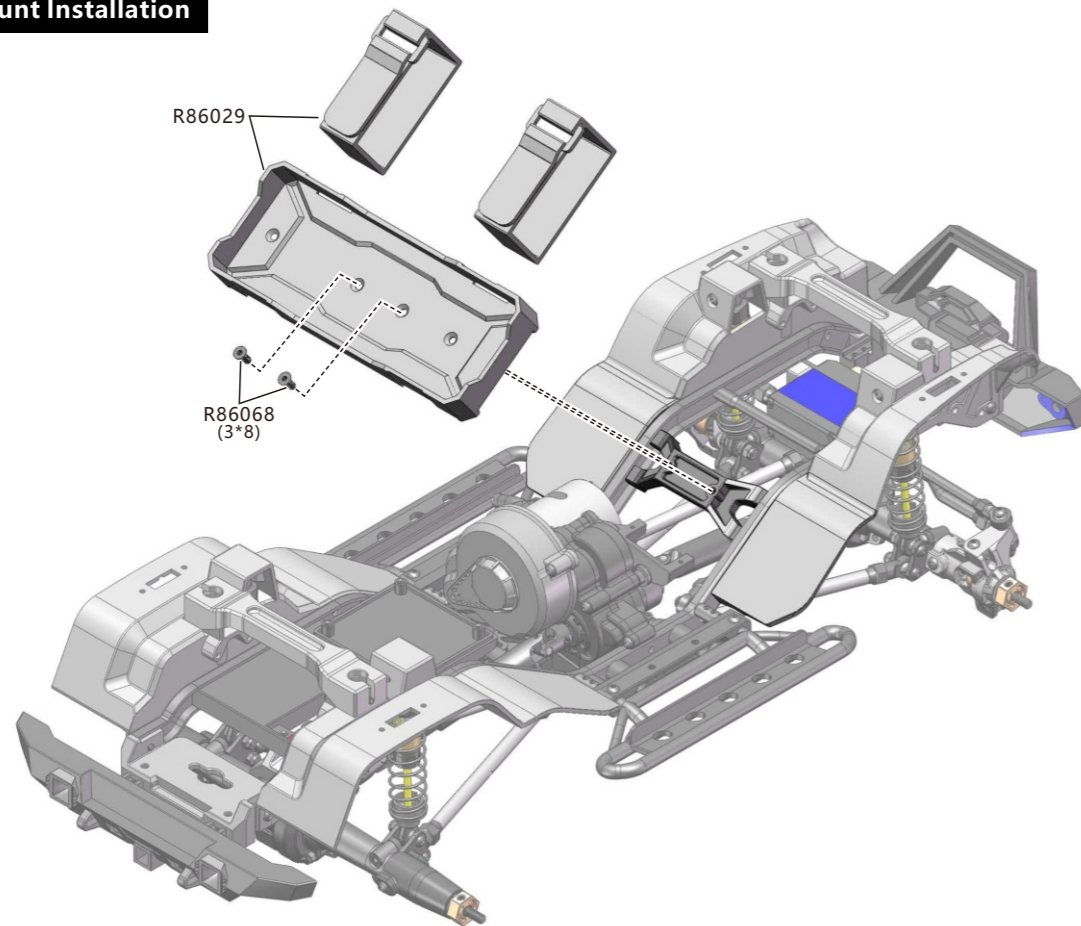

Wheel Installation

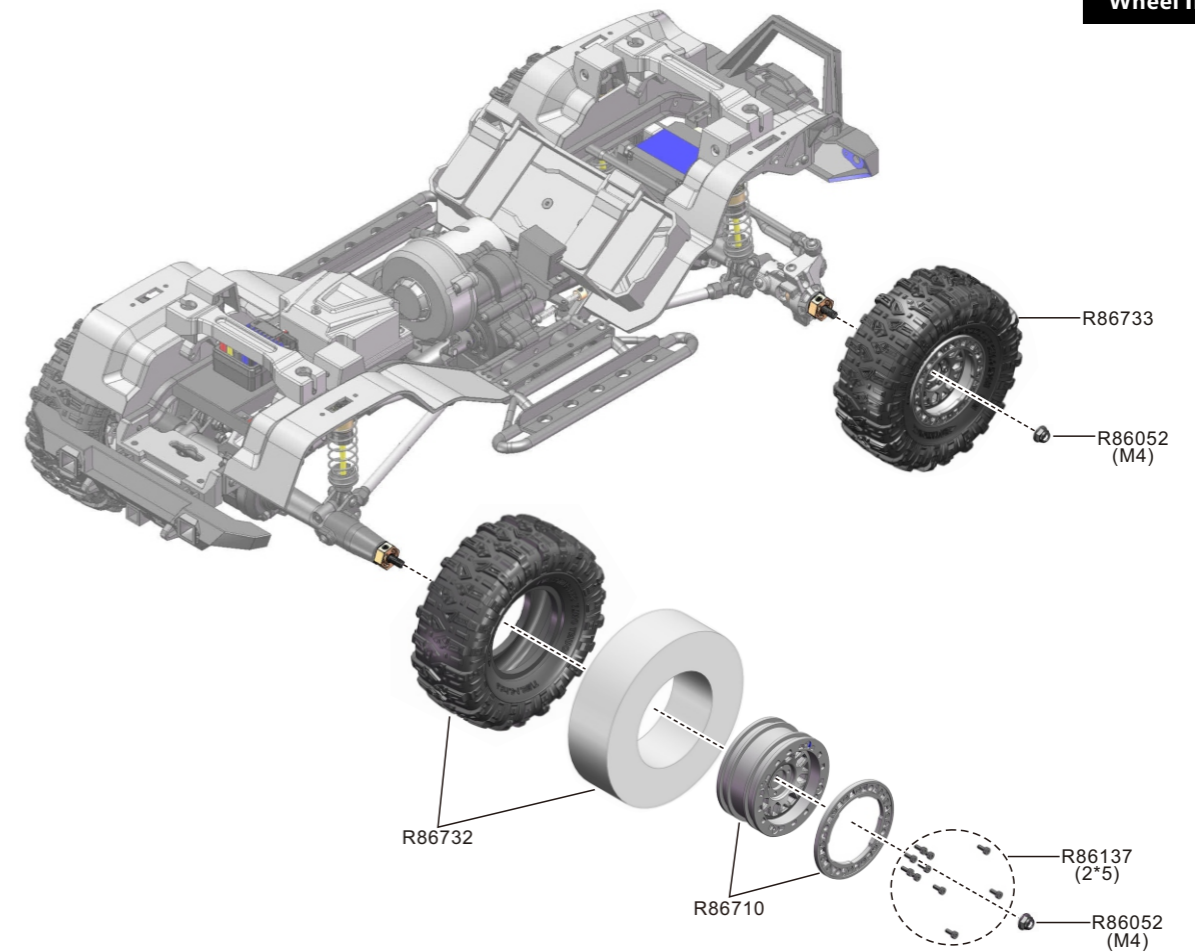

Roof Rack Installation

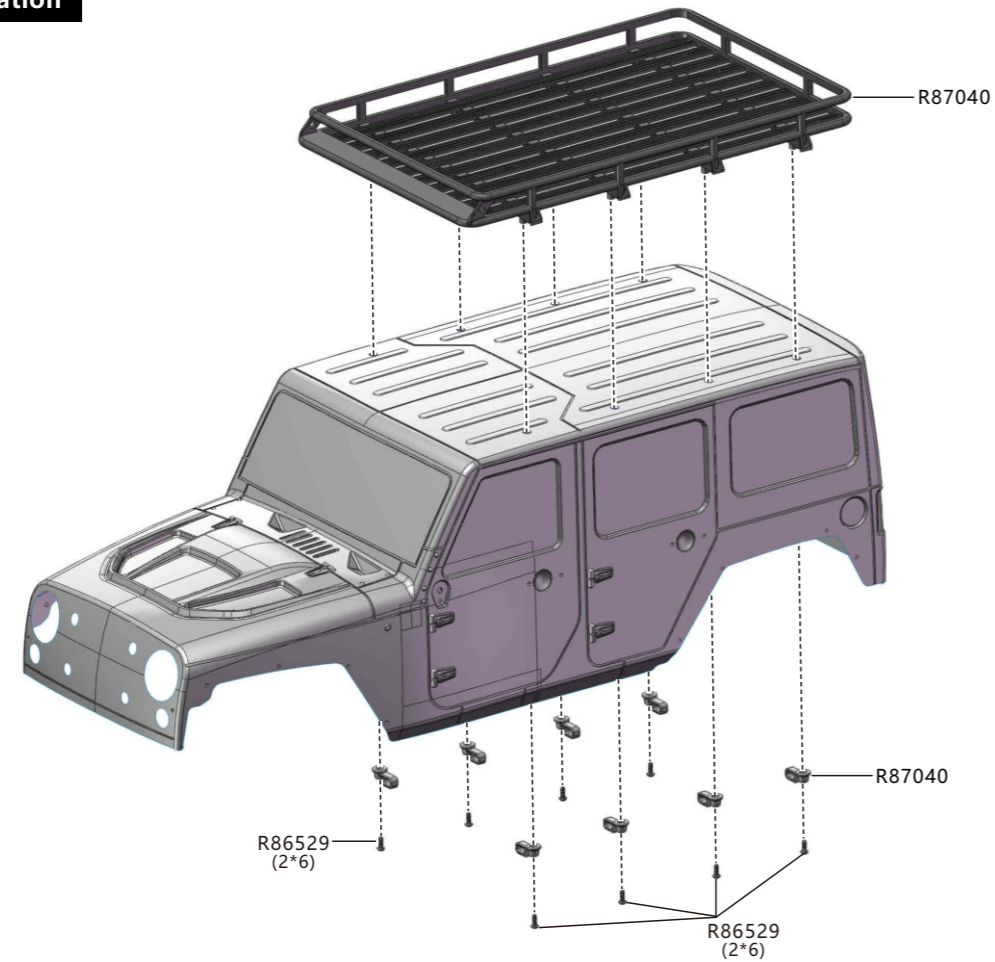

Air Grill Installation

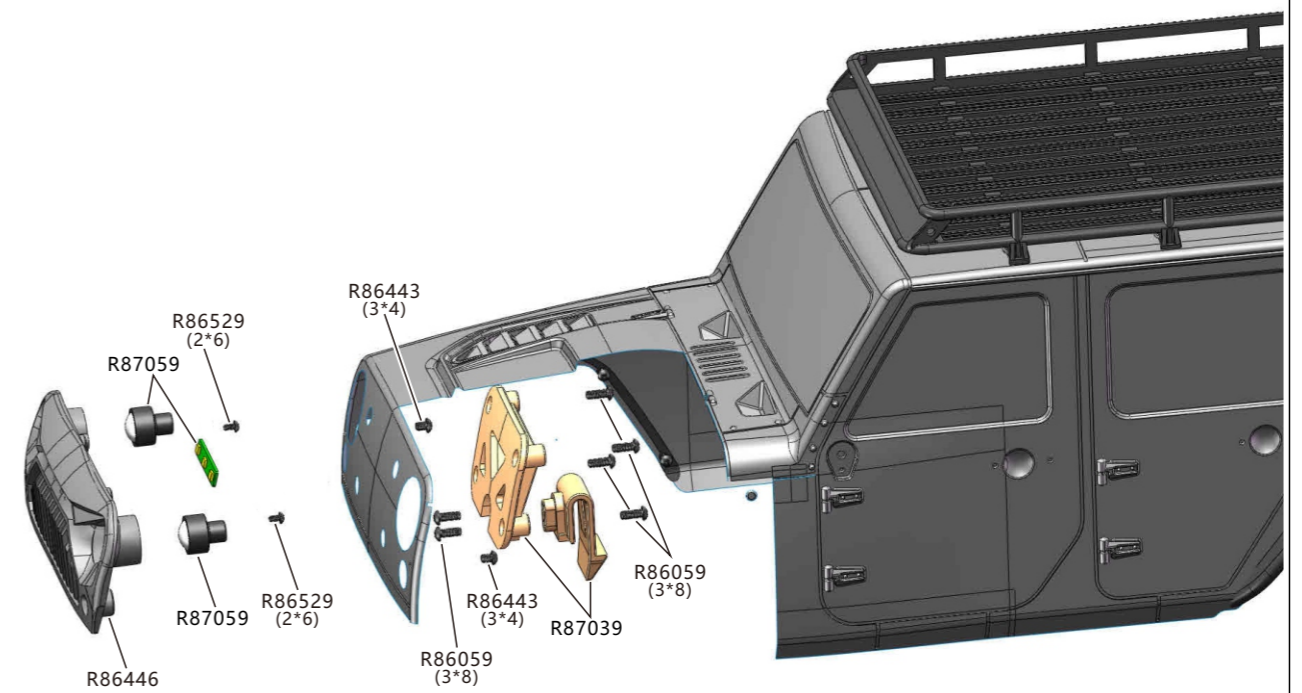

Wheel Eyebrow Installation

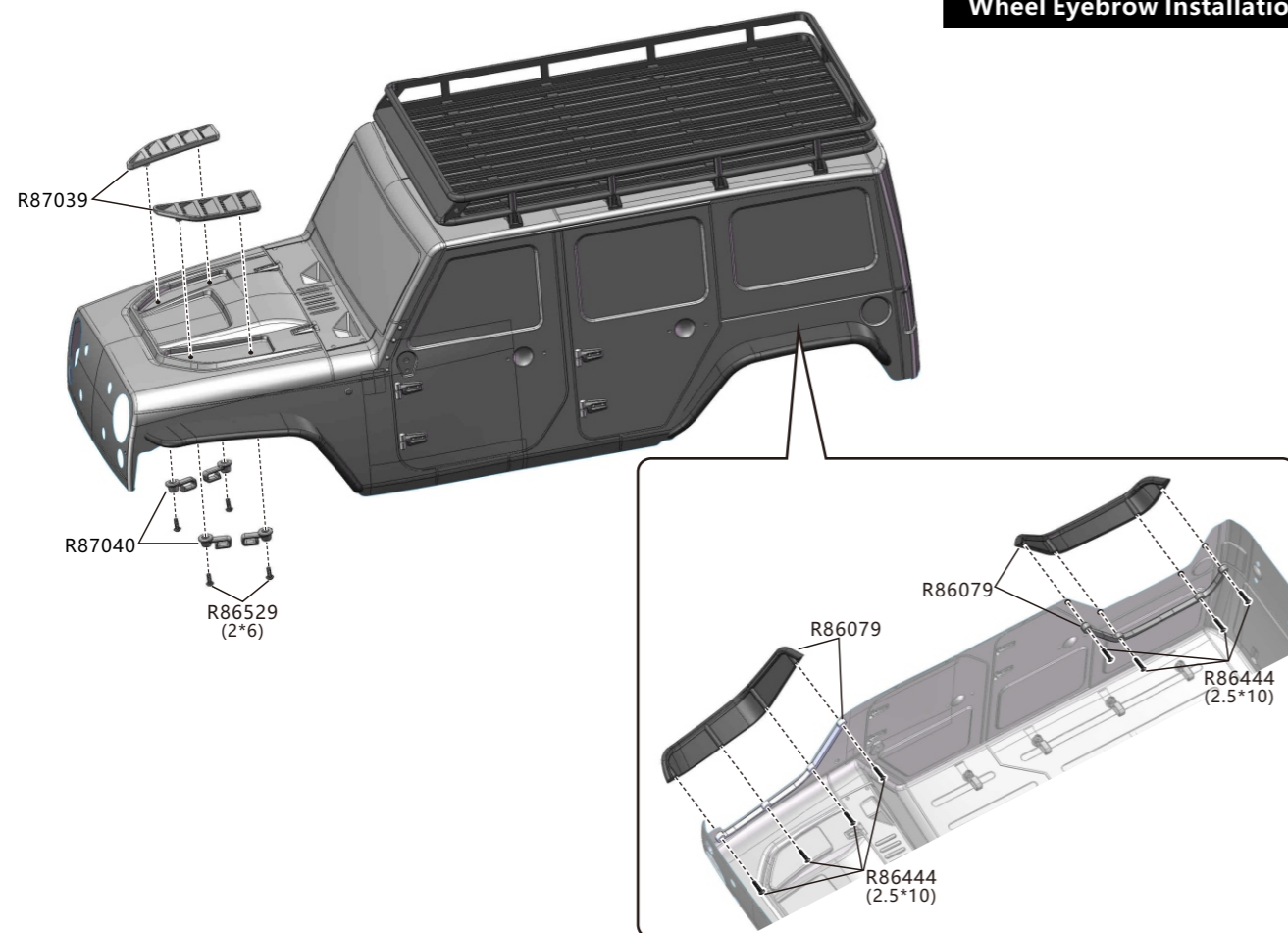

Body Accessories Installation

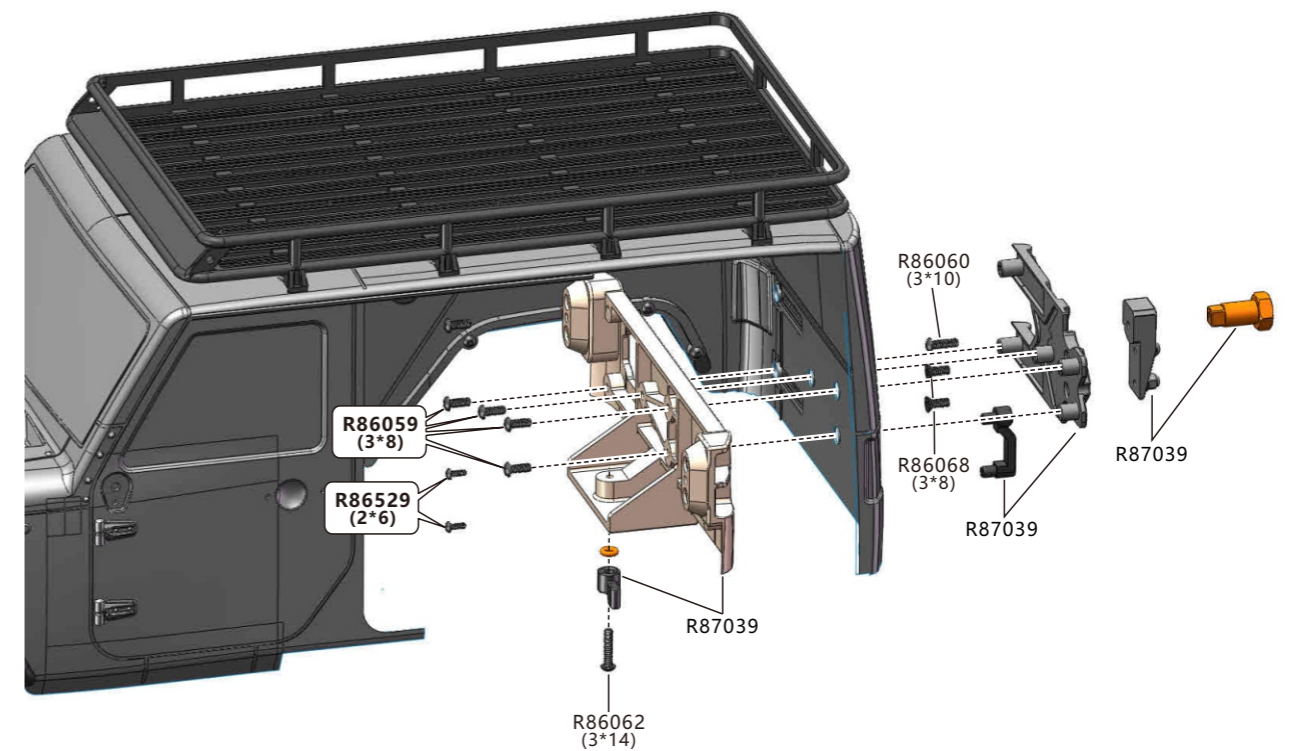

Spare tire Installation

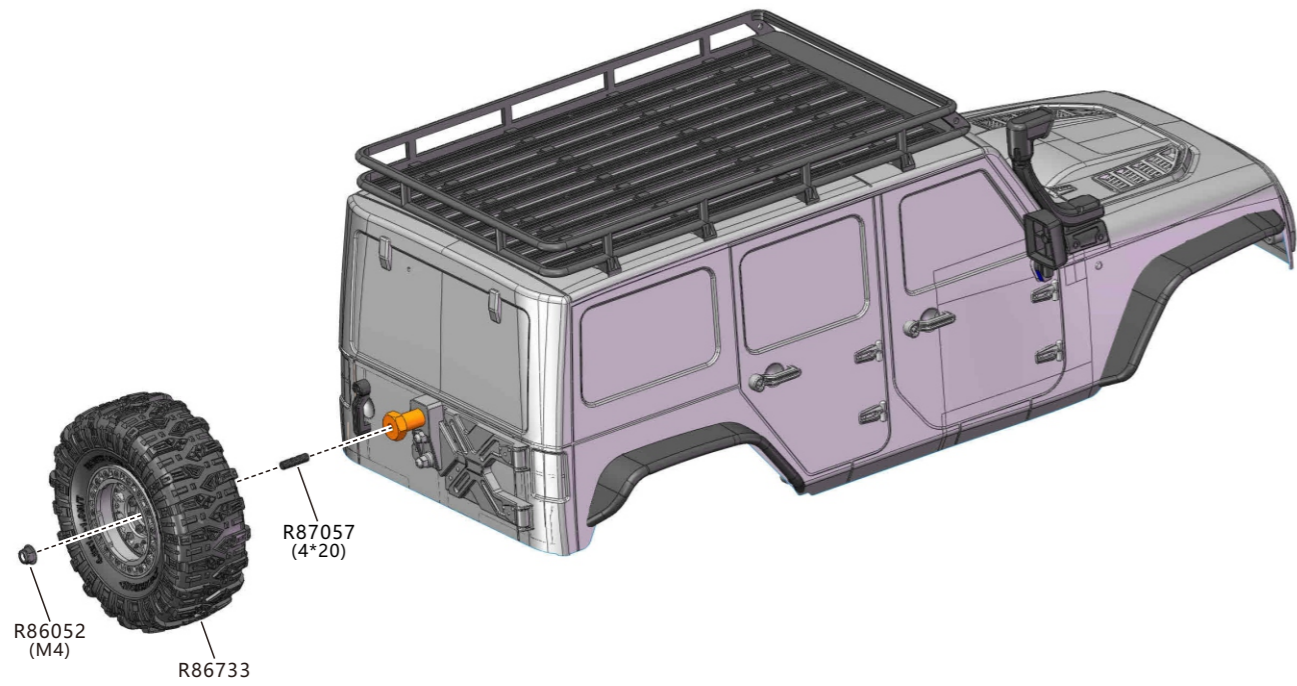

Body Installation

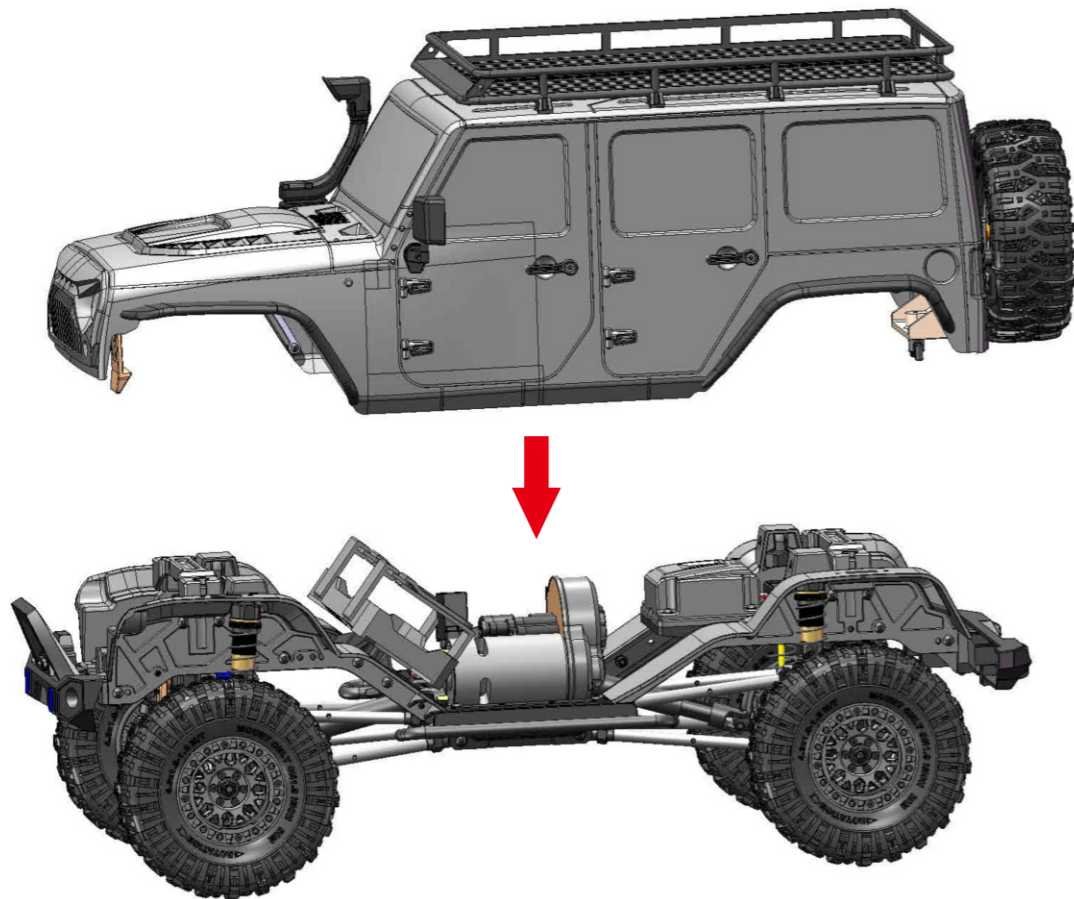









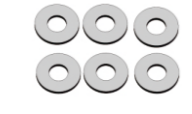

Spare Part

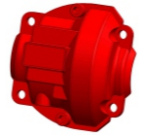
R87030		R87031		R87032					
Dual-speed Gearbox Assembly		Fixing Mount Assembly		Dust Cover Assembly					
R87033		R87034		R86233		R87035		R86002	
Gear Box/Housing		F/R Bumper		Bumper Mount		Link Mount		Servo/ Receiver Mount	
R86029		R86143		R86348		R86347		R86006	
Battery Mount		Foot Plate Set M3*10 4PCS M3*12 4PCS M3*20 2PCS		Steering Hubs(L/R)		Steering Hub Carriers(L/R)		Differential Box	
R87036		R86474		R86708		R87037			
Switch Mounting Cover		Link Ends		Shock Repair Kit (completed car) 2.8*1.9mm 8*1mm		Shock Absorbers			
R86710		R86732		R86733					
Wheel Rim (Matte Silver)		Tire W/Foam (Ø110mm)		Wheel Complete L/R (Ø110mm)					
PC body+Sticker		Pre-Assembled PC Body		R87039					
R87038-0(Clear) R87038-1(Grey) R87038-2(Orange) R87038-3(Red)		P86492-1(Grey) P86492-2(Orange) P86492-3(Red)							
Body Accessories		Body Accessories		Body Accessories					
R86079		R86080		R86446		R87040			
Wheel Eyebrow 2.5*10 16PCS		Body Shell Parts 3*4 4PCS		Air Grill (New) 3*4*2Pcs 3*4*2Pcs		Roof Rack			

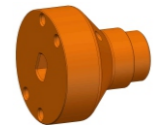
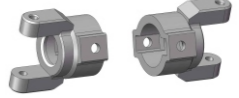
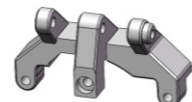
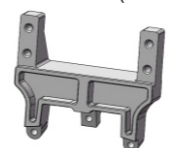
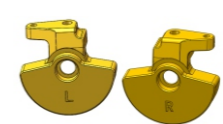
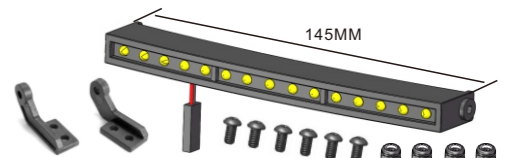
Spare Part				
R87041 Chassis Rails(L/R)	R87042 Servo link 59.5mm	R87043 Link 75.5mm	R87044 Link 77.9mm	
R87045 Link 82.6mm	R87046 Steering Link 117mm	R86008 Drive Gear 16T	R86009 Crown Gear(40T)	R86010 Solid Axle Hub
R86674 Gear(20T)	R86798 Gear(28T)	R87047 Gear(39T)	R87048 Gear(42T)	R87049 Gear(53T)
R86028 Main Gear set(87T)	R86085 Gear Mount	R86404 Universal Drive Shaft	P860038 CVD Drive Shaft	R86833 Joint Link
R87067 Transmission Slider	R86507 Gear Stick	R87050 Speed Shift Block Shaft	R87051 Dual-speed Gear Shaft	R87052 Dual-speed Link
R86151 Rear Shaft	R86021 Rear Straight Axle	R87053 Gear Shaft 33.2mm	R87054 20T Gear Shaft	R87055 Primary Gear Shaft
R87013 Wheel Hex.(Steel)	R86045 King Pin Bushing	R86047 Ball Bearing Ø5*Ø10*4	R86714 Ball Bearing Ø5*Ø8*3	R86046 Ball Bearing Ø10*Ø15*4

Spare Part				
R86048 Ball Stand 5.9mm(Short)	R86049 Ball Stand 5.9mm(Long)	R87056 Shock Balls 5.0	R87063 Shock Balls 5.8	R86051 Nylon Nut M3
R86052 Flange M4 Lock Nut	R86529 Button Head Self-tapping 2*6mm	R86444 Button Head 2.5*10mm	R86443 Button Head 3*4mm	R86058 Button Head 3*6mm
R86059 Button Head 3*8mm	R86060 Button Head 3*10mm	R86061 Button Head 3*12mm	R86062 Button Head 3*14mm	R86063 Button Head 3*16mm
R86064 Button Head 3*18mm	R86066 Button Head 3*25mm	R86291 Button Head 3*30mm	R86072 Flat Head 2.5*10mm	R86068 Flat Head 3*8mm
R86322 Flat Head 3*15mm	R86290 Flat Head 3*18mm	R86137 Cap Head Self-tapping 2*5mm	R86844 Cap Head 2*6mm	R86071 Cap Head 2.5*8mm
R86320 Cap Head 2.5*11mm	R86053 Crub Screw Bolt 3*3mm	R86054 Crub Screw Bolt 4*4mm	R86533 Crub Screw Bolt 3*18mm	R87057 Crub Screw Bolt 4*20mm
R86321 Flange Head Screws 3*4mm	R86967 Cross Head Hex Screw 2.5*7mm	R86535 E-Clips(Ø2.5mm/Ø4mm)	R86594 E-Clips(Ø2.3mm/Ø4mm)	R86706 Pin 2*7.5mm/2*10mm/2*12mm

Spare Part				
R86536  Pin - 2*10mm/2*11mm/2*12mm	R86537  Metal Washer(Ø2.6*Ø6*0.5)	R86055  Metal Washer(Ø3*Ø8*0.8)	R86057  Gasket(5.2*6.5*2)	R87058  Lower Link Spacer Post
R86024  Light Clip	R87059  Light Set	R86941  Servo Horn	R86541  Servo Horn(25T)	R86076  Servo 15KG
R86539  Dig Servo 9G /7.4V	R86074  ESC(40A)	R86044  Motor Gear(14T)	R87060  Dual-speed Motor Mount(AL) (Blue)	R86538  Motor-550/8020
DB01  Light Controller Box	R87061  Radio/Receiver	MG6-BS  Radio	R6D-BS  Receiver	R87062  Transmission Set

Upgradable Optionals				
P860002  Portal Axle Box Cover(AL)	P860005  Mount for Link(AL)	P860008  Mount for Link(AL)	P860018  Straight Axle Mount(AL)	P860075  Caster Mounts(L/R)(AL)
P860145  Rear Link Mount(AL)	P860146  Servo Mount (COPPER)	P860147  Steering Hub Carriers(L/R) Housing Weight Set 134g (COPPER)	P860077  Adjustable LED Lamp 145MM	
R86788  Tire W/Foam	R87064  Wheel Rim	R87065  Wheel Complete L/R	R86787  Fusion Brushless System 2-in-1(1800KV)	
R86754  Drive Axle				